



HEWLETT  
PACKARD

**OPERATING AND  
SERVICE MANUAL  
EXTENDED RANGE  
DC POWER SUPPLY  
HP MODEL 6002A**

HP Part No. 06002-90001

**OPERATING AND SERVICE MANUAL FOR  
SERIALS 1636A-00101 AND ABOVE**

\* For Serials above 1636A-00101  
a change page may be included.

## **CERTIFICATION**

*Hewlett-Packard Company certifies that this product met its published specifications at time of shipment from the factory. Hewlett-Packard further certifies that its calibration measurements are traceable to the United States National Bureau of Standards, to the extent allowed by the Bureau's calibration facility, and to the calibration facilities of other International Standards Organization members.*

## **WARRANTY**

This Hewlett-Packard hardware product is warranted against defects in material and workmanship for a period of one year from date of delivery. HP software and firmware products, which are designated by HP for use with a hardware product and when properly installed on that hardware product, are warranted not to fail to execute their programming instructions due to defects in material and workmanship for a period of 90 days from date of delivery. During the warranty period, HP Company will, at its option, either repair or replace products which prove to be defective. HP does not warrant that the operation of the software, firmware, or hardware shall be uninterrupted or error free.

For warranty service, with the exception of warranty options, this product must be returned to a service facility designated by HP. Customer shall prepay shipping charges by (and shall pay all duty and taxes) for products returned to HP for warranty service. Except for products returned to Customer from another country, HP shall pay for return of products to Customer.

Warranty services outside the country of initial purchase are included in HP's product price only if Customer pays HP international prices (defined as destination local currency price, or U.S. or Geneva Export price).

If HP is unable, within a reasonable time, to repair or replace any product to a condition as warranted, the Customer shall be entitled to a refund of the purchase price upon return of the product to HP.

## **LIMITATION OF WARRANTY**

The foregoing warranty shall not apply to defects resulting from improper or inadequate maintenance by the Customer, Customer-supplied software or interfacing, unauthorized modification or misuse, operation outside of the environmental specifications for the product, or improper site preparation and maintenance. **NO OTHER WARRANTY IS EXPRESSED OR IMPLIED. HP SPECIFICALLY DISCLAIMS THE IMPLIED WARRANTIES OF MERCHANTABILITY AND FITNESS FOR A PARTICULAR PURPOSE.**

## **EXCLUSIVE REMEDIES**

**THE REMEDIES PROVIDED HEREIN ARE THE CUSTOMER'S SOLE AND EXCLUSIVE REMEDIES. HP SHALL NOT BE LIABLE FOR ANY DIRECT, INDIRECT, SPECIAL, INCIDENTAL, OR CONSEQUENTIAL DAMAGES, WHETHER BASED ON CONTRACT, TORT, OR ANY OTHER LEGAL THEORY.**

## **ASSISTANCE**

*The above statements apply only to the standard product warranty. Warranty options, extended support contracts, product maintenance agreements and customer assistance agreements are also available. Contact your nearest Hewlett-Packard Sales and Service office for further information on HP's full line of Support Programs.*

MANUAL CHANGES  
 Model 6002A Extended Range Power Supply  
 Manual HP P/N 06002-90001

5/16/89

Make all corrections in the manual according to errata below, then check the following table for your power supply serial number and enter any listed changes(s) in the manual.

SERIAL		MAKE
Prefix	Number	CHANGES
ALL	-----	ERRATA
1636A	00111-00160	1,2*,4
1642A	00161-00200	1,2,3,4
1651A	00201-00795	1,2,3
1802A	02666-02785	1-6
1938A	00786-03875	1-6
2033A	03876-04325	1-7
2049A	04326-04825	1-8
2113A	04826-05875	1-9
2113A	05876-05925	1-10
2204A	05926-08025	1-10
2348A	08026-08300	1-11,12*
2408A	08301-08350	1-12
2412A	08351-08750	1-13
2428A	08751-09000	1-14
2438A	09001-09500	1-15
2509A	09501-09700	1-16
2525A	09701-10840	1-17
2731A	10841-11590	1-18
2924A	11591-11650	1-19
2930A	11651-up	1-20

A300VR1: Change to 16.2 V zener diode.

A300R112: Change value to 30.1 k.

A300R13: Change value to 200 k.

In the second sentence of paragraph 3-75, change the reference to 0.5 V to read -0.5 V.

In the replaceable parts list, page 6-10, under Chassis Electrical, change U1,2 to HP P/N 1906-0224.

CHANGE 1:

Two resistor values have been changed to improve the supply's transient response. On page 6-6 of the parts list and in the constant voltage comparison amplifier on the Figure 7-9 schematic: Change A1R19 to 1.5 k, 5%, 3 W, HP P/N 0811-1805, and change A1R21 to 7.5 k, 1%, 1/8 W, HP P/N 0757-0440.

CHANGE 2:

\*Serial numbers 1636A-00113, 00114, 00117, 01227, 00132 and 00122 are not affected by this change.

ERRATA:

On pages A-19 through A-21 of Appendix A, make the following changes to the Option 001 Parts List.

A100J1: HP-IB connector (24-pin) microribbon, Mfr. P/N 57-20240-2, Mfr. Code 71785.

On page A-26 of the Appendix, change the A200U15 isolator circuit on Sheet 3 of the schematic (Figure A-15) as follows: Connect resistor A200R17 (4.12k) between VDD and pin 6 of isolator A200U15.

On page A-27 of the Appendix, change the range switch circuit on Sheet 4 of the schematic as follows:

A capacitor is added to eliminate activation of the turn-on/turn-off circuit in the Option 001 HP-IB circuitry due to external noise.

On page 6-9 of parts list, under Front Panel, add capacitor C2, 0.1 microfarad 500 V, HP P/N 0160-0269.

On schematic (Figure 7-9), connect C2 between + and ground front panel terminals.

ERRATA:

On schematic (Figure 7-9), change reference designation of power module capacitor from "C1" to "C2". In the replaceable parts list, page 6-8, change A1U1, U2 to IC Op Amp, HP P/N 1826-0092, and change A1U5 to IC Latch, D-Type, CMOS, HP P/N 1820-0958.

CHANGE 3:

In Option 001 instruments, four resistors have been changed in value on the A300 Analog Board Assembly. Make the following changes to the schematic on page A-27 and the parts list on pages A-20 and A-21: Model 6002A Page -2-

Change A300R12 to 13.3 k, 1%, 1/8 W, HP P/N 0757-0289, Change A300R13 to 30.1k, 1%, 1/8 W, HP P/N 0757-0453, Change A300R26 to 11.3 k, 1%, 1/8 W, HP P/N 0698- 4121. Change A300R27 to 36.5 k, 1%, HP P/N 0757-0455.

CHANGE 4:

This correction to the manual applies only to Option 001 instruments with serial numbers 1642A-00200 and earlier. In the parts list on page A-19 and on the schematic on page A-28, change capacitors A200C7-C13, and C20-C22 to 0.01 microfarad, 25 V, HP P/N 0160-2964.

ERRATA:

Under Front Panel - Mechanical on page 6-10 of the parts list, add two lamp header assemblies, HP P/N 5060-0458. These improve the mechanical stability of the green LED mode indicators.

On page 6-6, change the part number of A1R15 to 2100-1759. The resistor has not been changed; just its part number has.

ERRATA:

On Table A-4, board A200, change U21-U26 from HP P/N 1820-1540 to 1820-0958.

CHANGE 5:

On page 6-8, A2 Interconnect Board, change C4 to 15 microfarad, 75 V, HP P/N 0180-2900. On page 6-9, Front Panel Electrical, change C1 to 15 microfarad, 75 V, HP P/N 0180-2900.

ERRATA:

In Figure A-9, Overall Troubleshooting Flow Chart on page A-16, change the instruction box located on the lower rightside of the chart to read: Check that levels at Q outputs of A200U21, U22, and U23 are as follows:

Pin	Level
2	1(HI)
10	0(LO)
11	0(LO)
1	1(HI)

In Figure A-10, Digital Circuits Troubleshooting Flow Chart on page A-17, change two instruction boxes on right side of chart under "Data Storage" to read:

[First Block (Top)]

Check that levels at Q outputs of A200U21, U22, and U23 are as follows:

Pin	Level
2	1(HI)
10	0(LO)
11	0(LO)
1	1(HI)

[Second Block (Bottom)]

Check that levels at Q outputs of A200 U21, U22, and U23 are as follows:

Pin	Level
2	0(LO)
10	1(HI)
11	1(HI)
1	0(LO)

CHANGE 6:

In the replaceable parts list and on the schematic, add C34, 10pF 300 V mica, HP 0160-2197, to the A1 Control Board. C34 is connected in parallel with R70 in the +5 V Reference Supply (pin 4 to pin 13 of A1U6).

ERRATA:

On page 6-5, the Mfr. P/N and the HP P/N for J7 and J8 should be interchanged, Also, on the same page change A1CR10 to HP P/N 1901-0841. On page 6-11, the HP P/N for the Line Cord supplied in the U.S. ect. Should be 8120-1348. On page A-20 change the HP P/N of A200U15-U17 to 1990-0608, A200U21-U26 to 1820-0958. On page A-21 change the description of A300VR1 to 16.2 V. On page 7-1, the components labeled A2C4 and A2C5 should be A3C4 A3C5. On page 7-2, Figure 7-2, the component located between R93 and R18 should be labeled VR6. On page A-20 change the descriptions of A300R112 to 30.1 k and A300R13 to 200k; the HP P/N's are correct.

ERRATA (cont.)

Delete paragraph 3-47 in Manual.

In Table 1-1 specifications under REMOTE VOLTAGE CONTROL and in paragraph 3-46 change 50 mV/A +/-10% to read 50mV/A +/-10% 7.5 mV offset.

CHANGE 7:

In the replaceable parts list on page 6-7, and on the schematic change R108 to 390 ohm 2 W 5% HP P/N 0811-1764.

CHANGE 8:

In the replaceable parts list page 6-10 change S1 to HP P/N 3101-2456.

CHANGE 9:

Add resistor R117 162 ohm 1/8 W HP P/N 0757-0405 quantity 1 to the replaceable parts list and the schematic Figure 7-9. R117 is located in the overvoltage crowbar circuit, in series with potentiometer R3. In the replaceable parts list page 6-10 under Chassis Electrical, change B1 to ball bearing fan HP P/N 3160-0369.

CHANGE 10:

In the replaceable parts list, page A-21 under Mechanical, add the following parts: Cable Assembly HP P/N 8120-3691 qty. 1, Header Assembly HP P/N 1251-7820 qty. 1.

On page A-22, Figure A-12, change the A100 Input Board's pad names to their new names. Also, add four more pads with names to the board as indicated below in the New Name column.

(Prior Names)	(New Names)
*--V OUT	*--IN BOARD
*----- $\sqrt{1}$	*-----CC WIPER
*--INBOARD	*--CC PULLOUT
*-----CC WIPER	*-----(-6.2V)
*--CC INPUT	*--OUT BOARD
*-----(-6.2V)	*-----(-S)
*--OUT BOARD	*--CV WIPER
*-----(-S)	*-----CV PULLOUT
*--CV WIPER	*--(+6.2V)
*-----CV PULLOUT	*-----(-S)
*--(+6.2V)	*--V OUT
*-----(+S)	*----- $\sqrt{1}$
	/*--N.C.
4 New Pads /	*--N.C.
& Names \	*----- $\sqrt{7}$
	/*--(+5V)

CHANGE 11:

In the replaceable parts list for the A1 Control Board, page 6-5, add C38, 10uF, 20 V, HP P/N 0180-0374, Qty. 1. On page 6-8 add resistor R118, 1K, 1/8W, HP P/N 0757-0280, qty 1. On the Schematic Diagram, Figure 7-9, locate the Turn-Off Control Circuit. Disconnect R98 from the base of Q10. Connect R118 one end to the base of Q10 and the other end connect to the disconnected R98. Next connect C38 (negative) to the emitter of Q10.

CHANGE 12:

In the replaceable parts list, page A-21, delete Cable Assembly HP P/N 8120-3691 and Header Assembly HP P/N 1251-7820 previously added in change 10 and add in there place 16 conductor flat cable, HP P/N 8120-4466, qty 1. This cable connects the Input Board to the Digital Board.

\* This change also applies to units with the following prefix-serial numbers; 2348A-08251 through 2348A-08300.

ERRATA:

On page A-16, Figure A-9, near the center of the page, change the box that says "CHECK U28-13 TP TO A300 BOARD" to "CHECK TP ON A300 BOARD WHICH REFERENCE U28-13 ON A200 BOARD".

On page 5-14 paragraph 5-88, change step b. to read: Program externally using either 1000 ohm or 500mV and turn on the supply.

On the same page, paragraph 5-89, change step c. to read: Program externally using 1.25mV or 2.5 ohms and adjust A1R6 for 25mA indication. Change in step d. "Adjust A1R6 for 0+/-50Vdc" to "Adjust A1R6 for 0 +50uVdc".

ERRATA

In the specifications table 1-1, page 1-3, OVERVOLTAGE PROTECTION should read "Trip Voltage adjustable from 3.5V to 60V." Page 1-1 paragraph 1-5 second sentence should read "adjusted between 3.5 and 60V." Page 3-3, paragraph 3-5, second sentence should read "unit is from 3.5 to 60V."

ERRATA:

ERRATA (cont.)

On page 3-5, under paragraph heading Remote Programming, insert the following warning

WARNING

When the power supply is remote programmed with a voltage source, the programming voltage can appear at the output terminals when the AC input power is turned off. Do not contact the output terminals. The front panel meters will not indicate the presence of this voltage.

CHANGE 13:

In the replaceable parts list page 6-10, under A2 Interconnect Board Mechanical, change Heat dissipator TO-3 (Q1, CR11) to HP P/N 1205-0561.

CHANGE 14:

In the replaceable parts list, page 6-11, under Chassis Mechanical change cover-perforated, top/side 1/2 module to HP P/N 06002-00014.

CHANGE 15:

In the replaceable parts list, page 6-10 under Front Panel-Electrical, delete front panel, HP P/N 06002-00002, front panel trim, HP P/N 06002-00001, and retainer, push-on, HP P/N 0510-1157. In their place add, dress panel front, HP P/N 06002-00012, TQ 1, and sub panel front, HP P/N 06002-00013, TQ 1. On page 6-9, under Front Panel Electrical, delete LINE indicator light, HP P/N 1450-0566, TQ 1, and change switch DPST toggle LINE to HP P/N 3101-0402 and front panel cable assembly to HP P/N 06002-60005. On page 6-9, under A3 Input Board, change C4,5 to 12000uf 100Vdc, HP P/N 0180-3578, TQ 2.

In section III replace Figure 3-1 with the drawing below. In paragraph 3-2 change step c. to read; Set LINE switch 1 to ON position, (see illustration on front panel).

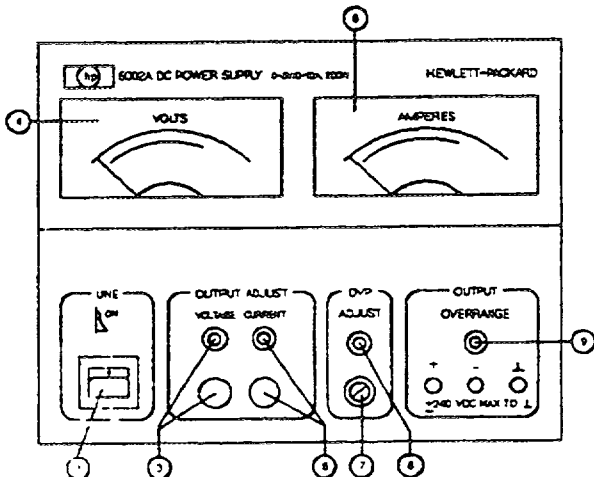

In the replaceable parts list, page 6-10, under A2 Interconnect Board, change terminal block jumpers to HP P/N 0360-2187.

CHANGE 16:

In the replaceable parts list, page 6, under Chassis Mechanical change Front frame, 1/2 module to HP P/N 5021-5817, Rear frame, 1/2 module to HP P/N 5021-5818, Corner strut, 17" to HP P/N 5021-5836, Cover-perforated, bottom 1/2 module to HP P/N 5061-9573, Front cap, strap handle to HP P/N 5041-6819 and Rear cap, strap handle to HP P/N 5041-6820.

On page 1-1 under ACCESSORIES change Two Front Handles to HP P/N 5061-9690, Lock Link to HP P/N 5061-9694, Rack Mounting Kit for one half module to HP P/N 5061-9660, Rack Mounting Kit for two half module units to HP P/N 5061-9678, Support Shelf to HP P/N 5061-9698 and Front Filler Panel to HP P/N 5061-9727.

On page 5-12 add the following CAUTION after paragraph 5-65 Repair and Replacement

CAUTION

Most of the attaching hardware in this unit is non-metric (sometimes called English or inch). The only metric fittings are listed below.

- a. Strap handle screws, Qty. 2
- b. Strap handle nut, Qty. 1
- c. Screws attaching side struts to front and rear chassis, Qty. 16

CHANGE 17:

In the replaceable parts list page 6-7 and on the schematic Figure 7-9 change resistor A1R75 to 261K 1/8 W, HP P/N 0698-3455. Also, on the schematic change the frequency of the clock (ref. A1U3) to 9Khz. On page 7-4 change the following wave forms in figure 7-8;

TP2-TP4 change 47us to 102us.

A3Q1/Q2 Base to Emitter change 45us to 100us.

A3Q1/Q2 Collector to Emitter change 47us to 102us

In the replaceable parts list, page 6, under A1 Heatsink Board (Top) and A5 Heatsink Board (Bottom) change Q1-3 to HP P/N 1854-1070.

>CHANGE 18:

In the replaceable parts list for option 001, A300 Analog Board Assembly, page A-20 delete C6,7,13 HP P/N 0150-0121, C8,9 HP P/N 0160-3068, and U3 HP P/N 1826-0140. Add the following parts to the Analog Board Assembly page A-20;

- Q8, PNP transistor HP P/N 1853-0234, TQ 1
- Q9, NPN transistor HP P/N 1854-0456, TQ 1
- R31,32, 47 ohm 1/4W, HP P/N 0683-4705, TQ2
- R33,34, 10 ohm 1/8W, HP P/N 0757-0346, TQ2
- C6,7,13 0.1uf, 50V, HP P/N 0160-4835, TQ3
- C8,9, 1800pf, HP 0160-4820, TQ 2
- U3, IC +/-15V reg. HP P/N 1826-0128, TQ 1

All parts mentioned in this change (with exception of C13) either changed or deleted are located in the +/-15V Regulated Supply Circuit on page A-23, Figure A. A300 Board. Capacitor C13 is located in the P/O +5V Reg. Supply.

On page A-28, Figure A-15 (sheet 5). Option 001, Power Distribution change the +/-15V Regulated Supply to appear as follows;

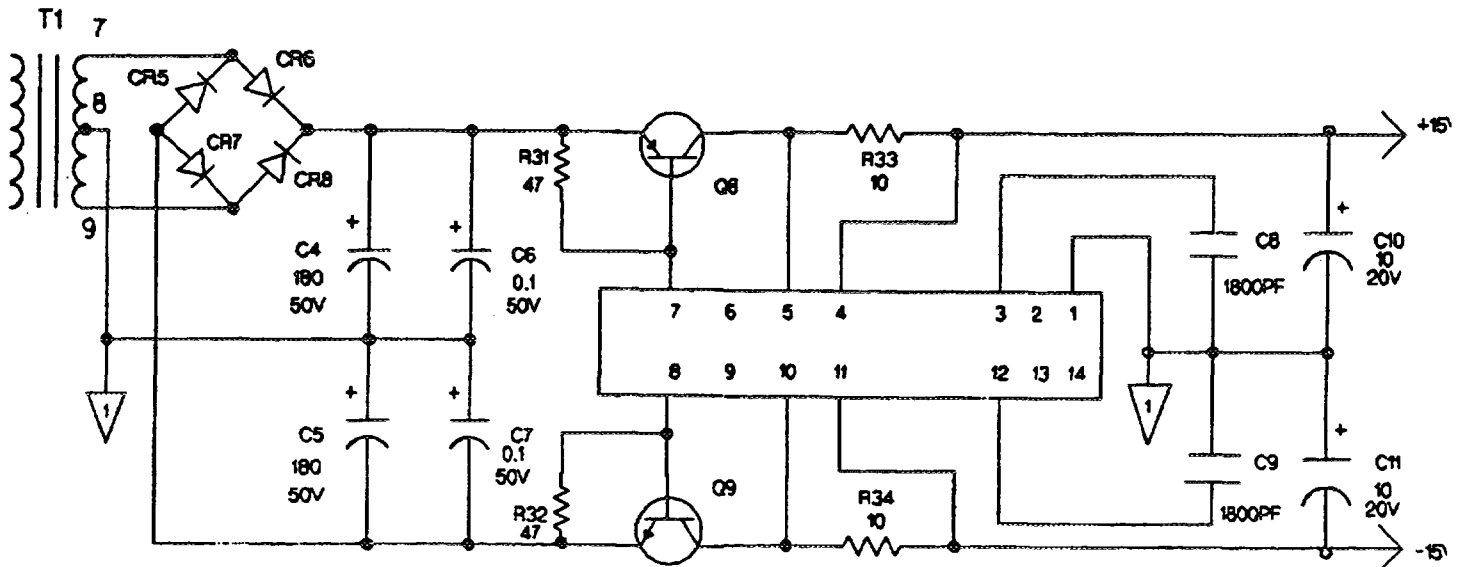

ERRATA:

In the replaceable parts list, change the part number for CR13 on the 06002-60021 assembly from HP P/N 1884-0058 to HP P/N 1884-0219.

ERRATA:

FOR OPTION 001 UNITS: Change the part number for IC Regulator from HP P/N 1826-0144 to HP P/N 1826-0122 (qty 1)

ERRATA:

Change the part number for Connector, contact - male, from HP P/N 1251-0646 to HP P/N 0360-1498. (qty 21).

ERRATA:

Change the part number for Meter Bezels from HP P/N 4040-0906 to HP P/N 4040-0297 (qty 2)

CHANGE 19:

In the replaceable parts list and on the schematic, change R3 and R4 from 0.4 ohms, 5%, 20W, Center Tapped HP P/N 0811-1817 to 0.1 ohm, 5%, 20W, HP P/N 0811-3823 (qty 2)

CHANGE 20:

In the replaceable parts list, change the following parts:

Front Panel	from HP P/N 06002-00012 to HP P/N 06002-00015 (qty 1)
Cover-Top	from HP P/N 06002-00014 to HP P/N 06002-00016 (qty 1)
Cover-Bottom	from HP P/N 5061-9573 to HP P/N 5062-3873 (qty 1)
Frame Front	from HP P/N 5021-5817 to HP P/N 5021-8417 (qty 1)
Feet	from HP P/N 5040-7201 to HP P/N 5041-8801 (qty 4)
Strap Handle Assy	from HP P/N 5060-9803 to HP P/N 5062-3703 (qty 1)
End Cap	from HP P/N 5041-6819 to HP P/N 5041-8819 (qty 1)

End Cap from HP P/N 5041-6820 to  
HP P/N 5041-8820 (qty 1)

Trim Top from HP P/N 5040-7203 to  
HP P/N 5041-8803 (qty 1)

Trim sides from HP P/N 5001-04 to  
HP P/N 5001-0540 (qty 2)

Option 800 from HP P/N 5061-0077  
(rack kit) to HP P/N 5062-3978 (qty  
1)

Option 908 from HP P/N 5061-9660  
(rack kit) to HP P/N 5062-3960 (qty  
1)



## SAFETY SUMMARY

*The following general safety precautions must be observed during all phases of operation, service, and repair of this instrument. Failure to comply with these precautions or with specific warnings elsewhere in this manual violates safety standards of design, manufacture, and intended use of the instrument. Hewlett-Packard Company assumes no liability for the customer's failure to comply with these requirements.*

### BEFORE APPLYING POWER.

Verify that the product is set to match the available line voltage and the correct fuse is installed.

### GROUND THE INSTRUMENT.

This product is a Safety Class 1 instrument (provided with a protective earth terminal). To minimize shock hazard, the instrument chassis and cabinet must be connected to an electrical ground. The instrument must be connected to the ac power supply mains through a three-conductor power cable, with the third wire firmly connected to an electrical ground (safety ground) at the power outlet. For instruments designed to be hard-wired to the ac power lines (supply mains), connect the protective earth terminal to a protective conductor before any other connection is made. Any interruption of the protective (grounding) conductor or disconnection of the protective earth terminal will cause a potential shock hazard that could result in personal injury. If the instrument is to be energized via an external autotransformer for voltage reduction, be certain that the autotransformer common terminal is connected to the neutral (earthed pole) of the ac power lines (supply mains).

### INPUT POWER MUST BE SWITCH CONNECTED.

For instruments without a built-in line switch, the input power lines must contain a switch or another adequate means for disconnecting the instrument from the ac power lines (supply mains).

### DO NOT OPERATE IN AN EXPLOSIVE ATMOSPHERE.

Do not operate the instrument in the presence of flammable gases or fumes.

### KEEP AWAY FROM LIVE CIRCUITS.

Operating personnel must not remove instrument covers. Component replacement and internal adjustments must be made by qualified service personnel. Do not replace components with power cable connected. Under certain conditions, dangerous voltages may exist even with the power cable removed. To avoid injuries, always disconnect power, discharge circuits and remove external voltage sources before touching components.

### DO NOT SERVICE OR ADJUST ALONE.

Do not attempt internal service or adjustment unless another person, capable of rendering first aid and resuscitation, is present.

*Instruments which appear damaged or defective should be made inoperative and secured against unintended operation until they can be repaired by qualified service personnel.*

### DO NOT EXCEED INPUT RATINGS.

This instrument may be equipped with a line filter to reduce electromagnetic interference and must be connected to a properly grounded receptacle to minimize electric shock hazard. Operation at line voltages or frequencies in excess of those stated on the data plate may cause leakage currents in excess of 5.0 mA peak.

### SAFETY SYMBOLS.



Instruction manual symbol: the product will be marked with this symbol when it is necessary for the user to refer to the instruction manual (refer to Table of Contents).



Indicates hazardous voltages.



or



Indicate earth (ground) terminal.

**WARNING**

The WARNING sign denotes a hazard. It calls attention to a procedure, practice, or the like, which, if not correctly performed or adhered to, could result in personal injury. Do not proceed beyond a WARNING sign until the indicated conditions are fully understood and met.

**CAUTION**

The CAUTION sign denotes a hazard. It calls attention to an operating procedure, or the like, which, if not correctly performed or adhered to, could result in damage to or destruction of part or all of the product. Do not proceed beyond a CAUTION sign until the indicated conditions are fully understood and met.

### DO NOT SUBSTITUTE PARTS OR MODIFY INSTRUMENT.

Because of the danger of introducing additional hazards, do not install substitute parts or perform any unauthorized modification to the instrument. Return the instrument to a Hewlett-Packard Sales and Service Office for service and repair to ensure that safety features are maintained.



## TABLE OF CONTENTS

Section	Page	Section	Page
<b>I</b>	<b>GENERAL INFORMATION . . . . .</b>	<b>IV</b>	<b>PRINCIPLES OF OPERATION . . . . .</b>
	1-1	(continued)	4-1
	1-1 DESCRIPTION . . . . .	4-5 Major Circuit Divisions . . . . .	4-1
	1-8 SPECIFICATIONS . . . . .	4-7 Top Selection Triacs and	
	1-10 OPTIONS . . . . .	Control Logic . . . . .	4-1
	1-12 ACCESSORIES . . . . .	4-12 Series Regulator Feedback Loop . . . . .	4-3
	1-14 INSTRUMENT AND MANUAL	4-21 Overvoltage Protection Circuit . . . . .	4-4
	IDENTIFICATION . . . . .	<b>4-23 DETAILED CIRCUIT</b>	
	1-17 ORDERING ADDITIONAL	<b>DESCRIPTION . . . . .</b>	4-4
	MANUALS . . . . .	4-25 Tap Selection Control Logic . . . . .	4-4
		4-32 Operation of Feedback Loop . . . . .	4-5
<b>II</b>	<b>INSTALLATION . . . . .</b>	4-39 Series Regulator . . . . .	4-6
	2-1 INITIAL INSPECTION . . . . .	4-42 Driver, Error, and Mixer	
	2-3 Mechanical Check . . . . .	Amplifiers . . . . .	4-6
	2-5 Electrical Check . . . . .	4-45 Constant-Voltage Comparison	
	2-7 REPACKAGING FOR	Amplifier . . . . .	4-6
	SHIPMENT . . . . .	4-50 Constant-Current Comparison	
	2-9 INSTALLATION DATA . . . . .	Amplifier . . . . .	4-7
	2-11 Location and Cooling . . . . .	4-54 Operating Mode Indicator	
	2-13 Outline Diagram . . . . .	Circuit . . . . .	4-7
	2-15 Rack Mounting . . . . .	4-58 Overvoltage Crowbar Circuit . . . . .	4-7
	2-17 Input Power Requirements and	4-63 Reference Supplies . . . . .	4-8
	Line Voltage Conversion . . . . .	4-67 Meter Circuit . . . . .	4-8
	2-21 Power Cable . . . . .	4-71 Special Purpose Components . . . . .	4-8
<b>III</b>	<b>OPERATING INSTRUCTIONS . . . . .</b>	<b>V</b>	<b>MAINTENANCE . . . . .</b>
	3-1 TURN-ON CHECKOUT	5-1 INTRODUCTION . . . . .	5-1
	PROCEDURE . . . . .	5-3 TEST EQUIPMENT REQUIRED . . . . .	5-1
	3-3 OPERATING MODES . . . . .	5-5 PERFORMANCE TEST . . . . .	5-2
	3-5 NORMAL OPERATING MODE . . . . .	5-7 Measurement Techniques . . . . .	5-2
	3-10 Constant Voltage Operation . . . . .	5-11 Constant-Voltage Tests . . . . .	5-2
	3-12 Constant Current Operation . . . . .	<b>5-42 CONSTANT-CURRENT TESTS . . . . .</b>	5-6
	3-14 Overvoltage Protection . . . . .	<b>5-53 TROUBLESHOOTING . . . . .</b>	5-8
	3-20 CONNECTING THE LOAD . . . . .	5-58 Initial Troubleshooting	
	3-25 OPTIONAL OPERATING	Procedures . . . . .	5-8
	MODES . . . . .	5-63 Overall Trouble Isolation . . . . .	5-9
	3-27 Remote Voltage Sensing . . . . .	<b>5-65 REPAIR AND REPLACEMENT . . . . .</b>	5-12
	3-32 Remote Programming . . . . .	5-66 Outside Cover Removal . . . . .	5-12
	3-48 Auto-Parallel Operation . . . . .	5-69 A1 Control Board Removal . . . . .	5-12
	3-55 Auto-Series Operation . . . . .	5-71 Front Panel Removal . . . . .	5-12
	3-65 Auto-Tracking Operation . . . . .	5-73 Top and Bottom Heat Sink	
		Removal . . . . .	5-12
<b>IV</b>	<b>PRINCIPLES OF OPERATION . . . . .</b>	5-75 Replacement Parts . . . . .	5-13
	4-1 DIFFERENCE BETWEEN	<b>5-77 ADJUSTMENT AND</b>	
	STANDARD LAB SUPPLY	<b>CALIBRATION . . . . .</b>	5-13
	AND EXTENDED RANGE	5-79 Meter Zero Adjustment . . . . .	5-13
	SUPPLY . . . . .	5-81 Voltmeter Calibration . . . . .	5-13
	4-3 OVERALL DESCRIPTION . . . . .		

## TABLE OF CONTENTS (Continued)

Section		Page	Section		Page
<b>V</b>	<b>MAINTENANCE</b>		<b>APPENDIX A</b>		
(continued)			<b>HP-IB OPTION 001</b>		
5-83	Ammeter Calibration . . . . .	5-13	<b>A-1 GENERAL INFORMATION . . . . .</b>	<b>A-1</b>	
5-85	Constant-Voltage Programming		<b>A-13 INSTALLATION DATA . . . . .</b>	<b>A-3</b>	
	Accuracy . . . . .	5-14	<b>A-24 PROGRAMMING . . . . .</b>	<b>A-5</b>	
5-87	Constant-Current Programming		<b>A-43 OPERATING INSTRUCTIONS . . . . .</b>	<b>A-8</b>	
	Accuracy . . . . .	5-14	<b>A-55 CIRCUIT DESCRIPTION . . . . .</b>	<b>A-9</b>	
5-90	+5V Reference Voltage		<b>A-85 MAINTENANCE . . . . .</b>	<b>A-13</b>	
	Adjustment . . . . .	5-14	<b>A-109 DIAGRAMS . . . . .</b>	<b>A-18</b>	
5-92	Calibration of Output Current		Replaceable Parts . . . . .	<b>A-19</b>	
	Decision Points . . . . .	5-14			
<b>VI</b>	<b>REPLACEABLE PARTS . . . . .</b>	<b>6-1</b>	<b>VII</b>	<b>CIRCUIT DIAGRAMS AND</b>	
				<b>COMPONENT LOCATION</b>	
				<b>DIAGRAMS . . . . .</b>	<b>7-1</b>

## SECTION I GENERAL INFORMATION

### 1-1 DESCRIPTION

1-2 This laboratory type power supply employs a unique extended range technique which allows the supply to furnish maximum output power over a wide range of output voltage and current combinations. The supply can provide a full 200 Watts of output from 20V, 10A to 50V, 4A. The output is completely adjustable through the entire operating range of 0 to 50 volts and 0 to 10 amps by front panel voltage and current controls.

1-3 The supply is of the Constant Voltage/Constant Current (CV/CC) type and provides laboratory grade performance. It is fan cooled and packaged in a System II modular enclosure which is sturdy, attractive, and easily accessible for servicing.

1-4 Output voltage and current are continuously indicated on individual front panel meters. Four LED indicators on the front panel provide a convenient means of monitoring the operating status of the supply. They inform the user whether the supply is in the constant voltage or constant current mode; or whether the supply is in an overrange (operating beyond the 200 Watt boundaries) or overvoltage protection condition.

1-5 The overvoltage protection crowbar circuit protects the users load by quickly and automatically shorting the output terminals if a preset trip voltage is exceeded. A screwdriver control on the front panel sets the overvoltage trip point and can be adjusted between 2.5V and 60V. If several of these supplies are installed in the same system their crowbar circuits can be "slaved" together so that all supplies will crowbar if any one of them does.

1-6 Either the positive or negative output terminal of the supply may be grounded or the output may be floated at up to 150 volts above ground.

1-7 Remote programming, remote sensing, and several methods of operating supplies in combination of two or three are made possible by rear panel terminals that allow access to control points within the regulator circuits. These capabilities are described in Section III.

### 1-8 SPECIFICATIONS

1-9 Detailed specifications for this power supply are given in Table 1-1.

### 1-10 OPTIONS

1-11 Options are factory modifications of a standard instrument that are requested by the customer. One Option is available for this instrument as indicated below. Detailed coverage of this Option is presented in Appendix A.

<u>OPTION NO.</u>	<u>DESCRIPTION</u>
001	HP-IB Interface: Allows the supply to be digitally controlled via the HP-IB from a calculator, computer, or other controller. This modification involves the changing of internal PC board jumpers and the addition of three PC boards, two switches and an HP-IB connector. Either the output voltage or current can be programmed by the HP-IB controller

### 1-12 ACCESSORIES

1-13 The System-II cabinet accessories listed below may be ordered with the power supply or separately from your local Hewlett-Packard field sales office (refer to list at rear of manual for addresses). All accessories applicable to System-II modular cabinets are fully described and illustrated in the Hewlett-Packard catalog.

<u>HP Part No.</u>	<u>Description</u>
5061-0090	Two front handles that attach to each side of 7" high cabinets.
5061-0094	Kit of lock link hardware for joining together cabinets of equal depth. Units can be joined side-by-side or vertically. This kit is required whenever two (or more) sub-module units are to be rack mounted side-by-side.
1460-1345	Tilt stand snaps into standard foot supplied with instrument — must be used in pairs.
5061-0060	Rack mounting kit for one half module width unit, 7-inches high. Includes one rack flange (ear) and one half module width extension panel (adapter).
5061-0078	Rack mounting kit for two half module units,

7" high. Kit includes two rack flanges (ears). Also, lock-together kit (5061-0094) is required for joining the two supplies together. The cabinets must also be of equal depth (17").

5061-0055 Rack mounting kit for two units (one half module width and one quarter module width). Kit includes one rack flange and one quarter width extension adapter. Lock-together kit (5061-0094) is required for joining the two supplies.

5061-0098 Support shelf for mounting one or more 7" high units which are half module or quarter module width. Cabinet depths need not be equal.

5061-2027 Front filler panel (half module width) for 7" high support shelf.

1494-0015 Slide kit for support shelves mounted in HP rack enclosures.

## 1-14 INSTRUMENT AND MANUAL IDENTIFICATION

1-15 Hewlett-Packard power supplies are identified by a two part serial number. The first part is the serial number prefix, a number-letter combination that denotes the date of a significant design change and the country of manufacture. The first two digits indicate the year (10 = 1970, 11 = 1971, etc.), the second two digits indicate the week, and the letter "A" designates the U. S. A. as the country of manufacture. The second part is the power supply serial number; a different sequential number is assigned to each power supply, starting with 00101.

1-16 If the serial number on your instrument does not agree with those on the title page of the manual, Change Sheets supplied with the manual of Manual Backdating Changes define the difference between your instrument and the instrument described by this manual.

## 1-17 ORDERING ADDITIONAL MANUALS

1-18 One manual is shipped with each power supply. Additional manuals may be purchased from your local Hewlett-Packard field office (see the list at the rear of this manual for addresses). Specify the model number, serial number prefix, and the HP Part Number provided on the title page.

Table 1-1. Specifications, Model 6002A

<p><b>INPUT POWER:</b> Unit has ac power module which is settable to: 100/120/220/240Vac (-13%, +6%), 48-63Hz. A 3-wire detachable line cord is supplied.</p> <p><b>DC OUTPUT:</b> Adjustable from 0-50V and 0-10A. Maximum output power is 200W from 20-50V.</p> <p><b>LOAD EFFECT (LOAD REGULATION):</b> <u>Constant Voltage</u> — Less than 0.01% of output plus 1mV for a load change equal to the maximum current rating of the supply. <u>Constant Current</u> — Less than 0.01% of output plus 1mA for a load change equal to the maximum voltage rating of the supply.</p> <p><b>SOURCE EFFECT (LINE REGULATION):</b> <u>Constant Voltage</u> — Less than 0.01% of output plus 1mV for any line voltage change within rating. <u>Constant Current</u> — Less than 0.01% of output plus 1mA for any line voltage change within rating.</p> <p><b>PARD (Ripple and Noise):</b> <u>Constant Voltage</u> — Less than 1mV rms and 10mV p-p (20Hz to 20MHz). <u>Constant Current</u> — Less than 5mA rms.</p>	<p><b>TEMPERATURE COEFFICIENT:</b> <u>Constant Voltage</u> — Less than 0.02% plus 200<math>\mu</math>V change in output per degree Celsius change in ambient following a 30-minute warmup. <u>Constant Current</u> — Less than 0.02% plus 5mA change in output per degree Celsius change in ambient following a 30-minute warmup.</p> <p><b>DRIFT (STABILITY):</b> (Change in output over an 8-hour interval under constant line, load, and ambient temperature following a 30-minute warmup). <u>Constant Voltage</u> — Less than 0.05% of output plus 1mV. <u>Constant Current</u> — Less than 0.05% of output plus 5mA.</p> <p><b>LOAD TRANSIENT RECOVERY TIME:</b> Less than 100<math>\mu</math>sec is required for output voltage recovery (in constant voltage operation) to within 15mV of the nominal output following a change in output current from 50% to 100% or 100% to 50% of maximum current rating.</p> <p><b>REMOTE RESISTANCE CONTROL:</b> CV: 1K<math>\Omega</math>/V <math>\pm</math>7% CC: 100<math>\Omega</math>/A <math>\pm</math>7%</p> <p><b>REMOTE VOLTAGE CONTROL:</b> CV: 1V/V <math>\pm</math>20mV (-50mV offset) CC: 50mV/A <math>\pm</math>10%</p>
---	--

Table 1-1. Specifications, Model 6002A (continued)

<p><b>RESPONSE TIME:</b> Maximum time for output voltage to change between 0 to 99.9% or 100% to 0.1% of maximum rated output voltage.</p> <p>UP: No Load – 100msec Full Load – 100msec</p> <p>DOWN: No Load – 400msec Full Load – 200msec</p> <p><b>OVERVOLTAGE PROTECTION:</b> Trip voltage adjustable from 2.5V to 60V. Minimum setting above output voltage to avoid false tripping is 1 volt.</p> <p><b>DC OUTPUT ISOLATION:</b> 150Vdc</p> <p><b>TEMPERATURE RATINGS:</b> Operating: 0 to 55°C    Storage: -40 to +75°C</p>	<p><b>RESOLUTION:</b> (Minimum output voltage or current change that can be obtained using the front panel controls.) CV: 10mV    CC: 10mA</p> <p><b>OUTPUT IMPEDANCE:</b> Typical value is 0.5m<math>\Omega</math> in series with 1<math>\mu</math>H.</p> <p><b>OPTIONS:</b> 001 HP-IB Interface – specifications listed in Appendix A.</p> <p><b>DIMENSIONS:</b> (See Figure 2-1)</p> <p><b>WEIGHT:</b> Net: 14.5kg. (32 lb) Shipping: 15.9kg. (35 lb)</p>
---	--





## SECTION II INSTALLATION

### 2-1 INITIAL INSPECTION

2-2 Before shipment, this instrument was inspected and found to be free of mechanical and electrical defects. As soon as the instrument is unpacked, inspect for any damage that may have occurred in transit. Save all packing materials until the inspection is completed. If damage is found, file claim with carrier immediately. The Hewlett-Packard Sales and Service office should be notified as soon as possible.

### 2-3 Mechanical Check

2-4 This check should confirm that there are no broken knobs or connectors, that the cabinet and panel surfaces are free of dents and scratches, and that the meters are not scratched or cracked.

### 2-5 Electrical Check

2-6 Section V of this manual contains complete verification procedures for this unit. Section III contains an abbreviated check which can be used to quickly place the unit into operation. Refer to the inside front cover of the manual for the Certification and Warranty statements.

### 2-7 REPACKAGING FOR SHIPMENT

2-8 To insure safe shipment of the instrument, it is recommended that the package designed for the instrument be used. The original packaging material is reusable. If it is not available, contact your local Hewlett-Packard field office to obtain the materials. This office will also furnish the address of the nearest service office to which the instrument can be shipped. Be sure to attach a tag to the instrument specifying the owner, model number, full serial number, and service required, or a brief description of the trouble.

### 2-9 INSTALLATION DATA

2-10 The instrument is shipped ready for bench operation. Before applying power to the instrument, read paragraph 2-18.

### 2-11 Location and Cooling

2-12 This instrument is fan cooled and must be installed

with sufficient space for cooling air flow between the sides and rear of the unit. It should be used in an area where the ambient temperature does not exceed 55°C.

### 2-13 Outline Diagram

2-14 Figure 2-1 illustrates the outline shape and dimensions of this cabinet.

### 2-15 Rack Mounting

2-16 This supply can be rack mounted in a standard 19-inch rack panel either by itself or alongside another half (or quarter) System-II module of equal height and depth. All rack mounting accessories for this unit are listed in paragraph 1-12. Also, complete installation instructions are included with each rack mounting kit.

### 2-17 Input Power Requirements and Line Voltage Conversion

2-18 This supply may be operated continuously from a nominal 100V, 120V, 220V, or 240V (48-63Hz) power source. A printed circuit board located within the ac power module on the rear panel must be positioned to match the

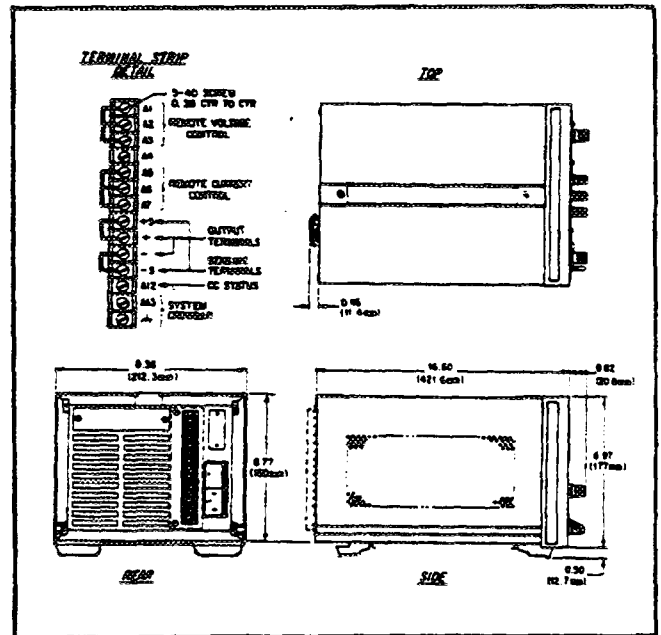

Figure 2-1. Outline Diagram

power source. Voltage choices are available on both sides of the PC board. Before connecting the instrument to the power source, check that the PC board position matches the nominal line voltage of the source. The operating voltage that is selected is the one printed on the lower-left side of the PC board. As shipped from the factory, the PC board in this supply is positioned for 120Vac operation.

To select another input voltage proceed as follows:

- a. Remove power cable from instrument.
- b. Slide down plastic door on power module.
- c. Push FUSE PULL down and remove line fuse

F1 (Figure 2-2).

d. Remove PC board from slot by inserting pointed object into hole in PC board and gently pulling outward. Select operating voltage by orienting PC board to position the desired voltage on lower-left side of PC board. Push board firmly back into slot.

e. Push FUSE PULL up into normal position and re-insert fuse F1 in holder using caution to select the correct value for F1 (6A for 100V or 120V and 4A for 220V or 240V).

- f. Close plastic door and connect power cable.

2-19 When the instrument leaves the factory, the 6A fuse is installed for 120V operation. An envelope containing a 4A fuse for 220V/240V operation is attached to the instrument. Make sure that the correct fuse value for F1 is installed if the position of the PC board is changed.

2-20 The input voltage range and input current required for each of the four nominal input voltages associated with this unit are listed below. The maximum input power required for any of the four inputs is 480 Watts.

<u>Nominal Input Voltage</u>	<u>Maximum Input Range</u>	<u>Maximum Input Current</u>
100Vac	87-106Vac	6.6A
120Vac	104-127Vac	5.6A
220Vac	191-233Vac	3.0A
240Vac	208-250Vac	2.8A

## 2-21 Power Cable

2-22 This unit is factory equipped with a power cord plug that is the most appropriate for the user's location. The replaceable parts section of this manual lists all of the power cords associated with this unit. If a different power cord is desired, contact your nearest HP Sales Office.

2-23 To protect operating personnel, the National Electrical Manufacturers Association (NEMA) recommends that the instrument panel and cabinet be grounded. This instrument is equipped with a three conductor power cable. The third conductor is the ground conductor and when the cable is plugged into an appropriate receptacle, the instrument is grounded. The offset pin on the power cable three-prong connector is the ground connection. In no event shall this instrument be operated without an adequate cabinet ground connection.

2-24 To preserve the protection feature when operating the instrument from a two-contact outlet, use a three-prong to two-prong adapter (if permitted by local regulations) and connect the green lead on the adapter to ground.

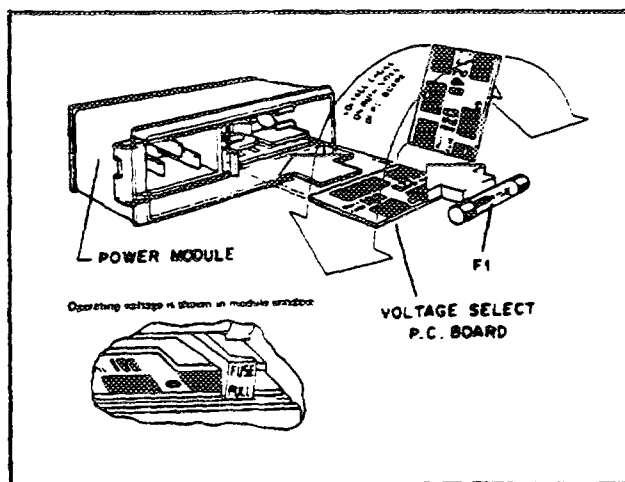

Figure 2-2. Line Voltage Conversion

## SECTION III OPERATING INSTRUCTIONS

### 3-1 TURN-ON CHECKOUT PROCEDURE

3-2 The following checkout procedure describes the use of the front panel controls and indicators (see Figure 3-1) and ensures that the supply is operational. Either this check or the detailed performance tests of paragraph 5-5 should be performed when the unit is first received. If the supply fails to perform properly, proceed to the troubleshooting procedures in Section V.

- a. Ensure that rear terminal board straps are connected as shown in Figure 3-2, but do not connect load. Ensure that ac power module board matches line voltage to be used as outlined in Section II. If unit is equipped with HP-IB interface (Option 001) ensure that rear panel switch is set to LOCAL before proceeding.
- b. Ensure that CURRENT control (5) is rotated clockwise at least two turns and OVERVOLTAGE potentiometer (7) is fully clockwise.
- c. Set LINE switch (1) to ON and observe that pilot lamp (2) lights and fan goes on.
- d. Turn VOLTAGE control (3) through output voltage span of unit as indicated on voltmeter (4). VOLTAGE MODE light (3) should be lit throughout procedure indicating that supply is in constant voltage mode.
- e. Check out overvoltage circuit by turning OVER-

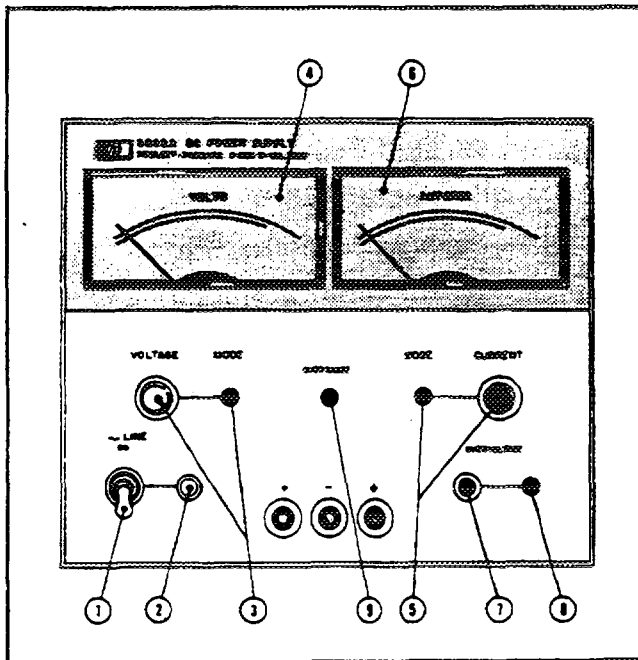

Figure 3-1. Front Panel Controls and Indicators

VOLTAGE control (7) (screwdriver adjust) counter-clockwise until unit crowbars. Voltage should drop to near zero and OVERVOLTAGE (8) and OVERRANGE (9) indicators should light.

- f. Reset crowbar circuit by returning OVERVOLTAGE control to maximum clockwise position and turning supply off and then back on. Output voltage should return to value set in step d.
- g. To check constant current circuit, first turn off supply and connect short across + and - output terminals (front or rear). Ensure that VOLTAGE control is rotated at least two turns clockwise.
- h. Next, turn supply back on and rotate CURRENT control (5) through output current span as indicated on ammeter (6). CURRENT MODE light (5) should be on throughout this procedure.
- i. Turn off supply, remove short from output, and read remainder of operating instructions before connecting actual load to supply.

### 3-3 OPERATING MODES

3-4 This power supply is designed so that its mode of operation can be selected by making strapping connections between terminals on its rear panel. The following paragraphs first describe normal operation using the normal strapping pattern as it is connected at the factory. Later paragraphs cover some optional operating modes including

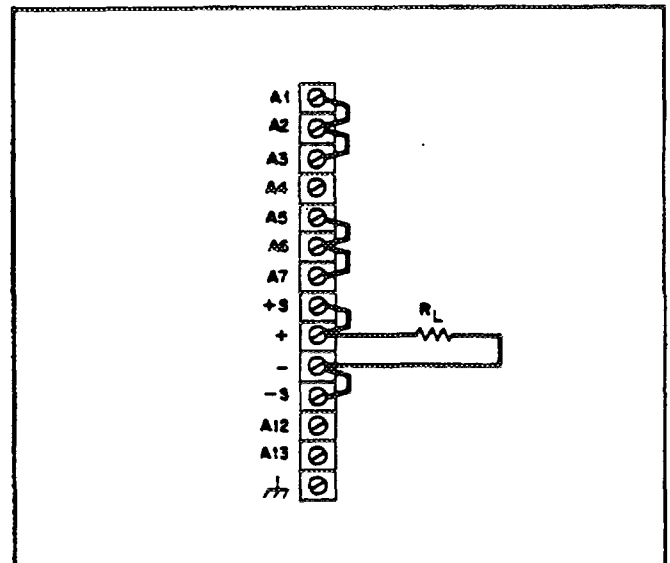

Figure 3-2. Normal Strapping

methods of operating these power supplies in combinations of two or three. More theoretical descriptions regarding the operational features of power supplies in general are given in the *DC Power Supply Handbook*, Application Note 90A (available at no charge from your local HP Sales Office).

### 3-5 NORMAL OPERATING MODE

3-6 This power supply was shipped with the proper rear panel strapping connections made for constant-voltage/constant-current operation with local sensing and local programming. This strapping pattern is illustrated in Figure 3-2. By means of the front panel voltage and current controls, the operator selects either a constant-voltage or a constant-current output as described later, in paragraphs 3-10 or 3-12. Whether the supply functions in the constant-voltage or constant-current mode depends on the settings of the VOLTAGE and CURRENT controls and on the value of the load resistance. Figure 3-3 shows the overall characteristic of this supply together with the sample operating locus that is established with voltage and current settings of 40V and 5A respectively. For values of load resistance greater than the sample crossover value of 8 ohms, the supply operates in the constant-voltage mode. With a load resistance smaller than the crossover value, it operates in the constant-current mode. The transition occurs automatically; no switches need to be operated or connections changed. The front panel MODE lights indicate which mode the supply is in. A rectangular operating locus similar to that shown in Figure 3-3 will be established for all voltage and current settings within the 200 Watt output boundaries. However, if the operator sets the voltage or current controls so that the 200 Watt limit can be exceeded, the supply will go into overrange if the load resistance exceeds the 200 Watt value (refer to next paragraph).

3-7 **Overrange.** This supply will be driven into overrange (shaded area of Figure 3-3) if the voltage and current controls are set above the 200W rating and the load resistance exceeds a 200W critical value. For example, assume that the operator sets the VOLTAGE control at 40V and the CURRENT control to 10A (Figure 3-3). For all load resistances above 8 ohms (which is the 200 Watt critical value) the supply would operate normally in the constant voltage mode. If the load resistance were to fall much below 8 ohms, however, the supply would be forced into overrange. If the load resistance continued to decrease to a 2 ohm value, the supply would automatically come out of overrange and into the constant current mode at the 10A, 20V point. (The supply will probably go out of regulation while operating in the overrange region, refer to paragraph 3-9).

3-8 The **OVERRANGE** indicator on the front panel

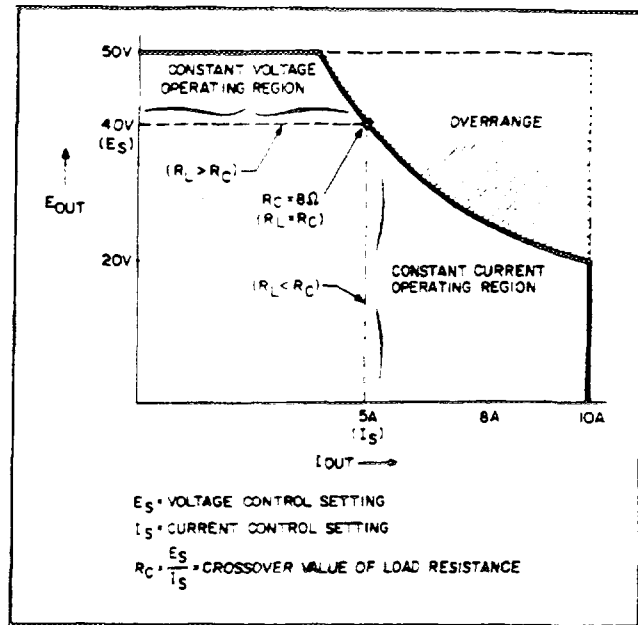

Figure 3-3. Overall Output Characteristic With Sample Operating Locus

will light any time that the supply overranges. This indicator also lights if the overvoltage crowbar fires even though the output is reduced to near zero at this time.

3-9 Note that the supply can operate in the overrange region (beyond the 200 Watt limits) for sustained periods without being damaged. However, the supply is not guaranteed to meet specifications in overrange. Output ripple increases substantially and regulation is seriously degraded. As an operator aid, the maximum available load current for each constant voltage setting is indicated on a secondary scale of the voltmeter. Similarly, the maximum available load voltage for each current setting is indicated on the ammeter.

### NOTE

*Under certain conditions of line and load, it is possible for this supply to provide more than the 200 Watt rating and still maintain regulation. If this occurs, the unit will operate normally and the **OVERRANGE** indicator will be off. However, the slightest change in either one of the above factors may cause the unit to go out of regulation and it is definitely not recommended to intentionally attempt operation beyond the 200 Watt rating of the unit.*

### 3-10 Constant Voltage Operation

3-11 To adjust the supply for constant voltage operation:  
a. Turn on supply and, with output terminals open,

adjust the VOLTAGE control for the desired output voltage. Then turn power off.

b. Connect a short across the front or rear panel output terminals, restore power, and adjust the CURRENT control for the desired maximum output current. Then remove the short. If a load change causes this current limit to be exceeded, the supply automatically crosses over to constant current operation at this preset current limit and the output voltage drops proportionately. In setting the current limit, make an adequate allowance for high peak currents that could cause unwanted crossover.

### 3-12 Constant Current Operation

3-13 To adjust the supply for constant current operation:

a. Connect a short across the front or rear output terminals, turn the power on, and adjust the CURRENT control for the desired output current.

b. Open the output terminals and adjust the VOLTAGE control for the desired maximum output voltage. If a load change causes this voltage limit to be exceeded, the supply automatically crosses over to constant voltage operation at this preset voltage limit and the output current drops proportionately. In setting the voltage limit, make an adequate allowance for high peak voltages that could cause unwanted crossover.

### 3-14 Overvoltage Protection

3-15 **Adjustment.** The crowbar trip voltage is adjusted by using the screwdriver control on the front panel. The approximate trip voltage range for this unit is from 2.5V to 60V. When the crowbar trips, an SCR shorts the output and the OVERVOLTAGE indicator on the front panel lights. Rotating the control clockwise sets the trip voltage higher. (It is set to maximum at the factory.)

3-16 When adjusting the crowbar trip point, the possibility of false tripping must be considered. If the trip voltage is set too close to the supply's operating voltage, a transient in the output would falsely trip the crowbar. For this reason it is recommended that the crowbar be set higher than the output voltage by at least one volt. To adjust the crowbar trip voltage, proceed as follows:

- a. With OVERVOLTAGE potentiometer fully CW, turn on supply; no load connected.
- b. Set output VOLTAGE control to desired trip voltage.
- c. Turn OVERVOLTAGE pot CCW until crowbar fires; red indicator lights and voltage falls to zero.
- d. Turn off supply and turn down output voltage.
- e. Turn supply back on and set desired output voltage.

3-17 **Resetting the Crowbar.** If the crowbar trips during

normal operation, the ac LINE switch must be turned off and then back on to reset the circuit. If the crowbar trips continuously check the load and/or the trip point setting. If the supply does not operate properly after the crowbar is reset, proceed to troubleshooting in Section V.

3-18 **System Crowbar Connections.** The crowbar circuit contains an extra winding which is connected across terminals A13 and  $\bar{A}$  on the rear terminal board. These terminals provide a pulse output if the overvoltage circuit trips or; conversely, can receive an external input pulse which can be used to trip the circuit. The correct polarity must be observed in the external circuit with the A13 terminal being positive. If the terminals will be used for input tripping, the external pulse must have the following characteristics:

Input trip pulse:

Amplitude: 5 – 10 Volts

Width: 2 – 5 $\mu$ sec

Source Impedance: 2 $\Omega$  (maximum)

If the terminals are used to provide an output pulse for a status indication, the output pulse has the following characteristics:

Output pulse:

Amplitude: 4 – 12 Volts

Width: 2 – 7 $\mu$ sec

Load Impedance: 10 $\Omega$  (minimum)

3-19 Because one of the system crowbar terminals is tied to chassis ground, the user should take precautions against circulating ground currents which could cause false tripping of the crowbar or make external tripping difficult. To help avoid ground loop problems, always run a separate ground terminal wire between the supply and the external source and maintain the above impedances.

### 3-20 CONNECTING THE LOAD

3-21 To satisfy the requirements of safety, the wires to the load should be at least heavy enough not to overheat while carrying the power supply current that would flow if the load were shorted. Generally, heavier wire than this is required to obtain good regulation at the load. If the load regulation is critical, use remote voltage sensing. (Refer to paragraph 3-27.)

3-22 If multiple loads are connected to one supply, each load should be connected to the supply's output terminals using separate pairs of connecting wires. This minimizes mutual coupling effects between loads and takes full advantage of the supply's low output impedance. Each pair of connecting wires should be as short as possible and twisted or shielded to reduce noise pickup.

3-23 If load considerations require the use of output distribution terminals that are located remotely from the

supply, then the power supply output terminals should be connected to the remote distribution terminals by a pair of twisted or shielded wires and each load should be separately connected to the remote distribution terminals. Remote voltage sensing would be required under these circumstances (paragraph 3-27).

3-24 Either positive or negative voltages can be obtained from this supply by grounding one of the output terminals or one end of the load. Always use two wires to connect the load to the supply regardless of where or how the system is grounded. Never ground the system at more than one point. This supply can be operated up to 150 volts above ground if neither output terminal is grounded.

### 3-25 OPTIONAL OPERATING MODES

3-26 The optional operating modes discussed in the following paragraphs include: remote voltage sensing, remote programming, auto-parallel operation, auto-series operation, and auto-tracking operation. By changing its rear panel strapping pattern according to the instructions which follow, any of the supplies covered by this manual can be operated in any of the modes listed above.

#### CAUTION

*Disconnect input ac power before changing any rear panel connections and make certain all wires and straps are properly connected and terminal strip screws are securely tightened before reapplying power.*

### 3-27 Remote Voltage Sensing

3-28 Because of the unavoidable voltage drop developed in the load leads, the normal strapping pattern shown in Figure 3-2 will not provide the best possible voltage regulation at the load. The remote sensing connections shown in Figure 3-4 improve the voltage regulation at the load by monitoring the voltage there instead of at the supply's output terminals. (The advantages of remote sensing apply only during constant voltage operation.) The following paragraphs discuss some precautions that should be observed when making a remote sensing installation.

3-29 The load leads should be of the heaviest practicable wire gauge, at least heavy enough to limit the voltage drop in each lead to 0.5 volt. This limitation is mainly dictated by the protection diode connected between the -S and - output terminal. This diode will conduct if it is forward biased by more than 0.5 volts. Note that the transient recovery time of the supply may be slower than the specified value of 100 $\mu$ sec if remote sensing is used. If this is a factor in your application, check the transient recovery time (see Section V) using the actual lead lengths that will be used in

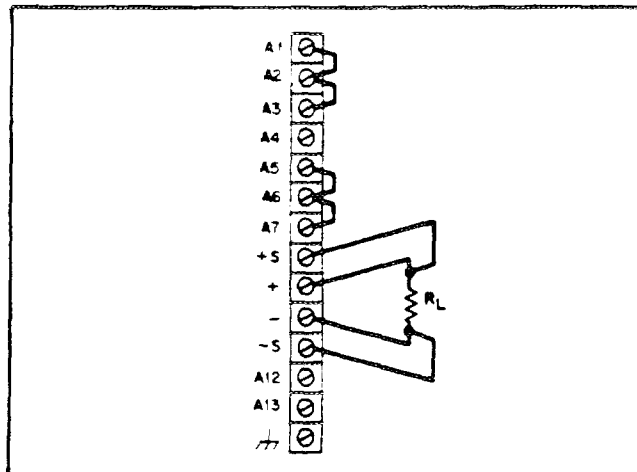

Figure 3-4. Remote Sensing

your setup. The inductance of long load leads is not a problem in this supply because it contains an internal compensating network, A2C2-R2.

#### NOTE

*Due to the voltage drop in the load leads, it may be necessary to readjust the overvoltage trip point in the remote sensing mode.*

3-30 Since the sensing leads carry only a few milliamps, the wires used for sensing can be much lighter than the load leads (22 AWG is generally adequate), but they should be a shielded, twisted pair to minimize the pickup of external noise. Any noise picked up on the sensing leads will appear at the supply's output. The shield should be grounded at one end only and should not be used as one of the sensing conductors. The sensing leads should be connected as close to the load as possible.

3-31 The sensing leads are part of the supply's programming circuit, so they should be connected in such a way as to make it unlikely that they might inadvertently become open circuited. If the sensing leads open during operation, the output voltage will tend to fall. Although the decay may be limited by protection diodes A2CR9-CR10, it is recommended that no switch, relay, or connector contacts be included in the remote sensing path.

#### CAUTION

*When using remote voltage sensing, it is possible to damage the supply by disconnecting a load lead while the sensing lead is still connected and the supply is energized. If a load lead becomes disconnected, current flows through internal protection diodes CR9 and CR10, the sensing leads, and the load and may burn out the diodes or connecting track on the PC board.*

### 3-32 Remote Programming

3-33 The output voltage or current of this supply can be remotely controlled by analog or digital means. Analog control consists of programming the output by means of an external resistor or voltage source connected to the rear terminals and is the only remote programming method that will be described in this section. Digital control of the output on the Hewlett-Packard Interface Bus (HP-IB, Option 001) is described in Appendix "A" of this manual.

3-34 For resistance programming, a variable resistor can control the output over its entire range. Or, a variable resistor connected in series with a fixed resistor can have its control restricted to a limited portion of the output range. Alternately, a switch can be used to select fixed values of programming resistance to obtain a set of discrete voltages or currents. (The switch must have make-before-break contacts to avoid producing the output voltage transients that momentarily opening the programming terminals would cause.) To maintain the temperature and stability specifications of the supply, programming resistors must be stable, low noise resistors with a temperature coefficient of less than 30ppm per °C and a power rating at least 30 times what they will actually dissipate.

3-35 Both voltage and current outputs can also be controlled by a voltage source. When voltage programming the output voltage, the choice can be made between using a connection that produces a unity gain relationship between input and output or another connection that produces variable voltage gains. The output current can be programmed using a connection that produces a fixed gain.

3-36 Connecting a supply for remote voltage or current programming disables the corresponding front panel controls.

3-37 The following paragraphs discuss in greater detail the methods of remotely programming the output voltage or current using either a resistance or a voltage input. Whichever method is used, the wires connecting the programming terminals of the supply to the remote programming device must be shielded to reduce noise pickup. The outer shield of the cable should not be used as a conductor but should be connected to ground at one end only.

3-38 Although the following connection drawings (Figures 3-5 through 3-7) show the supply strapped for local sensing, it is possible to operate the supply simultaneously in the remote sense and remote constant voltage programming modes.

3-39 **Constant Voltage Output, Resistance Control.** The rear panel connections shown in Figure 3-5 allow the output

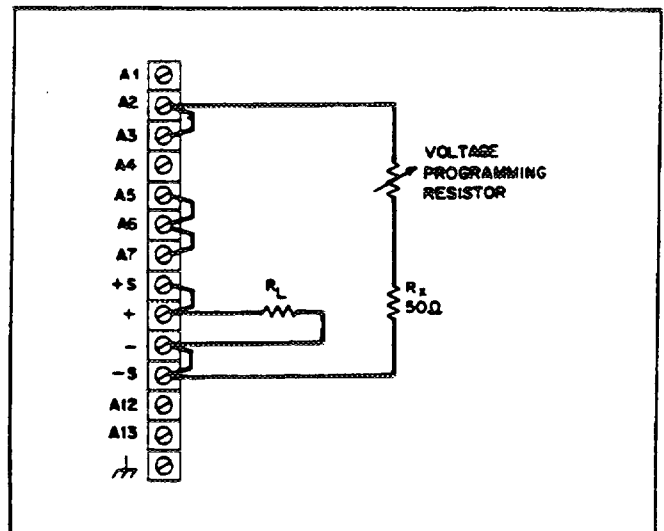

Figure 3-5. Resistance Programming of Output Voltage

voltage to be varied by using an external resistor to program the supply. The output voltage varies in accordance with the voltage control coefficient of 1000 ohms per volt. The output voltage will increase by approximately 1 volt for each 1000 ohms added across the programming terminals.) Note that voltage programming current determines the coefficient and that this programming current is factory adjusted to within 7% of 1mA. If a programming accuracy of greater than 7% is required, resistor A1R15 can be adjusted to obtain an accuracy of up to 0.5% (refer to Section V).

3-40 Resistor  $R_X$  replaces the internal 50Ω offset resistor (A2R1) that is disconnected (along with the front panel control) by the connections of Figure 3-5. The addition of  $R_X$  will bring the output voltage to near zero volts when the external programming resistor is set to minimum. If an output voltage that is closer to zero than this is required, it can be obtained by substituting a 100 ohm potentiometer in place of  $R_X$ . This potentiometer can then be adjusted to obtain exactly 0V output when the external programming resistor is set to minimum.

#### NOTE

*If the programming terminals (A2 to -S) become open circuited during resistance programming, the output voltage will tend to rise above rating. The supply will not be damaged if this occurs but the overvoltage trip point should be properly adjusted to protect the users load.*

3-41 **Constant Voltage Output, Voltage Control (Unity Gain).** The rear panel connections shown in Figure 3-6 allow the output voltage to be varied by using an external

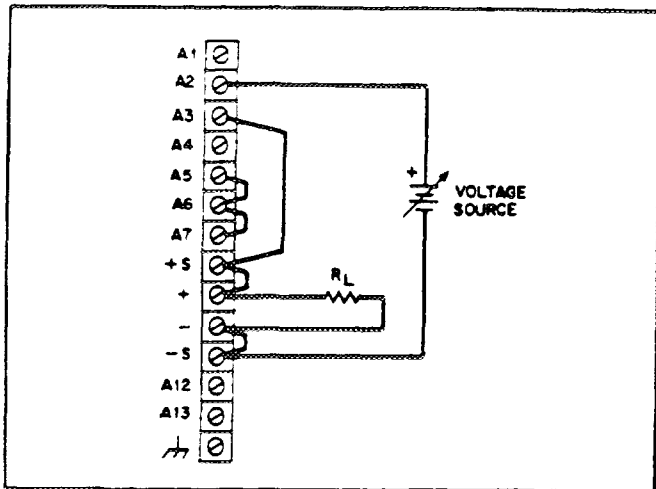

Figure 3-6. Voltage Programming of Output Voltage (Unity Gain)

voltage source to program the supply. In this mode, the output voltage varies in a 1 to 1 ratio with the programming voltage. The load on the programming voltage source is less than 20 microamperes. Note that the voltage control coefficient contains a fixed offset voltage of 50mV in addition to the tolerance of  $\pm 20\text{mV}$ . This means that the external voltage source will have to be set slightly higher than the output voltage. For example, to obtain an output of 50V, the external source would have to be set from 30 to 70mV higher than 50V.

**3-42 Constant Voltage Output Voltage Control (Variable Gain).** The arrangement of Figure 3-7 shows a method of programming the supply with gain using a variable voltage source ( $E_S$ ). Note that this method is no different than the circuit normally used within the supply except that an external reference source ( $E_S$ ) replaces the +6.2V internal reference and resistor  $R_X$  replaces the constant voltage pullout resistors (A1R12-R15). The voltage gain (between  $E_S$  and  $E_{OUT}$ ) is equal to the resistance ratio  $R_P/R_R$ .

**3-43 Reference resistor  $R_R$**  must be less than 10k ohms and must be selected so that the programming current flowing through it is at least 1 milliamp when the voltage source ( $E_S$ ) is set to maximum. Once  $R_R$  is selected, multiply it by the maximum voltage gain desired to find  $R_P$ . If desired, the power supply's front panel voltage controls can be used in place of external gain control  $R_P$  by deleting the external gain control from the circuit and strapping together terminals A1 and A2. Of course, a fixed external resistor can also be used in place of  $R_P$  if required. In any event, both  $R_P$  and  $R_R$  should be precision, wire-wound resistors. Notice that an offset voltage exists in this mode similar to that in unity gain voltage programming (paragraph 3-41). If an external gain control is used, this offset voltage will be 70mV (maximum). If the front panel voltage control is used the offset voltage will be less (20mV, maximum).

**3-44 Constant Current Output, Resistance Control.** The rear panel connections shown in Figure 3-8 allow the output current to be varied by using an external resistor to program the supply. The supply's constant current programming current, which is factory adjusted to  $500\mu\text{A} \pm 7\%$  determines the exact value of its programming coefficient of 100 ohms per Ampere. If the 7% accuracy of this coefficient is not adequate, it may be adjusted to within 0.5% with internal potentiometer A1R1 (refer to Section V).

**3-45 Resistor  $R_X$**  (15 ohms) replaces internal resistor A1R3 which is disconnected, along with the front panel current control, by the connections of Figure 3-8. This resistor provides a small amount of end resistance so that the output current can be adjusted to exactly zero (by A1R6) when the current programming resistor is shorted, or set to minimum. Section V gives the adjustment procedure for zeroing the output current using the internal offset adjust potentiometer, A1R6.

----- CAUTION -----

*Do not allow programming terminals A4 or A6 to become open-circuited while resistance programming the output current. If they do open, the supply's output current rises to a value that may damage the supply or the load. If in the particular programming configuration used there is a chance that the terminals might open, we suggest that a 1k ohm protection resistor be connected across the programming terminals. Of course, when this resistor is used, the resistance value actually programming the supply is the parallel combination of the remote programming resistance and the resistor across the programming terminals. Like the programming resistor, this resistor should be a low noise, low temperature coefficient type.*

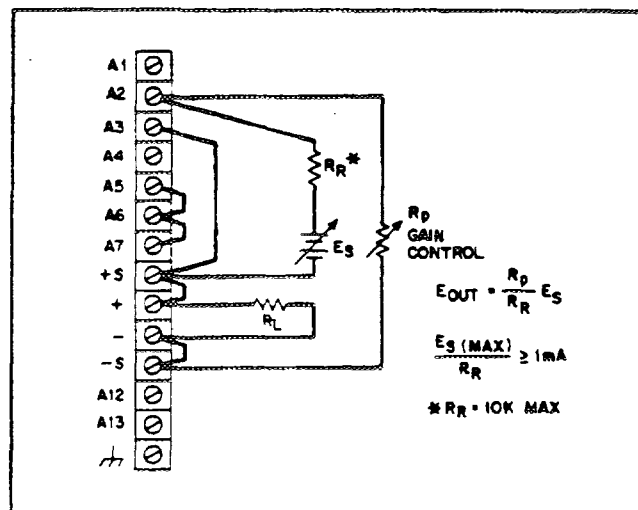

Figure 3-7. Voltage Programming of Output Voltage (Variable Gain)



**3-46 Constant Current Output, Voltage Control.** In this mode (Figure 3-9) the output is varied by the external voltage source at a rate established by the programming coefficient of  $50\text{mV/A} \pm 10\%$ . The external voltage required to obtain maximum rated output current from the supply is about  $500\text{mV}$ . An input greater than  $600\text{mV}$  will cause excessive power dissipation and possible damage to the supply. The load on the external voltage source will be less than  $20$  microamperes.

**3-47** To adjust the output current to exactly zero with a zero programming voltage, adjust A1R6 as outlined in Section V.

### 3-48 Auto-Parallel Operation

**3-49** Figure 3-10 shows the interconnections required to auto-parallel two units. This mode of operation provides a greater current capacity than can be obtained from a single supply while maintaining nearly equal load sharing among the paralleled supplies under all load conditions. Only supplies having the same model numbers can be used in auto-parallel unless the supplies all have equal current ratings and the voltage drop across the monitoring resistor in each supply is equal at maximum rated current.

**3-50 Additional Slave.** One additional slave supply can be added in parallel to the master/slave combination shown in Figure 3-10. All connections between the master and slave number one are duplicated between slave number one and the added supply (slave number two). The remaining terminals on slave number two should be strapped the same as those shown for slave number one on Figure 3-10.

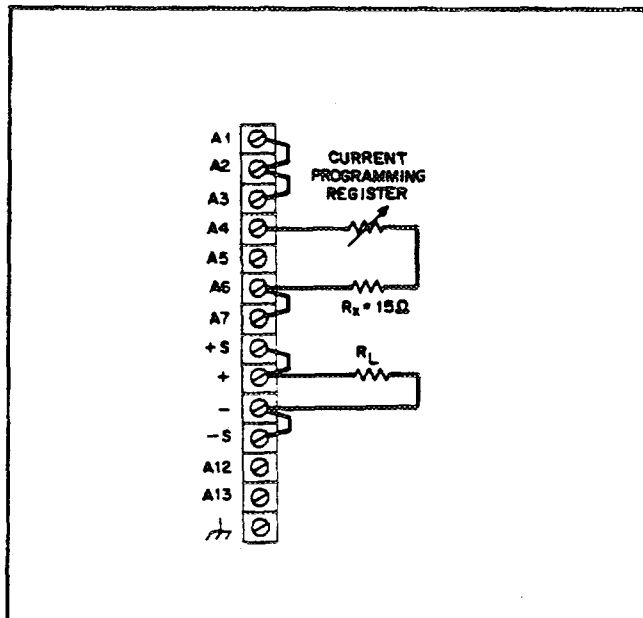

Figure 3-8. Resistance Programming of Output Current

### NOTE

*Use wires of equal length and gauge to connect each auto-parallel supply to the load. Load sharing will not be equal unless the positive leads connecting each supply to the load are all equal in resistance.*

**3-51 Setting the Voltage and Current Controls.** The auto-parallel combination of two or three supplies behaves as if it were a single constant-voltage/constant-current supply controlled by the voltage and current controls of the master supply. The voltage control of the slave(s) is disabled, but its current control remains operative and must be set to maximum to prevent a slave supply from independently reverting to constant current operation as would occur if the output current setting of the master supply exceeded that of the slave.

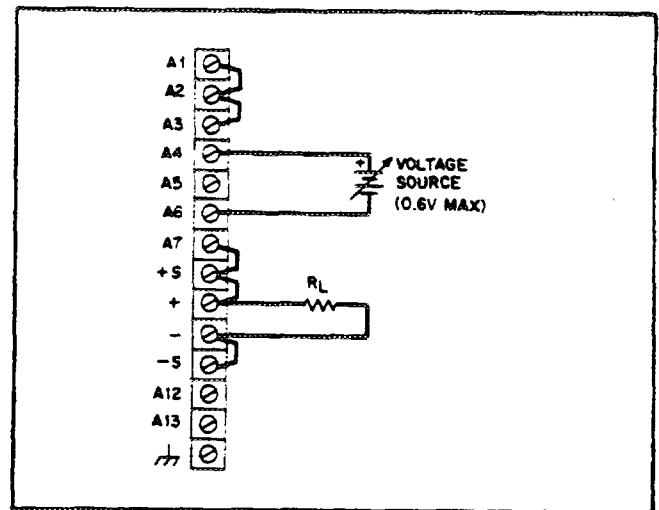

Figure 3-9. Voltage Programming of Output Current

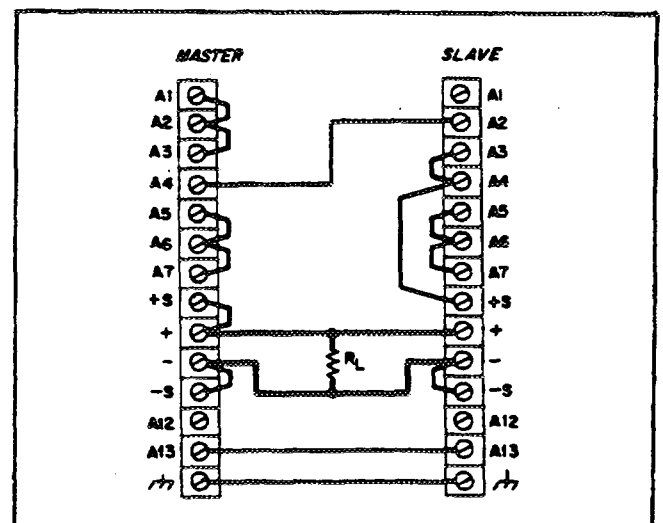

Figure 3-10. Auto-Parallel Operation of Two Units

**3-52 Overvoltage Protection in Auto-Parallel.** The interconnections shown in Figure 3-10 between the external crowbar trigger terminals on the master and on the slave(s) must be made to permit the overvoltage crowbar in the master to fire the SCRs in the master and the slave(s) if an overvoltage condition occurs. Be sure to connect them with the correct polarity shown. Set the slave supply overvoltage control(s) to maximum (clockwise) to disable them, and adjust the overvoltage trip point at the master supply.

**3-53 Auto-Parallel With Remote Sensing.** To combine auto-parallel operation with remote sensing, connect the supplies as described above but remove the +S and -S jumpers from the master supply and connect the +S and -S terminals directly to the (+) and (-) ends of the load. Observe the precautions outlined under paragraph 3-27.

**3-54 Auto-Parallel With Remote Programming.** When two or three supplies are connected in auto-parallel, their combined output voltage, current, or both can also be remotely programmed from the master supply. Observe all precautions outlined in the paragraphs on remote programming. The simultaneous use of remote sensing and remote programming is also possible during auto-parallel operation.

**3-55 Auto-Series Operation**

**3-56 Auto-series operation** provides greater output voltage capability than that available from one supply. A maximum of three units can be used in this configuration. Figures 3-11 and 3-12 show the rear panel and circuit board interconnections required to operate two or three supplies in auto-series. This mode of operation allows the series-connected supplies to be simultaneously programmed by the voltage and current controls of a master supply. The master supply must always be the one at the positive end of the series combination. The output voltage of each slave supply varies in direct proportion to that of the master and the ratio of each slave's output voltage to the master's is established by the settings of the slave supplies' voltage controls. The resulting combination of two or three supplies behaves as if it were a single constant-voltage/constant-current supply. The supply with the lowest current setting limits the maximum output current of the combination. Mixed model numbers can be employed in auto-series combination, provided that each slave is capable of auto-series operation. Any well-regulated, variable output supply can be used as the master.

**3-57** In applications where coordinated positive and negative voltages are required, grounding the center tap of an auto-series combination of supplies allows simultaneous proportional control of both supply voltages.

**3-58 Value of  $R_X$ .** As shown, each slave supply has an external resistor  $R_X$  that provides its' voltage programming current. The value of  $R_X$  is determined by dividing the constant voltage programming current of the slave supply into the maximum rated output voltage that will be received from the master supply. For two Model 6002A supplies,  $R_X$  would be  $50V/1mA = 50k$  ohms. To maintain the temperature coefficient and stability specifications of the supplies,  $R_X$  must be a stable, low noise resistor with a temperature coefficient of less than 30ppm per °C and a power rating of at least 30 times what it will actually dissipate.

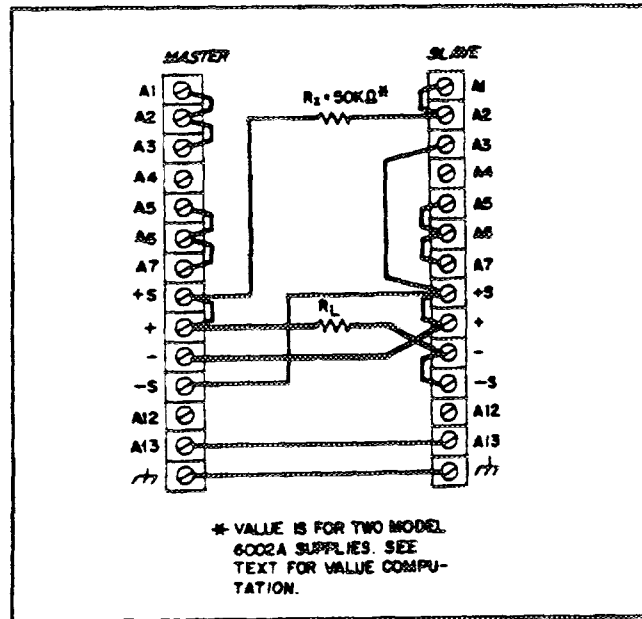

Figure 3-11. Auto-Series Operation of Two Units

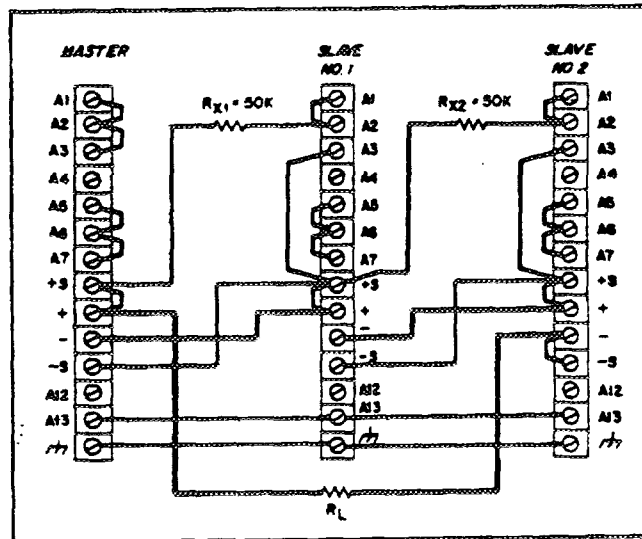

Figure 3-12. Auto-Series Operation of Three Units

**3-59** When operating three supplies in auto-series,  $R_{X2}$  is found by dividing the voltage programming current of the second slave into the maximum voltage expected from the first slave.

**3-60** **Setting the Voltage Controls.** The voltage each slave supply contributes is determined by its voltage control setting. The output voltage of the first slave supply tracks the voltage of the master, and the voltage of the second slave (if used) tracks the voltage of the first slave. For this reason, the voltage of the master must be adjusted to maximum, and then each slave, in turn, must be set to the corresponding voltage desired during initial setup of the auto-series combination. Once this has been done, the total voltage of the combination can be controlled by the voltage controls of the master supply or it can be remotely programmed through the master supply.

**3-61** **Setting the Current Controls.** Auto-series operation leaves the current controls of all supplies operative, but the supply whose current control has the lowest setting determines the point at which automatic crossover to constant current operation begins to lower its output voltage and thus that of the series combination. The constant current circuit of a supply has no effect on the outputs of the supplies connected in a more positive position in the series combination, but it does affect its own output and the outputs of the supplies connected in a more negative position. If the current controls of one of the slave supplies are set the lowest, then an overload or short circuit at the output will cause the master supply (or the master and the first slave) to force current through the reverse voltage protection diodes at the outputs of the downstream slaves. Because this current could be excessive either for the diodes or the load, the current controls of the slave supplies should be set to maximum and the master supply's current controls used to establish the output current or current limit.

**3-62** **Overvoltage Protection in Auto-Series.** The interconnections shown in Figures 3-11 and 3-12 between the external crowbar trigger terminals on the master and on the slave(s) must be made to permit the overvoltage crowbar in any one of the interconnected supplies to fire the SCRs in all of them if an overvoltage condition occurs. Be sure to connect them with the polarity shown. Set the overvoltage potentiometer in each supply so that it trips at a point slightly above the voltage that supply will contribute.

**3-63** **Auto-Series With Remote Sensing.** To combine auto-series operation with remote sensing, connect the supplies as described above but remove the +S jumper from the master supply and the -S jumper from the last slave supply and connect the +S and -S terminals directly to the (+) and (-) ends of the load.

**3-64** **Auto-Series With Remote Programming.** When two or three supplies are connected in auto-series, their combined output voltage, current, or both can also be remotely programmed. Refer to the appropriate sections for the additional rear panel connections required and make these connections to the master supply only.

### 3-65 Auto-Tracking Operation

**3-66** Figures 3-13 and 3-14 show the rear panel interconnections required to operate two or three supplies in the auto-tracking mode. This mode of operation allows two or three supplies that share a common negative output bus to power separate loads and have their output voltage simultaneously programmed by the voltage and current controls of a master supply. Unless their outputs are to be equal, the supply that is to have the greatest output voltage must be selected as the master. The output voltage of each slave supply is a constant percentage of the master's with the percentage for each slave established by a voltage divider consisting of  $R_X$  and the voltage control of the slave supply. Model numbers can be mixed in an auto-tracking configuration.

**3-67** **Value of  $R_X$ .** To calculate the proper value of  $R_X$  the following information is required:

- $E_M$ , the maximum voltage desired from the master supply.
- $E_S$ , the maximum voltage desired from the slave supply.
- $R_p$ , the resistance of the slave supply's voltage control.

To find  $R_X$  use the formula:

$$R_X = (E_M R_p / E_S) - R_p$$

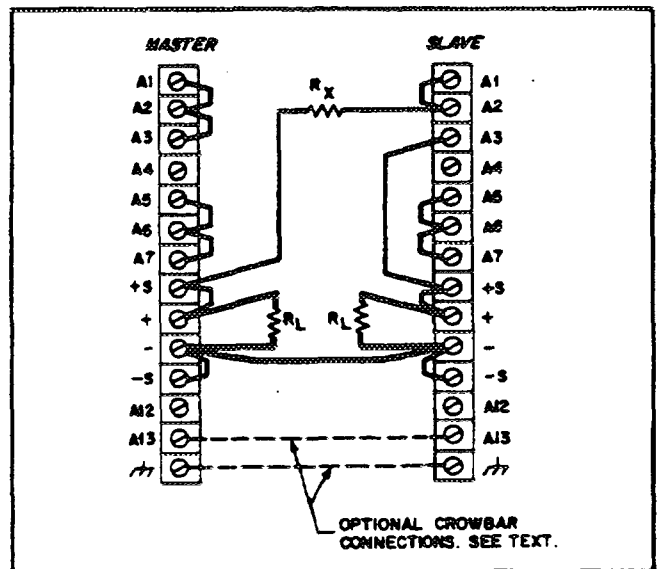

Figure 3-13. Auto-Tracking Operation of Two Units

For example, if two Model 6002A supplies are used in auto-tracking, and we want the slave's output to vary from zero to 20 volts as the master supply varies from zero to 50 volts, the value of  $R_X$  is:

$$R_X = (50V \times 50k\Omega / 20V) - 50k = 75k\Omega$$

**3-68** If the temperature coefficient and stability specifications of the supplies are to be maintained,  $R_X$  must be a stable, low noise resistor with a temperature coefficient of less than 30ppm per °C and a power rating at least 30 times what it will actually dissipate.

**3-69** Note that if the auto-tracking slave's voltage will equal the output of the master, the value of  $R_X = 0\Omega$ . In this case, make a direct connection from the +S terminal of the master to the A2 terminal of the slave and remove the slave's A1 to A2 jumper.

**3-70** **Setting the Voltage and Current Controls.** The voltage control settings for the master and slave supplies were discussed previously in paragraphs 3-66 through 3-69. The current controls of all supplies in an auto-tracking combination are independently operative and can be used to set current limits for each individual load. If the master supply goes into the constant current mode, the output voltages of the slaves continue to track that of the master. If a slave supply goes into constant current mode, however, no other supply is affected.

**3-71** **Overvoltage Protection in Auto-Tracking.** Paralleling the crowbar circuits, as is required for the auto-parallel and auto-series modes, is optional in the auto-tracking mode. If the extra crowbar windings in the master and in the slave supplies are not paralleled, the overvoltage protection circuit in each supply independently monitors the voltage across its own load. Then if the master supply crowbars, the output voltage of the slave(s) also decreases, but if one of the slaves crowbars, no other supply is affected.

**3-72** In order to have all supplies in an auto-tracking combination crowbar simultaneously if any of them has an overvoltage condition, parallel their crowbar circuits as shown in Figure 3-13 or 3-14. Set the overvoltage potentiometer in each supply so that it trips at a point slightly above the voltage that supply will provide.

**3-73** **Auto-Tracking With Remote Sensing.** To combine auto-tracking operation with remote sensing, connect the supplies as described above but remove the +S and -S jumpers from each supply and connect the +S and -S terminals directly to the (+) and (-) ends of its load.

**3-74** **Auto-Tracking With Remote Programming.** When two or three supplies are connected for auto-tracking operation, their output voltages can be remotely programmed at the master supply. The output current of the slave supplies cannot be controlled from the master as pointed out in paragraph 3-70. The simultaneous use of remote sensing and remote programming of the output voltage is possible during auto-tracking operation.

**3-75** **Constant Current Status Signal.** A signal from the output of the current comparison amplifier is brought out to terminal A12 on the rear of the unit. This signal switches from low (approximately 0.5V with respect to 0) to high (approximately +6V) when the supply goes into the constant current mode. This signal can be readily amplified to perform system tasks required by the user.

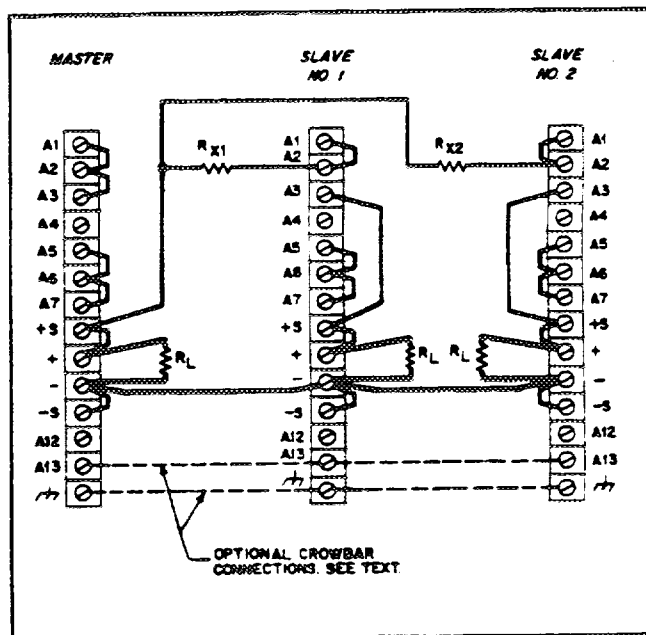

Figure 3-14. Auto-Tracking Operation of Three Units

## SECTION IV PRINCIPLES OF OPERATION

### 4-1 DIFFERENCE BETWEEN STANDARD LAB SUPPLY AND EXTENDED RANGE SUPPLY

4-2 The basic difference between a conventional Constant Voltage/Constant Current (CV/CC) power supply and an extended range supply is readily seen by comparing the output characteristic of each type. Figure 4-1 (A) shows that maximum output power (200 Watts in the example) from a standard supply can be obtained at only one point on its' rectangularly shaped locus. Maximum output power from the 6002A supply, however, is available at many points along a "constant power" curve ranging from a 50V, 4A to 20V, 10A (see Figure 4-1 (B)). Thus, one extended range supply provides maximum output power over a wide range of voltage and current combinations.

### 4-3 OVERALL DESCRIPTION

4-4 Figure 4-2 is a simplified schematic showing the major circuits of the supply. For simplification, two of the supplementary circuits (operating mode indicator and meter circuits) have been omitted from the diagram. The

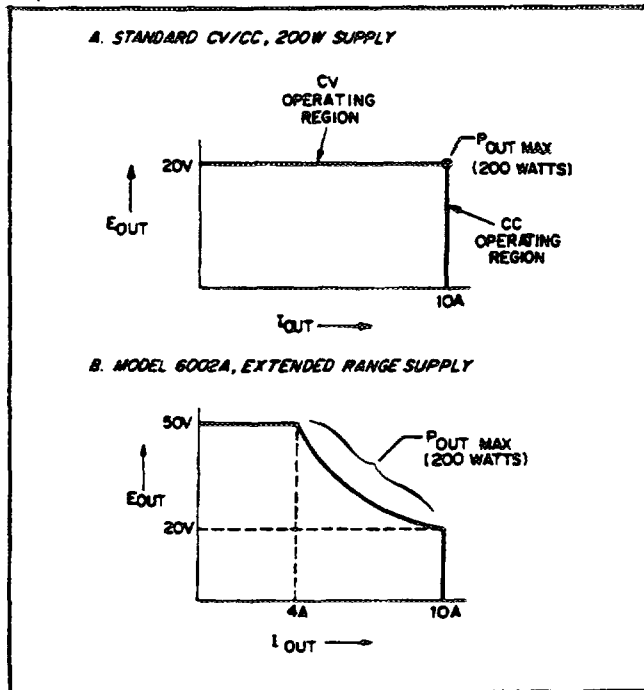

Figure 4-1. Output Characteristics,  
Standard vs. Extended Range

supply is shown in its entirety on the main schematic at the rear of the manual. On both the main and simplified schematic diagrams, the functional circuit designations are the same so that both diagrams can be correlated.

### 4-5 Major Circuit Divisions

4-6 The supply can be divided into three major circuit groups: a series regulator feedback loop, an overvoltage protection "crowbar", and a tap selection and control circuit. A supplementary reference supply is also included to provide regulated and unregulated bias voltages used throughout the supply by the major circuit groups. Both the series regulator feedback loop and the overvoltage crowbar circuit are very similar to those used in many other laboratory type power supplies manufactured by Hewlett-Packard. The tap selection triacs and control logic, however, are related only to extended range power supplies. It is these circuits that govern the extended output characteristic shown in Figure 4-1 (B).

### 4-7 Tap Selection Triacs and Control Logic

4-8 These circuits consist of a pair of triac switches operating under control of the tap selection control logic. The function of these circuits is to control the amplitude of the ac that is applied to the rectifier-filter. As indicated on Figure 4-2, the top and bottom taps on the secondary of T1 are connected to the triacs, A3CR1 and A3CR2. During each half cycle of the input ac, one of four possible tap combinations (and corresponding ac levels) is selected by the triacs for connection to the rectifier-filter. The particular secondary tap combination that is selected is based on the load demands and the condition of the ac line. The control logic makes the determination by monitoring the output voltage and current, and the ac line and then issuing the appropriate firing pulses to the switches. To minimize RFI noise, the triacs are fired only when the voltage across them is minimal.

4-9 As an example of when the different secondary windings are switched, refer to Figure 4-3. As indicated, the output characteristic is divided into four operating regions with each region having a corresponding combination of secondary turns ratios. For low output voltages, the control logic forces the supply to operate in region number one by holding CR1 and CR2 off. Thus, only the middle winding is connected to the rectifier-filter and it receives a relatively low ac input level. For high voltage/low current

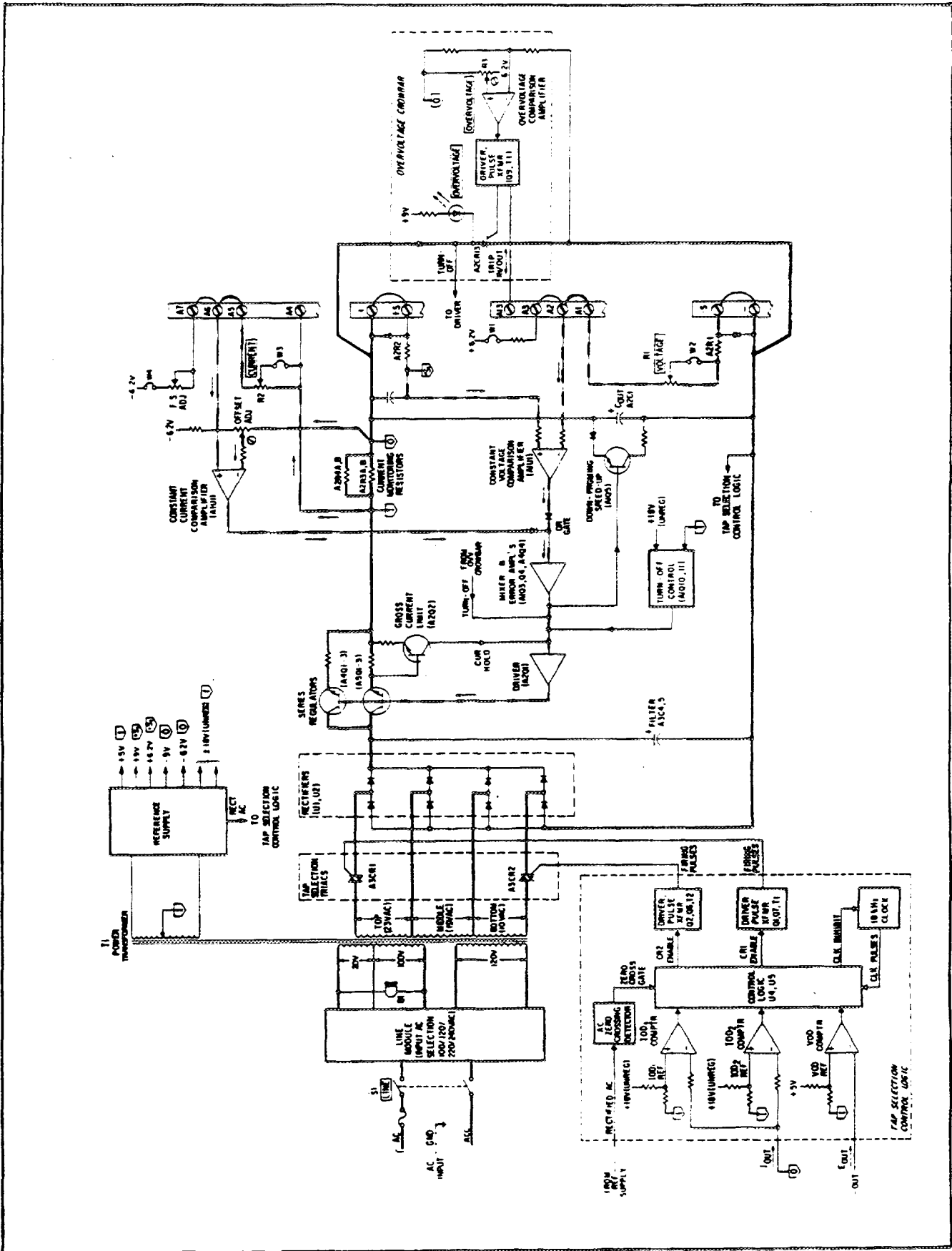

Figure 4-2. Simplified Schematic

conditions (region number two on Figure 4-3), the control logic fires both triacs and the entire secondary voltage (middle, top, and bottom windings) is connected to the rectifier-filter. For each of the other two regions (three and four), one of the triacs is on and the other is off, adjusting the ac input accordingly. Switching between operating regions occurs automatically and can be updated every half cycle of the input ac, as previously mentioned.

4-10 Notice on Figure 4-3, that the four operating regions are determined by an output voltage decision line (VOD) and two output current decision lines ( $IOD_1$  and  $IOD_2$ ). These decision lines serve as reference points and are established by a set of three comparators (Figure 4-2). The VOD comparator compares a sample of the output voltage (voltage between  $-OUT$  terminal and  $\text{Ⓜ}$ ) with a dc reference level (VOD reference). If the output voltage is less than the VOD reference, the output of the comparator causes the generation of a clock inhibit signal to the 18kHz clock halting all clock pulses. With no clock pulses applied to the control logic, no firing pulses can be generated and both triacs are held off. Under these conditions, the supply is made to operate in region one of Figure 4-3. On the other hand, if the output voltage is greater than the VOD reference, the 18kHz clock is allowed to run and one, or both, of the triacs is fired based on the output of the IOD comparators.

4-11 The IOD comparators monitor the output current of the supply by sensing the IR drop across the current monitoring resistors (voltage between  $\text{Ⓜ}$  and  $\text{Ⓞ}$ ). The effective output current is then compared with an IOD reference voltage and the comparator output is used by the control logic as the basis for firing one, or both, of the triacs. Thus, whenever the IOD comparators have control, the supply operates in region two, three, or four of Figure 4-3. The zero cross detector generates a gate, each time the ac input passes through zero. This gate serves as an "update window" during which time the control logic changes state to reflect the condition of the comparators. Notice that the IOD reference voltages are both derived from an unregulated dc voltage (+18V unregulated). Because the +18V varies with the amplitude and frequency of the ac line, ac compensation is automatically built in to the circuit. The  $IOD_1$  and  $IOD_2$  reference points shown in Figure 4-3 are those associated with a nominal ac input (115Vac, 60Hz). If the ac line voltage increases both IOD reference points shift to the left (by approximately 15% at high line) to a lower current level. The reverse occurs, if the ac line voltage decreases.

#### 4-12 Series Regulator Feedback Loop

4-13 The raw dc, previously adjusted to the proper level by the tap selection triacs, is applied to the series regulating transistors. The conduction of these transistors is made to

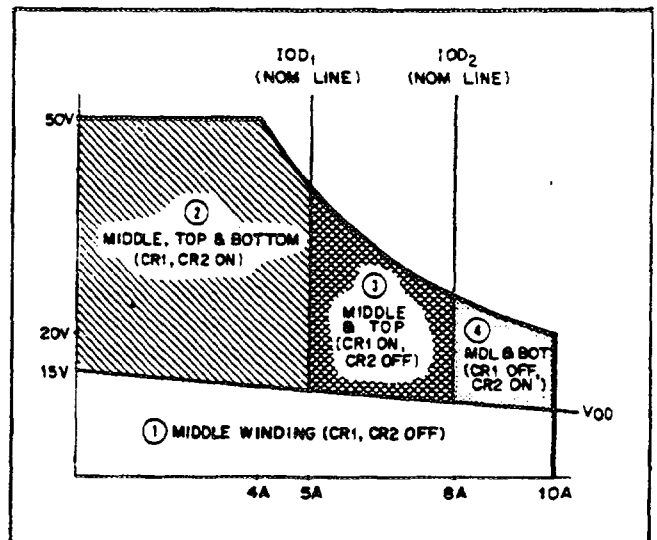

Figure 4-3. Four Operating Regions

vary so that a regulated voltage or current is available at the output terminals. The series regulating transistors are part of a feedback loop consisting of the driver and error amplifiers, the constant voltage comparison amplifier, and the constant current comparison amplifier.

4-14 For normal operating conditions, the feedback signals that control the conduction of the series regulator originate either in the constant-voltage or constant-current comparison amplifiers. During constant-voltage operation the constant-voltage comparator compares the output voltage of the supply with the drop across the VOLTAGE control. If these voltages are not equal, the comparison amplifier produces an error signal that is further amplified and fed back to the series regulator in the correct phase and amplitude to make them equal. In this manner, the constant-voltage comparator holds the output voltage constant and at the level established by the VOLTAGE control.

4-15 During constant-current operation, the constant-current comparison amplifier detects any difference between the voltage drop developed by load current flowing through the current monitoring resistors and the voltage across the CURRENT control. If the two inputs to the comparator are momentarily unequal, an error signal is generated that alters the conduction of the series regulator by the amount necessary to reduce the error voltage to zero. Hence, the IR drop across the current monitoring resistance, and therefore the output current, is held at a constant value.

4-16 Since the constant-voltage comparator causes the output impedance to be low and allows the output current to change whenever the load resistance changes, while the constant-current comparator causes the output impedance to be high and allows the output voltage to change in response to a load resistance change, it is obvious that the two com-

parison amplifiers cannot control the output simultaneously. For any given value of load resistance within the 200W operating limits, the power supply must act either as a constant-voltage source or as a constant-current source. To enable one comparator or the other to take control, the outputs of both comparators are connected to the input of the mixer amplifier through an OR gate.

**4-17 Operation of Loop During Overrange.** Throughout the previous discussion, it was assumed that the supply was operating normally, within the 200W operating limits, in either the constant voltage or constant current mode. However, as described in Section III, it is possible for this supply to operate outside the 200 Watt operating limits if the voltage or current control is set too high relative to the load impedance that is connected across the supply. If the supply is in an overrange condition, neither the voltage nor current comparator controls the feedback loop and both OR gate diodes are reverse biased. With the OR gate off, the series regulator will conduct heavily due to the internal biasing of the mixer amplifier stage inside the feedback loop (refer to paragraph 4-37 for more details).

**4-18 Supplementary Circuits.** To improve the performance of the supply, three supplementary circuits are used to control the feedback loop during certain operating conditions. The turn-off control circuit minimizes output overshoot whenever the supply is turned off. The circuit is activated only at turn off by the rapidly shrinking +18V (unregulated) bias and sends a turn down signal to the series regulator via the driver.

**4-19 Transistor A1Q5 and associated components speed-up the down programming capabilities of the supply.** This transistor is off unless the output is rapidly down-programmed by the front panel control or a remote programming source. Under these conditions, A1Q5 is turned on by a negative going signal from the feedback loops error amplifier, providing a low resistance discharge path for output capacitor A2C1.

**4-20 The gross current limit transistor, A2Q2, provides backup protection for the constant current comparison amplifier.** This transistor monitors a portion of the output current (IR drop across one of the series regulator emitter resistors) and generates a "hold" signal to the driver if the output current attempts to exceed approximately 120% of maximum rating.

#### 4-21 Overvoltage Protection Circuit

**4-22 This circuit protects loads against excessively high voltage, as might result from a series regulating transistor failure.** It monitors the output voltage of the supply (between -OUT and ) , and fires an SCR "crowbar"

if the output exceeds the threshold set by the OVER-VOLTAGE control. Once fired, the SCR (A2CR13) effectively short circuits the output of the supply. The crowbar circuit also sends a turn-off signal to the series regulator when it is fired.

#### 4-23 DETAILED CIRCUIT DESCRIPTION

**4-24** The following paragraphs describe, in more detailed terms, the operation of the supply's major circuits. Note that only those circuits not covered in sufficient detail in the preceding overall description, will be described. Throughout this discussion refer to the fold-out schematic diagram at the rear of the manual.

#### 4-25 Tap Selection Control Logic

**4-26** As mentioned previously, the function of these circuits is to provide the constant power output characteristic shown on Figure 4-1 (B). To accomplish this, the circuit controls the conduction of a pair of triac switches which, in turn, control the raw dc that is applied to the series regulator. A decision to fire one, both, or neither of the triacs is made once during each half cycle of the input ac (8.33 milliseconds) based on the output voltage and current of the supply and the amplitude and frequency of the ac line.

**4-27** Figure 4-4 shows the control logic waveforms associated with each of the four basic operating conditions discussed previously (paragraphs 4-9 through 4-11). During the first time period (starting at  $t = 0$ ) the output voltage sample is less than the VOD reference voltage at pin 5 of U3 and the output of the comparator is low (approximately  common). The output of the VOD latch ( $\overline{Q1}$  side of flip-flop 1) is high (approximately +5V) causing Q12 to conduct and clamp the clock line low. With the clock line held low, the output of the U4 NAND gates (pins 10 and 11) are maintained at a high level and no firing pulse can be generated regardless of the condition of the IOD inputs to the gates. As indicated on Figure 4-4, both triacs are off at this time and only the middle winding is connected to rectifiers U1 and U2.

**4-28** Starting at time period two and extending through the remaining time periods in the example, the output voltage is greater than the VOD reference. The VOD flip-flop is consequently switched to the set state ( $\overline{Q1}$  side goes low), permitting the continuous application of 18kHz clock pulses to the U4 control gates (pins 9 and 13). Which control gates are enabled, now depends on the state of the IOD latches which, in turn, is dependent upon the amplitude of the output current. During time period 2, the sample output current is greater than the IOD<sub>2</sub> reference voltage and the output of both IOD comparators are high. The output of



the  $IOD_2$  latch (F/F2) is low so that the upper NAND gate is enabled (high level at U4-12) and the lower gate is disabled (low at U4-8). Thus, the clock pulses are allowed to pass through Q6 but are blocked from entering Q7. As a result, triac CR2 is conducting during the second time period while CR1 is held off.

4-29 Note that at sometime after the maximum ( $90^\circ$ ) point of each half cycle the triacs will cut off because the voltage across them is not sufficient to maintain conduction. The triacs remain cutoff through zero crossing and well into the next half-cycle until their minimum firing potential is exceeded. The first firing pulse that is received after this time will fire the triac(s) and the remaining pulses, received during the rest of the half cycle, will have no effect. The zero crossing detector U4, ensures that the firing decisions are always updated near the zero crossing point of the ac line, while the triacs are cutoff. As shown on Figure 4-4, the three decision latches cannot change state until the leading edge of the zero cross gate (TP5) is generated, even though the associated comparator may have changed state earlier in the half cycle.

4-30 Time period three in the example of Figure 4-4, is initiated when the output current falls below the  $IOD_2$  reference point. The output of the  $IOD_2$  comparator switches low at this time and at the next zero crossing point, the  $IOD_2$  latch is switched to its reset state ( $\overline{Q2}$  output goes high). The condition of the triacs during time slot three is the exact reverse of the conditions during time slot two; with CR1 conducting and CR2 off.

4-31 Time period four is initiated when the output current falls below the  $IOD_1$  reference point. The action of the comparators and latches during this time period is essentially the same as that for the previous time periods.

### 4-32 Operation of Feedback Loop

4-33 The feedback loop functions continuously to maintain a constant output voltage or current and a good understanding of it's operation is very helpful in troubleshooting the supply.

4-34 For purposes of this discussion, assume that the unit is in constant voltage operation and that the VOLTAGE control, R1, has been adjusted so that the supply is providing the desired output voltage. Further assume that the output voltage instantaneously rises due to a variation in the external load circuit.

4-35 The instantaneous increase in output voltage causes the inverting input of the CV comparison amplifier (U1-6) to go negative. The resultant positive going error voltage from U1 is amplified and inverted by mixer

amplifier A1Q4 and fed to the bases of all six series regulating transistors via emitter followers A4Q4 and A2Q1. The negative going input to the regulating transistors results in a decrease in their conduction so that the output voltage is reduced to it's original level.

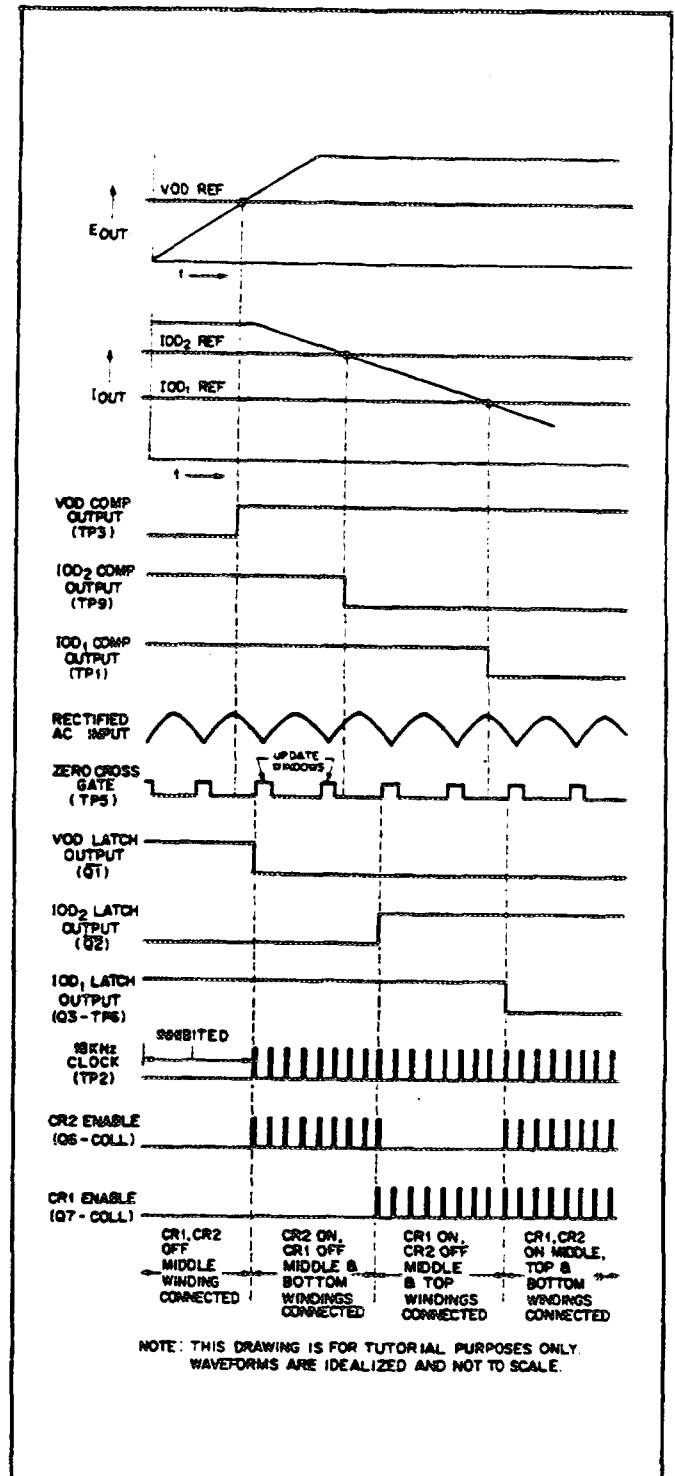

Figure 4-4. Control Logic Waveforms for Various Output Conditions

**4-36** Constant current operation is initiated if the load resistance decreases below a certain crossover point, as described in Section III. Under these conditions, the increased output current causes the output of the current comparison amplifier (at U1-1) to become sufficiently positive to forward bias OR – gate diode A1CR4. At the same time the output voltage decreases, so that OR – gate CR11 becomes reversed biased and the supply is in the constant current mode. Feedback loop operation in the constant current mode is similar to that occurring during the constant voltage mode except that the input to the current comparison amplifier is obtained from the current monitoring resistors.

**4-37** As mentioned previously in paragraph 4-17, both OR – gate diodes (CR4 and CR11) are reversed biased if the unit is mistakenly placed in an overrange condition. With both diodes off, mixer amplifier A1Q4 conducts heavily due to the –9V bias connected to its base through R27. The resultant positive voltage at the collector of Q4 is feedback to the series regulator, via Q4 and Q1, causing it to conduct heavily. The supply now operates somewhere in the overrange region at a point determined mainly by the beta of the series regulating transistors. Although the supply will not be damaged when operating in overrange, it will not meet specifications in this area.

**4-38** Main output capacitor A2C1, connected across the output of the supply, helps stabilize the feedback loop for all types of loads. Additional stabilization is provided by local feedback networks used by various stages within the loop.

#### **4-39 Series Regulator**

**4-40** The series regulator consists of six transistors connected in parallel to minimize the power dissipated in any one transistor. Protection diode A2CR8, connected across the regulator, protects the transistors from possible damage by reverse current flow. Thermal switch A5TC1 will open, turning off the series transistors, if the heat sink temperature exceeds approximately 248°F. This feature protects critical components from the excessive temperatures that could occur due to a cooling fan failure. Diode A2CR7 conducts if the thermal switch opens, reverse biasing the base-emitter junctions of the series transistors thus turning them off. An additional safety factor is provided by connecting the top and bottom heat sink boards in such a manner that a base interlock system is formed. Thus, if either heat sink board is removed, the base path to the series transistors on the remaining board is opened and no damage can occur if power is applied to the unit.

**4-41** Two dc fuses (A3F1, F2) provide additional protection for the regulator and other critical components of

the supply. One, or both, of these fuses will blow if a series regulator or driver transistor shorts and the unit crowbars (conducting SCR is placed across supply).

#### **4-42 Driver, Error, and Mixer Amplifiers**

**4-43** These stages amplify the error signal received from the voltage or current comparison amplifiers to a level sufficient to drive the series regulator. Mixer amplifier Q4, is the first stage in the string and receives its input from the OR – gate diode that is conducting at the time (CR4 or CR11). Transistor A1Q3 provides a constant current to the collector of Q4. Two degenerative feedback networks (R28-C4 and R31) are included to stabilize the feedback loop.

**4-44** Transistors A2Q1 and A4Q4 serve as the driver and predriver elements, respectively, for the series regulator. Error amplifier A4Q4 also provides a discharge path for the output capacitance in order to enhance the down programming speed of the supply. This circuit assists the down-programming transistor A1Q5 mentioned previously in this section. The discharge path for the output capacitance is through A1CR12, A1R32, and A4Q4 to the negative output terminal.

#### **4-45 Constant Voltage Comparison Amplifier**

**4-46** This circuit consists of differential amplifier U1, VOLTAGE control R1, and associated components. The non-inverting input of the differential amplifier is connected to the circuit common point (+S<sub>1</sub>) through impedance equalizing resistor A1R18. The other input of the differential amplifier (pin 6) is connected to a summing point (terminal A2) at the junction of the voltage control and the current pullout resistors R12-R15. Instantaneous changes in the output voltage or changes in the VOLTAGE control setting produce a difference voltage between the two inputs of the differential amplifier. This difference voltage is amplified and appears at the output of the amplifier (pin 7) as an error voltage which ultimately varies the conduction of the series regulator.

**4-47** Diode CR7 prevent excessive voltage excursions from overdriving U1. Feedback network C3, R21 helps stabilize the amplifier. Capacitors C1, and A2C4, connected across the front panel and rear panel output terminals, both help to suppress output spikes.

**4-48** During constant-voltage operation, the programming current flowing through the voltage control is constant because the summing point is held at zero volts (with respect to ) by feedback action and virtually all of the +6.2V reference supply current flowing through pull-out resistors R12-R15 flows through the VOLTAGE control.

Linear constant-voltage programming is thus assured. Potentiometer R15 serves as a trimming adjustment for the programming current flowing down through the network. This potentiometer establishes the constant-voltage programming accuracy and is adjusted so that the supply can provide maximum rated output when the VOLTAGE control is set to maximum.

**4-49** Diode CR6 becomes forward biased only when the supply is in constant current operation. This diode shunts the constant voltage programming current, (which varies during constant current operation), around the current monitoring resistors, through meter circuit buffer U2. If the programming current were allowed to flow through the current monitoring resistors, it would be erroneously interpreted as a load change by the current comparison amplifier.

#### **4-50 Constant-Current Comparison Amplifier**

**4-51** This circuit is similar in appearance and operation to the constant voltage comparison amplifier. It consists of differential amplifier U1, a CURRENT control, and associated components.

**4-52** The inverting input of U1 (pin 2) is connected to the circuit's common point (0) through R8 and a zero offset adjust potentiometer, R6. The non-inverting input is connected to a summing point (terminal A6) between the CURRENT control and current pullout resistors R1 and R2. Instantaneous changes in the output current due to load changes or changes in the voltage at the summing point due to changes in the CURRENT control setting produce a difference voltage between the two inputs of the differential amplifier. This difference voltage is amplified and appears at the output of the differential amplifier (pin 1) as an error voltage which ultimately varies the conduction of the series regulator.

**4-53** Potentiometer A1R1 is adjusted so that maximum rated output current can be obtained with the front panel CURRENT control. This potentiometer provides control of the constant current programming accuracy in the same manner as R15 in the constant voltage circuit.

#### **4-54 Operating Mode Indicator Circuit**

**4-55** This circuit provides front panel status indications concerning the operating mode of the power supply. Three LED indicators are included; VOLTAGE MODE, CURRENT MODE, AND OVERRANGE. A fourth status indicator (OVERVOLTAGE), is shown in the overvoltage crowbar circuit on the schematic.

**4-56** When the supply is in the constant voltage mode,

the error signal from the voltage comparison amplifier (pin 7) is sufficiently positive to drive A1Q1 into conduction, thus lighting the VOLTAGE MODE indicator. At this time, transistor A1Q2 and its associated CURRENT MODE indicator are off because of the relatively low output at pin 1 of the current comparison amplifier. If the supply crosses over to the constant current mode, the reverse situation occurs with transistor Q2 on and the CURRENT MODE indicator lit.

**4-57** As long as either one of the voltage or current indicators are lit, the OVERRANGE indicator is off because the voltage across Zener diode VR3 is too low to cause breakdown. However, if an overload occurs (supply operates in overrange region), the supply operates in neither the constant voltage nor the constant current mode and both A1Q1 and A1Q2 are cutoff. The reverse voltage across VR3 is now large enough to exceed its avalanche potential and the OVERRANGE indicator lights. The OVERRANGE indicator also lights if the overvoltage crowbar circuit is activated. Under these circumstances, the indicator lights because the series regulator receives a turn-off signal from the overvoltage circuit and neither the constant voltage nor constant current amplifier is in control of the feedback loop.

#### **4-58 Overvoltage Crowbar Circuit**

**4-59** This circuit protects loads against excessively high voltages by firing an SCR (A2CR13) if the output voltage exceeds a preset trip level. Once fired, the SCR becomes a virtual short circuit across the supply reducing the output voltage to near zero. Until it is triggered, the SCR acts as an open circuit and has no effect on the output voltage.

**4-60** A comparison amplifier, A1U10, monitors a portion of the output voltage and compares it with an adjustable reference voltage (trip level) established by the setting of OVERVOLTAGE adjust potentiometer, R3. During normal (non-overvoltage) operation, the output voltage at pin 2 of U10 is less than the reference voltage (pin 3 of U10) and transistor Q9 is held off. If the output voltage rises to a point where it exceeds the trip level, the negative potential at U10, pin 2, results in the conduction of transistor Q9. A positive going trigger pulse is then generated across pulse transformer T1, firing the SCR. When CR13 is fired, a path is completed for OVERVOLTAGE lamp (DS4) and it lights. At the same time, diode A2CR6 becomes forward biased turning off the driver (A2Q1) and series regulating transistors by conducting current away from the base of A2Q1. Turning off the series regulator when the unit crowbars is necessary to prevent the heating problems that could occur when short circuit current is drawn from the supply due to a failure in the feedback loop. This technique is satisfactory for any high voltage condition that is caused by a failure in one of

the stages before driver A2Q1 in the feedback loop. However, if the overvoltage condition is caused by a shorted series regulating or driver transistor, the turn-off signal from the crowbar circuit will have no effect. In this case, the excessive current flow through the regulator will cause one, or both, of the dc fuses (A3F1, F2) to blow, thus limiting the current flow.

**4-61** To keep the crowbar SCR conducting after the series regulator is turned-off or a dc fuse blows, two holding current paths are provided. One holding path is provided by the +9V bias, through resistor R110 and OVERVOLTAGE indicator DS4. An alternate holding path is provided by diode A2CR6 which conducts as soon as the SCR fires. The SCR remains in conduction until the supply is turned off. Thus, to reset the crowbar, the supply must be turned off and then back on.

**4-62** An extra winding on pulse transformer A1T1 (terminals 3 and 4) provides an output pulse whenever the crowbar is fired. Conversely, an input pulse applied to this same winding can be used to fire the crowbar from an external source. As described in Section III, this feature is useful for creating a crowbar slaving arrangement for the crowbar circuits in more than one supply. With the crowbars slaved together, all of the circuits become activated when any one of the crowbars is tripped.

#### **4-63 Reference Supplies**

**4-64** This unit contains three separate reference supplies that employ regulation techniques similar to that of the main supply. The three supplies all receive their raw (unregulated) dc from a common full-wave rectifier (CR1, 2, 4, 5) and filter (C27, 28).

**4-65** Integrated circuit chip A1U6 provides +5V, with respect to  common, for the logic circuits in the main supply. An input comparator compares the +5V output at the junction of R70, R73 with an adjustable reference voltage. If a difference exists, an error voltage is applied to the series regulator in the correct amplitude and phase to maintain the +5V output constant. Potentiometer R7 is factory adjusted to obtain the output of +5V ±20mV.

**4-66** The remaining two reference supplies (+9V and -9V) are similar in operation to the +5V supply. Note that each of these two supplies contains a Zener diode to provide additional reference voltages of ±6.2Vdc.

#### **4-67 Meter Circuit**

**4-68** The front panel voltmeter and ammeter provide continuous indications of output voltage and current. For isolation purposes, each meter has an input buffer stage

(A1U2) having a unity voltage gain. Note that the output from the current buffer (which represents the output current) is also fed back to the tap selection control logic. Potentiometer R116 and R111 permit calibration of the voltmeter and ammeter, respectively.

**4-69** The voltmeter is essentially connected across the output terminals of the supply (between -OUT and +S<sub>1</sub>). It is in series with resistors R113 and R114 and is shunted by R115 and R116.

**4-70** The ammeter, together with its series components, is effectively connected across the current monitoring resistance, A2R3, R4. As mentioned previously, the voltage drop across the monitoring resistors varies in proportion to the output current.

#### **4-71 Special Purpose Components**

**4-72** The supply contains several special purpose components which either protect the supply, or improve its performance. One of these components is diode A2CR11 which is connected across the output terminals of the supply and prevents internal damage from reverse voltages that might be applied across the supply. This could occur, for example, during Auto-Series operation if one supply is turned on before the other.

**4-73** Capacitors C1 and A2C4, connected across the front and rear terminals, respectively, are for spike suppression. Protection diodes A2CR9, CR10 limit the output of the supply if the shorting straps between the output terminals and sensing terminals (+S and -S) are inadvertently removed.

**4-74** An RC network (A2R2, C2) is connected between the + and +S terminals to prevent instability of the feedback loop during remote sensing applications. Capacitor A2C2 does not influence circuit operation normally because it is shorted-out by the strap between the + and +S terminals. However, during remote sensing operation the strap is removed at the terminals and A2C2 compensates for the inductance of long load and sense leads by acting as an ac short at the frequencies of interest.

**4-75** The series regulator also contains various protection components such as a thermal switch, fuses, etc. These components are fully described in the series regulator portion of this section.

## SECTION V MAINTENANCE

### 5-1 INTRODUCTION

5-2 Upon receipt of the power supply, the performance test (paragraph 5-5) can be made. This test is suitable for incoming inspection. If a fault is detected in the power supply while making the performance test or during normal operation, proceed to the troubleshooting procedures.

After troubleshooting and repair (paragraph 5-53) perform any necessary adjustments and calibrations (paragraph 5-77). Before returning the power supply to normal operation,

repeat the applicable portions of the performance test to ensure that the fault has been properly corrected and that no other faults exist. Before performing any maintenance checks, turn on the power supply and allow a half-hour warm-up.

### 5-3 TEST EQUIPMENT REQUIRED

5-4 Table 5-1 lists the test equipment required to perform the various procedures described in this section.

Table 5-1. Test Equipment Required

TYPE	REQUIRED CHARACTERISTICS	USE	RECOMMENDED MODEL
Digital Voltmeter	Sensitivity: 100 $\mu$ V full scale (min.) Input Impedance: 10M $\Omega$ (min.)	Measure dc voltages; calibration procedures	HP 3450B
Oscilloscope	Sensitivity and bandwidth: 100 $\mu$ V/cm and 400kHz for all measurements except noise spike; 5mV sensitivity and 20MHz bandwidth for noise spike measurement.	Measure ripple; display transient recovery waveform; measure noise spikes.	HP 180C with 1821A time base and 1806A vertical plug-in; 1803A plug-in for spike measurement.
Variable Voltage Transformer	Voltage range: See paragraph 2-20. Output current: 200% (min.) of supply input current listed in paragraph 2-20.	Vary ac input for line regulation measurement.	---
Digital or Analog Multimeter		Measure ac and dc voltages, resistance.	HP 3490A or HP 427A.
Repetitive Load Switch	Switching rate: 50-60Hz. Rise time: 2 $\mu$ sec.	Measure transient recovery time.	See Figure 5-4.
Resistive Load	Values: See Figures 5-1, 5-4, and 5-7. Tolerance: 5% (Two required if rheostat is used.)	Power supply load resistor (Rheostat or fixed resistors).	James G. Biddle non-inductive Rheostat, 411KN56.
Current Monitoring Resistor	Value: See Figure 5-7. Accuracy: 1% minimum	Measure output current; calibrate ammeter.	Simpson Portable Shunt, Model 06704. 50mV at 10A.
Terminating Resistors	Value: 50 ohms, 1/2 watt, $\pm$ 5% non-inductive. (Four required.)	Noise spike measurement.	---
Blocking Capacitors	Value: 0.01 $\mu$ F, 100Vdc. (Two required.)	Noise spike measurement.	---

## 5-5 PERFORMANCE TEST

5-6 The following test can be used as an incoming inspection check and appropriate portions of the test can be repeated to check the operation of the instrument after repairs. The tests are performed using the specified nominal input voltage for the unit. If the correct result is not obtained for a particular check, proceed to troubleshooting (Paragraph 5-53).

## 5-7 Measurement Techniques

5-8 All specifications should be measured at the rear terminals of the power supply. Also, all tests are performed with the supply strapped for local programming and sensing, as shown in Figure 3-2. If the supply is equipped with an HP-IB Interface (Option 001), place the rear panel MODE switch in the local position and check out the power supply first. Then proceed to the checkout procedure in Appendix A, Paragraph A-90, to test the Option 001 components.

5-9 **Selecting A Load Resistor.** Specifications are checked with varying amounts of load resistance connected across the supply. For most of the constant voltage tests, the value of load resistance must be  $12.5\Omega$  to permit operation of the supply at its' maximum rated output voltage (50V) and its' 200W output current of 4A. For the constant current tests, the load resistance must be approximately  $2\Omega$  to permit operation at 10A (the maximum rated output current) and 20V. The wattage rating of the load resistance must be at least equal to the maximum output power of the supply - 200 Watts.

5-10 Either fixed or variable (rheostat type) load resistors can be used. However, a rheostat is very convenient when changing values and for accurately setting the output current of the supply. Table 5-1 lists a rheostat that is adequate for this supply. If fixed load resistors are used, their tolerance must be accounted for when evaluating the test results.

## 5-11 Constant-Voltage Tests

5-12 Connect all of the measuring devices used in the constant voltage performance tests directly to the power supply sensing terminals ( $\pm S$ ). For best accuracy, the sensing terminals must be used rather than the output terminals, since the measuring instruments must be connected to the same pair of terminals to which the feedback amplifier within the power supply is connected. This is particularly important when measuring the regulation, transient response, or ripple of the power supply. A measurement made across the load includes the impedance of the leads to the load and such lead lengths can easily have an impedance several orders of magnitude greater

than the supply impedance (typically 1 milliohm at dc), thus invalidating the measurement.

5-13 To avoid mutual coupling effects, connect each monitoring device to the sensing terminals by a separate pair of leads. Use twisted pairs or shielded two-wire cables to avoid pickup on the measuring leads. Connect the load resistor across the output terminals as close to the supply as possible. When measuring the constant-voltage performance specifications set the current control at least 2% above the output current the supply will draw, since the onset of constant-current operation could cause a drop in output voltage, increased ripple and other performance changes not properly ascribed to the constant-voltage operation of the supply.

5-14 **Rated Voltage and Voltmeter Accuracy.** To check that the supply will furnish its rated output voltage, proceed as follows:

- Connect load resistance and digital voltmeter across rear terminals as shown in Figure 5-1. Set  $R_L$  to maximum resistance, initially.
- Turn CURRENT control fully clockwise.
- Turn on supply and adjust VOLTAGE control until front panel meter indicates exactly maximum rated output voltage (50V).
- Reduce resistance of  $R_L$  until front panel ammeter indicates about 4 Amps (resistance of approximately  $12.5\Omega$ ). Ensure that supply remains in constant voltage mode.
- Digital voltmeter should indicate  $50 \pm 1V$ .

## 5-15 Load Effect (Load Regulation).

Definition: The change  $\Delta E_{OUT}$  in the static value of dc output voltage resulting from a change in load resistance from open circuit to a value which yields maximum rated output current, or vice versa.

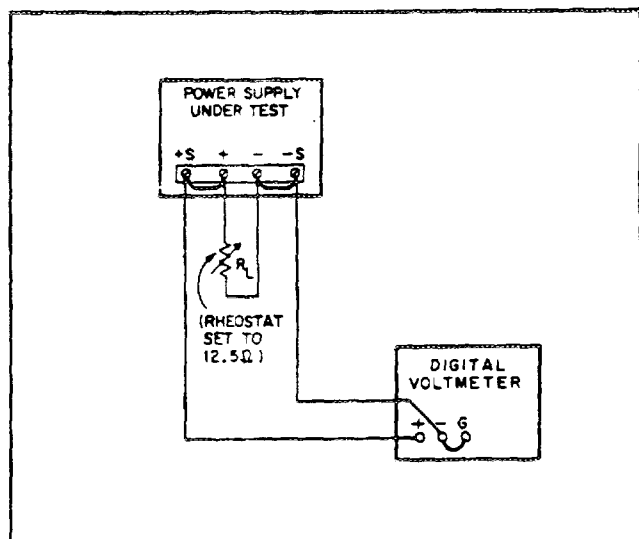

Figure 5-1. Constant-Voltage Test Setup

5-16 To check the constant-voltage load effect, proceed as follows:

- a. Connect test setup shown in Figure 5-1.
- b. Turn CURRENT control fully clockwise.
- c. Turn on supply and adjust VOLTAGE control until digital voltmeter indicates exactly maximum rated output (50V).
- d. If necessary, repeat step d (Paragraph 5-14) to obtain about 4A output current with supply in constant voltage mode.
- e. Disconnect load resistor.
- f. Reading on digital voltmeter should not differ from reading of step c by more than 6mVdc.

5-17 Source Effect (Line Regulation).

Definition: The change  $\Delta E_{OUT}$  in the static value of dc output voltage resulting from a change in ac input voltage over the specified range from low line to high line, or from high line to low line.

5-18 To check the source effect, proceed as follows:

- a. Connect test setup shown in Figure 5-1.
- b. Connect variable autotransformer between input power source and power supply power input.
- c. Adjust autotransformer for low line voltage (Paragraph 2-20).
- d. Turn CURRENT control fully clockwise.
- e. Turn on supply and adjust VOLTAGE control digital voltmeter indicates exactly maximum rated output voltage.
- f. If necessary, repeat step d (Paragraph 5-14) to obtain about 4A output current with supply in constant voltage mode.
- g. Adjust variable autotransformer for high line voltage.
- h. Digital voltmeter reading should not differ from reading of step e by more than 6mVdc.

5-19 PARD (Ripple and Noise).

Definition: The residual ac voltage superimposed on the dc output of a regulated power supply. Ripple and noise measurements may be made at any input ac line voltage combined with any dc output voltage and load current within the supply's rating.

5-20 The amount of ripple and noise present on the power supply output is measured either in terms of its rms or (preferably) peak-to-peak value. The peak-to-peak measurement is particularly important for applications where noise spikes could be detrimental to sensitive loads such as logic circuitry. The rms measurement is not an ideal representation of the noise since fairly high output noise spikes of short duration can be present in the ripple without appreciably increasing the rms value.

5-21 Ripple Measurement Techniques. Figure 5-2A shows an incorrect method of measuring peak-to-peak ripple. Note that a continuous ground loop exists from the third wire of the input power cord to the supply to the third wire of the input power cord to the oscilloscope via the grounded power supply case, the internal jumper connecting the power supply negative output and sensing terminals, the wire between the negative sensing terminal of the power supply and the vertical input of the scope, and the grounded scope case. Any ground current circulation in this loop as a result of the difference in potential  $E_G$  between the two ground points causes an IR drop which is in series with the scope input. This IR drop, normally having a 60Hz line frequency fundamental, plus any pickup on the unshielded leads interconnecting the power supply and scope, appears on the face of the CRT. The magnitude of this resulting noise signal can easily be much greater than the true ripple developed between the plus and minus sensing terminals of the power supply and can completely invalidate the measurement.

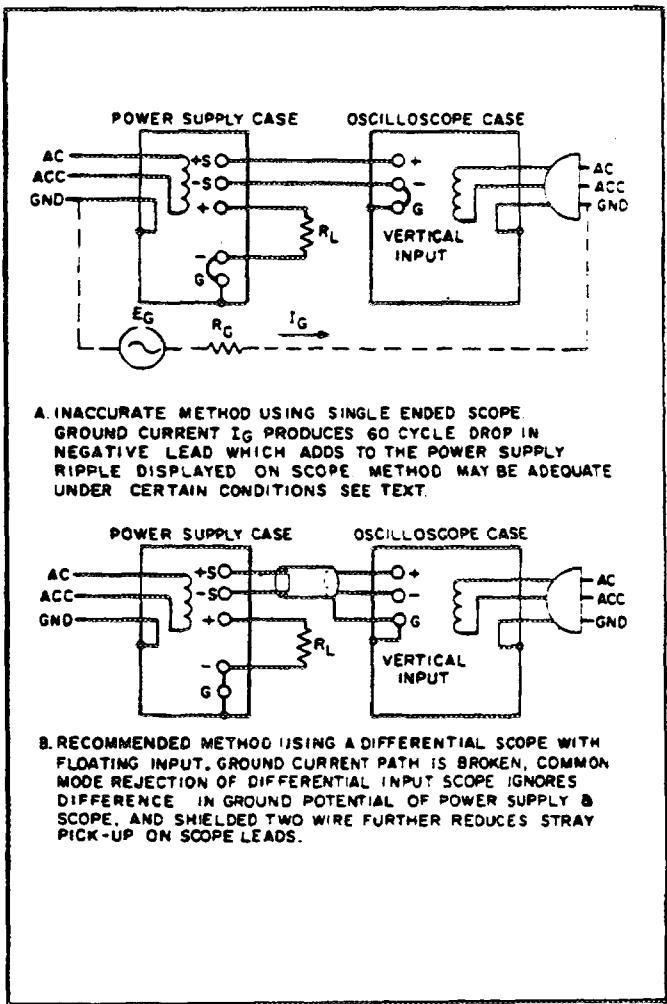

Figure 5-2. Ripple Test Setup

**5-22** The same ground current and pickup problems can exist if an rms voltmeter is substituted for the oscilloscope in Figure 5-2. However, the oscilloscope display, unlike the true-rms meter reading, tells the observer immediately whether the fundamental period of the signal displayed is 8.3 milliseconds (1/120Hz) or 16.7 milliseconds (1/60Hz). Since the fundamental ripple frequency present on the output of an HP supply is 120Hz (due to full-wave rectification), an oscilloscope display showing a 120Hz fundamental component indicates a "clean" measurement setup, while the presence of a 60Hz fundamental usually means that an improved setup will result in a more accurate (and lower) value of measured ripple.

**5-23** Although the method shown in Figure 5-2A is not recommended for ripple measurements, it may prove satisfactory in some instances provided certain precautions are taken. One method of minimizing the effects of ground current flow ( $I_G$ ) is to ensure that both the supply and the test instrument are plugged into the same ac power bus.

**5-24** To minimize pickup, a twisted pair or (preferably) a shielded two-wire cable should be used to connect the sensing terminals of the power supply to the vertical input terminals of the scope. When using a twisted pair, take care that the same wire is connected both to the grounded terminal of the power supply and the grounded input terminal of the oscilloscope. When using shielded two-wire cable, it is essential for the shield to be connected to ground at only one end to prevent any ground current flowing through this shield from inducing a signal in the shielded leads.

**5-25** To verify that the oscilloscope is not displaying ripple that is induced in the leads or picked up from the grounds, short the (+) scope lead to the (-) scope lead at the power supply terminals. The ripple value obtained when the leads are shorted should be subtracted from the indicated ripple measurement.

**5-26** If the foregoing measures are used, the single-ended scope of Figure 5-2A might be adequate to eliminate extraneous ripple components so that a satisfactory measurement can be obtained. However, in stubborn cases or in measurement situations where it is essential that both the power supply case and the oscilloscope case be connected to ground (if both are rack-mounted, for example), it may be necessary to use a differential scope with floating input as shown in Figure 5-2B. If desired, two single-conductor shielded cables may be substituted in place of the shielded two-wire cable with equal success. Because of its common mode rejection, a differential oscilloscope displays only the difference in signal between its two vertical input terminals, thus ignoring the effects of any common mode signal produced by the difference in the ac potential between

the power supply case and scope case. Before using a differential input scope, however, it is imperative that the common mode rejection capability of the scope be verified by shorting together its two input leads at the power supply and observing the trace on the CRT. If this trace is a straight line, then the scope is properly ignoring any common mode signal present. If this trace is not a straight line, then the scope is not rejecting the ground signal and must be realigned in accordance with the manufacturer's instructions so that proper common mode rejection is attained.

**5-27** **Ripple Measurement Procedure.** To check the ripple output, proceed as follows:

- a. Connect oscilloscope or rms voltmeter as shown in Figures 5-2A or 5-2B.
- b. Turn CURRENT control fully clockwise.
- c. Turn on supply and adjust VOLTAGE control and  $R_L$  so that front panel meters indicate 50V and 4A, as in the previous tests.
- d. The observed ripple should be less than 1mV rms.

**5-28** **Noise Spike Measurements.** An instrument of sufficient bandwidth must be used when making a high frequency spike measurement. An oscilloscope with a bandwidth of 20MHz or more is adequate. Measuring noise with an instrument that has insufficient bandwidth may conceal high frequency spikes that could be detrimental to the load.

**5-29** The test setup illustrated in Figure 5-2A is generally not adequate for measuring spikes; a differential oscilloscope is necessary. Furthermore, the measurement technique of Figure 5-2A must be modified as follows if accurate spike measurement is to be achieved:

1. As shown in Figure 5-3, two coax cables must be substituted for the shielded two-wire cable.
2. Impedance matching resistors must be included to eliminate standing waves and cable ringing, and capacitors must be connected to block dc current.
3. The length of the test leads outside the coax is critical and must be kept as short as possible. The blocking capacitor and impedance matching resistor should be connected directly from the inner conductor of the cable to the power supply sensing terminal.
4. Notice that the shields at the power supply end of the two coax cables are not connected to the power supply ground since such a connection would give rise to a ground current path through the coax shield and result in an erroneous measurement.
5. Since the impedance matching resistors constitute a 2-to-1 attenuator, the noise spikes observed on the oscilloscope should be less than 5mV p-p instead of 10mV p-p.

**5-30** The circuit of Figure 5-3 can also be used for the normal measurement of low frequency ripple. Simply



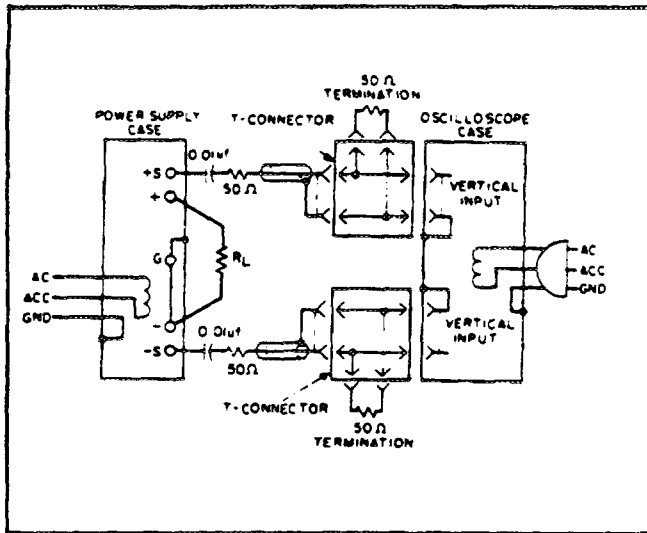

Figure 5-3. Noise Spike Measurement Test Setup

remove the four terminating resistors and the blocking capacitors and substitute a higher gain vertical plug-in for the wide-band plug-in required for spike measurements. Notice that with these changes, Figure 5-3 becomes a two-cable version of Figure 5-2B.

### 5-31 Load Transient Recovery Time.

**Definition:** The time "X" for output voltage recovery to within "Y" millivolts of the nominal output voltage following a "Z" amp step change in load current, where: "Y" is specified as 15mV; the nominal output voltage is defined as the dc level halfway between the static output voltage before and after the imposed load change; and "Z" is the specified load current change of from 50% to 100% (or vice-versa) of maximum current rating.

**5-32 Measurement Techniques.** Care must be taken in switching the load resistance on and off. A hand-operated switch in series with the load is not adequate since the resulting one-shot displays are difficult to observe on most oscilloscopes and the arc energy occurring during switching completely masks the display with a noise burst. Transistor load switching devices are expensive if reasonably rapid load current changes are to be achieved.

**5-33** We suggest that a mercury-wetted relay connected in the load switching circuit shown in Figure 5-4 be used for loading and unloading the supply. When this load switch is connected to a 60Hz ac input, the mercury-wetted relay opens and closes 60 times per second. The 25k control adjusts the duty cycle of the load current switching to reduce jitter in the oscilloscope display. This relay may also be used with a 50Hz ac input. The load resistance shown in Figure 5-4 is the minimum resistance that can be used without damaging the mercury-wetted relay contacts.

**5-34 Measurement Procedure.** To check the load transient recovery time, proceed as follows:

- Connect load resistor  $R_{L1}$  (Figure 5-4) across output of supply. Do not connect  $R_{L2}$  and load switch at this time.
- Turn CURRENT control fully clockwise and adjust VOLTAGE control for 20V on front panel meter.
- Next, set  $R_{L1}$  for approximately  $4\Omega$  (5A on front panel ammeter). Ensure that supply operates in constant voltage mode.
- Turn off supply and connect  $R_{L2}$ , in parallel with  $R_{L1}$ . Do not connect load switch yet.
- Turn on supply and set  $R_{L2}$  for approximately  $4\Omega$  ( $2\Omega$  total resistance across supply) and ensure that supply provides 20V, 10A in the constant voltage mode.
- Turn off supply and connect load switch and load resistors as indicated in Figure 5-4.
- Turn on supply and close line switch on repetitive load switch setup.
- Set oscilloscope for internal sync and lock on either the positive or negative load transient spike.
- Set vertical input of oscilloscope for ac coupling so that small dc level changes in power supply output voltage will not cause display to shift.
- Adjust the vertical centering on the scope so that the tail ends of the no-load and full-load waveforms are symmetrically displaced about the horizontal centerline of the oscilloscope. This centerline now represents the nominal output voltage defined in the specification.

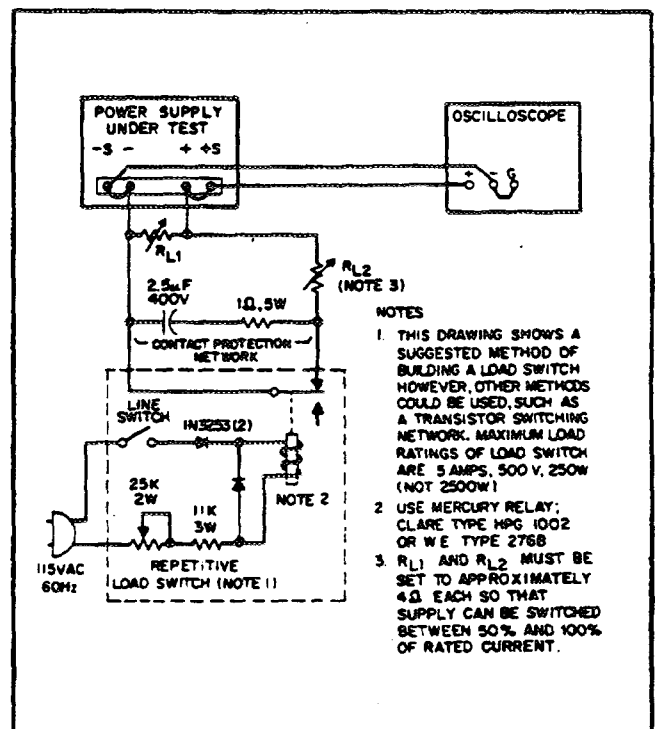

Figure 5-4. Load Transient Recovery Time, Test Setup

k. Adjust the horizontal positioning control so that the trace starts at a major graticule division. This point then represents time zero.

l. Increase the sweep rate so that a single transient spike can be examined in detail.

m. Adjust the sync controls separately for the positive and negative-going transients so that not only the recovery waveshape but also as much as possible of the rise time of the transient is displayed.

n. Starting from the major graticule division representing time zero, count to the right  $100\mu\text{sec}$  and vertically  $15\text{mV}$ . Recovery should be within these tolerances as illustrated in Figure 5-5.

### 5-35 Temperature Coefficient.

**Definition:** The change in output voltage per degree Celsius change in ambient temperature measured while ac line voltage, output voltage setting, and load resistance are all held constant.

**5-36** The temperature coefficient of a power supply is measured by placing the power supply in an oven and varying it over any temperature span within its rating. (Most HP power supplies are rated for operation from  $0^{\circ}\text{C}$  to  $55^{\circ}\text{C}$ .) The power supply temperature must be allowed to stabilize for a sufficient time at each measurement temperature.

**5-37** The temperature coefficient given in the specifications is the maximum temperature-dependent output voltage change which will result over any one-degree interval. The digital voltmeter used to measure the supply's output voltage change should be placed outside the oven and should have a long-term stability adequate to insure that its drift will not affect the overall measurement accuracy.

**5-38** To check the temperature coefficient, proceed as follows:

- Connect load resistance and digital voltmeter as illustrated in Figure 5-1.
- Turn CURRENT control fully clockwise.
- Repeat steps c and d of Paragraph 5-14 so that supply provides  $50\text{V}$  at  $4\text{A}$  in the constant voltage mode.
- Place power supply in temperature-controlled oven (digital voltmeter remains outside oven). Set temperature to  $30^{\circ}\text{C}$  and allow 30 minutes warm-up.
- Record digital voltmeter reading.
- Raise temperature to  $40^{\circ}\text{C}$  and allow 30 minutes warm-up.
- Observe digital voltmeter reading. Difference in voltage reading between steps (e) and (g) should be less than  $102\text{mVdc}$ .

### 5-39 Drift (Stability):

**Definition:** The change in output voltage for the first

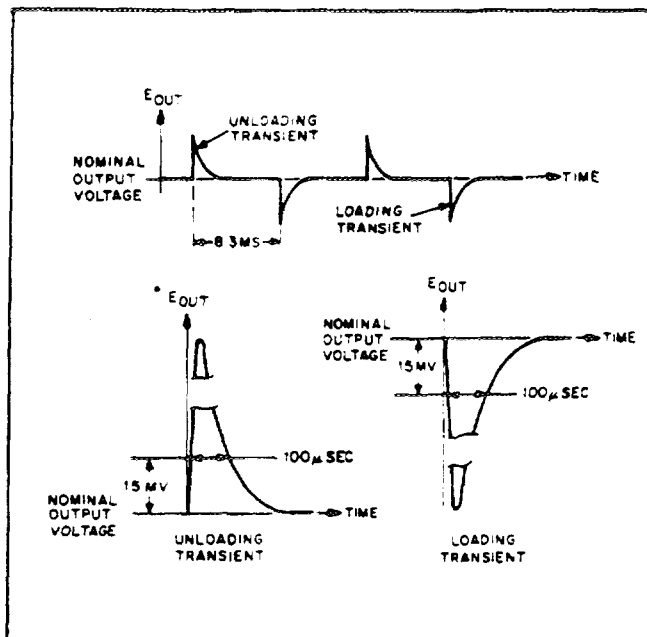

**Figure 5-5.** Load Transient Recovery Waveforms

eight hours following a 30-minute warm-up period. During the interval of measurement, input line voltage, load resistance, and ambient temperature, are all held constant.

**5-40** This measurement is made by monitoring the output of the power supply on a digital voltmeter over the stated measurement interval. A strip chart recorder can be used to provide a permanent record. Place a thermometer near the supply to verify that the ambient temperature remains constant during the period of measurement. The supply should be located away from any source of stray air currents. If possible, place the supply in an oven and hold it at a constant temperature. Take care that the measuring instrument has an eight-hour stability at least an order of magnitude better than the stability specification of the power supply being tested. Typically, a supply will drift less over the eight-hour measurement interval than during the half-hour warm-up period.

**5-41** To check the output stability, proceed as follows:

- Check load resistance and digital voltmeter as illustrated in Figure 5-1.
- Turn CURRENT control fully clockwise.
- Repeat steps c and d of Paragraph 5-14 so that supply provides  $50\text{V}$  at  $4\text{A}$  in the constant voltage mode.
- Allow 30 minutes warm-up, then record digital voltmeter reading.
- After 8 hours, digital voltmeter reading should not differ from the step (d) reading by more than  $26\text{mVdc}$ .

### 5-42 CONSTANT-CURRENT TESTS

**5-43** The instruments, methods, and precautions for the proper measurement of constant-current power supply

characteristics are for the most part identical to those already described for the measurement of constant-voltage characteristics. There are, however, two main differences: first, the power supply performance will be checked between short circuit and full load rather than open circuit and full load. Second, a current monitoring resistor is inserted between the output of the power supply and the load resistance.

**5-44** The total resistance of the series combination (load and monitoring resistance) should be equal to  $2\Omega$  so that the supply provides 10A (maximum rated current) at 20V. For all output current measurements, the current sampling (monitoring) resistor must be connected as a four-terminal device in the same manner as a meter shunt would be. The load current is fed to the extremes of the wire leading to the resistor while the monitoring terminals are located as close as possible to the resistance element itself (see Figure 5-6). A current sampling resistor should have low noise, low temperature coefficient (less than  $30\text{ppm}/^\circ\text{C}$ ) and should be used at no more than 5% of its rated power so that its temperature rise will be minimized.

**5-45 Current Output and Ammeter Accuracy.** To check that the supply will furnish its rated output current, proceed as follows:

- Connect test setup shown in Figure 5-7. Set  $R_{L1}$  and  $R_{L2}$  to maximum resistance.
- Turn VOLTAGE control fully clockwise.
- Turn on supply and adjust CURRENT control until front panel ammeter indicates maximum rated output current (10A).
- Reduce resistance of  $R_{L1}$  and  $R_{L2}$  until front panel voltmeter indicates about 20V (total load resistance of approximately  $2\Omega$ ). Ensure that supply remains in constant current mode.
- Digital voltmeter should indicate  $50 \pm 1\text{mVdc}$ .

**5-46 Load Effect (Load Regulation).**

**Definition:** The change  $\Delta I_{OUT}$  in the static value of the dc output current resulting from a change in load resistance from short circuit to a value which yields rated output voltage, or vice versa.

**5-47** To check the constant-current load effect proceed as follows:

- Connect test setup shown in Figure 5-7.
- Turn VOLTAGE control fully clockwise.
- Turn on supply and adjust CURRENT control until front panel ammeter indicates exactly maximum rated output current (10A).
- If necessary, repeat step d (Paragraph 5-45) to obtain approximately 20V output with supply in constant current mode (10A output).
- Read and record voltage on digital voltmeter.

f. Short circuit load resistors ( $R_L$ ) by closing switch S1.

g. Digital voltmeter reading should not differ from reading of step e by more than  $10\mu\text{Vdc}$ .

**5-48 Source Effect (Line Regulation).**

**Definition:** The change  $\Delta I_{OUT}$  in the static value of dc output current resulting from a change in ac input voltage over the specified range from low line to high line or from high line to low line.

**5-49** To check source effect, proceed as follows:

- Connect test setup shown in Figure 5-7.
- Connect variable autotransformer between input power source and power supply power input.
- Adjust autotransformer for low line input voltage (Paragraph 2-20).
- Turn VOLTAGE control fully clockwise.
- Turn on supply and adjust CURRENT control until front panel ammeter reads exactly maximum rated output current (10 Amperes).

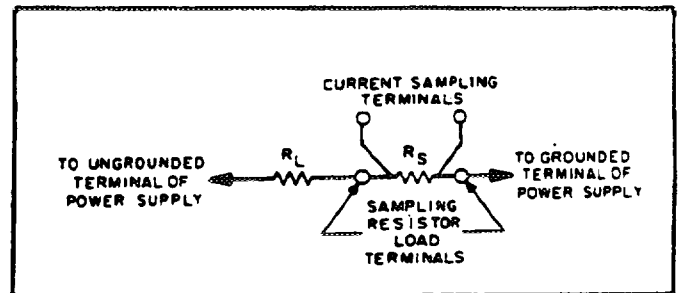

Figure 5-6. Current Sampling Resistor Connections

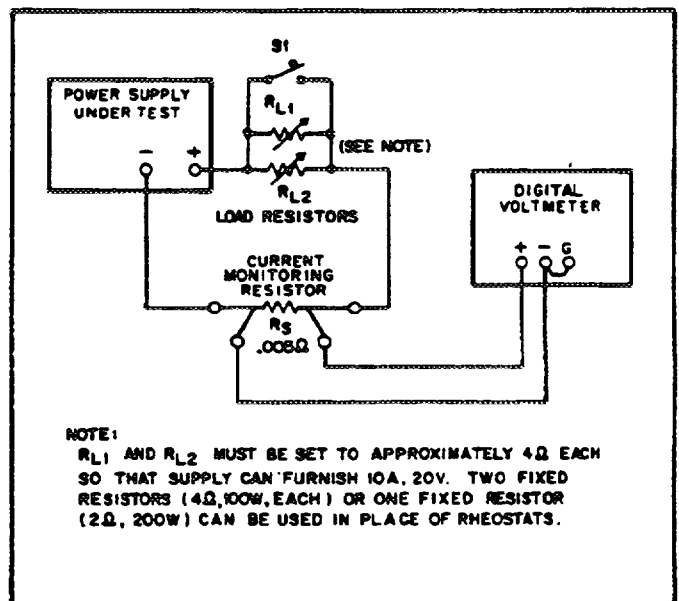

Figure 5-7. Constant Current Test Setup

f. If necessary repeat step d (Paragraph 5-45) to obtain approximately 20V output with supply in constant current mode (10A output).

g. Read and record voltage indicated on digital voltmeter.

h. Adjust autotransformer for high line.

i. Digital voltmeter reading should not differ from reading recorded in step (g) by more than  $10\mu\text{Vdc}$ .

### 5-50 PARD (Ripple and Noise).

**Definition:** The residual ac current superimposed on the dc output of a regulated power supply. Ripple and noise measurement may be made at any input ac line voltage combined with any dc output voltage and load current within the supply's rating.

5-51 Most of the instructions pertaining to the ground loop and pickup problems associated with constant-voltage ripple and noise measurement also apply to the measurement of constant-current ripple and noise. Figure 5-8 illustrates the most important precautions to be observed when measuring the ripple and noise of a constant-current supply. The presence of a 120Hz waveform on the oscilloscope normally indicates a correct measurement method. A waveshape having 60Hz as its fundamental component usually indicates an incorrect measurement setup.

5-52 To check the ripple and noise, proceed as follows:

- Connect oscilloscope or rms voltmeter as shown in Figure 5-8A or 5-8B.
- Rotate VOLTAGE control fully clockwise.
- Turn on supply and adjust CURRENT control and  $R_L$  so that front panel meters indicate 10A and approximately 20V as in the previous constant current tests.
- The observed ripple and noise should be less than  $25\mu\text{Vrms}$ .

## 5-53 TROUBLESHOOTING

5-54 Before attempting to troubleshoot this instrument, ensure that the fault is with the instrument itself and not with an associated circuit. The performance test enables this to be determined without having to remove the covers from the supply.

5-55 A good understanding of the principles of operation is a helpful aid in troubleshooting, and it is recommended that the reader review Section IV of the manual before attempting to troubleshoot the unit in detail. Once the principles of operation are understood, refer to the following paragraphs in sequential order.

5-56 The schematic diagram (Figure 7-9) contains normal voltage readings associated with some of the test points. Section VII also includes waveforms for some of the key test

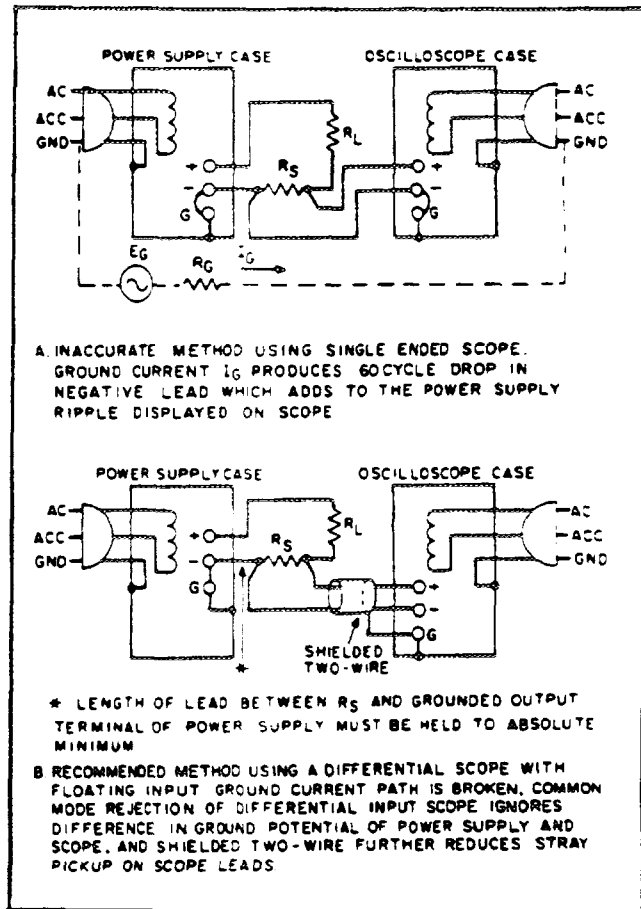

Figure 5-8. Constant Current Ripple and Noise Test Setup

points in the control logic as well as component location diagrams to help the user locate the supply's components and test points. Most of the test points used for troubleshooting the supply are located at the A1 control board test "fingers" which are readily accessible and clearly identified on the board (see Figures 7-2 and 7-3).

5-57 If a component is found to be defective, replace it and re-conduct the performance test. When a component is replaced, refer to the repair and adjustment portions of this section. It may be necessary to perform one or more of the adjustment procedures after a component is replaced.

### 5-58 Initial Troubleshooting Procedures

5-59 If a trouble occurs, follow the below steps in sequence:

- Check for obvious troubles such as a defective power cord, an input power failure, or a defective meter.
- Check line fuse in rear power module. If blown, ensure that power module board is positioned to match input line voltage. Also, check the following for shorts: U1-U2, A2CR1, 2, 4, and 5, A1C27-28, and A3C4-C5, or B1.

(3) In almost all cases, the trouble can be caused by an incorrect dc bias or reference voltages; thus, it is necessary to check the voltages (Paragraph 5-60) before proceeding.

**5-60 Troubleshooting Test Setup.** Before continuing with troubleshooting, proceed as follows:

- a. Turn off supply and disconnect all loads.
- b. Connect a 100Ω (4 Watt) load resistor across rear output terminals.
- c. Turn VOLTAGE control to mid-range (five turns), CURRENT control to minimum (fully CCW) and OVERVOLTAGE control to maximum (fully CW).
- d. Turn on power and check reference voltages as indicated in Table 5-2. When the reference voltages are correct, proceed to Paragraph 5-61.

**5-61 Front Panel Meter and Indicator Verification.**

Because the front panel voltmeter and ammeter are used during succeeding troubleshooting procedures, their operation must be verified before proceeding. To check the meters,

connect an external voltmeter and ammeter to the output terminals and compare their readings with those of the front panel meters. If the front panel meters are operating properly, they can be used during troubleshooting. If not, use the external meters until they can be repaired.

**5-62** The OVERRANGE indicator (LED) is also used to provide isolation symptoms during troubleshooting procedures. To verify proper operation of this indicator, turn the OVERVOLTAGE control counterclockwise until the unit crowbars (output voltage falls to near zero). The OVERRANGE indicator should light. If it does not, check A1VR3 for open and the indicator itself. Once this indicator is working properly, proceed to the overall isolation procedures in Figure 5-9.

**5-63 Overall Trouble Isolation**

**5-64** After the reference voltage circuit has been eliminated as a trouble source and operation of the front panel meters has been verified, proceed to the isolation procedures of Figure 5-9.

**Table 5-2. Reference Voltage Check**  
(All voltages measured at A1 board test fingers. See Figure 7-3).

STEP	METER COMMON	METER POSITIVE	NORMAL VDC	CHECK AND PROBABLE CAUSE
1	+S	+9	9.2 ± 0.64	Check for presence of +18V Unregulated. If absent, check fusible links on A2 board and for open A2CR2, 3 or 5, T1 or power module. If present, check for defective A1VR6, Q8 and U9. Also check for shorted A1U1-U2.
2	+S	-9	9.2 ± 0.64	Check for presence of -18V Unregulated. If absent, check A2CR1, 4 for open. If present, check A1VR5, U8. Also check for shorted A1U1-U2.
3	INBD	+5	5 ± 0.02	Check A1U6 and associated components. If ok, check for shorted IC (A1U3-U5).

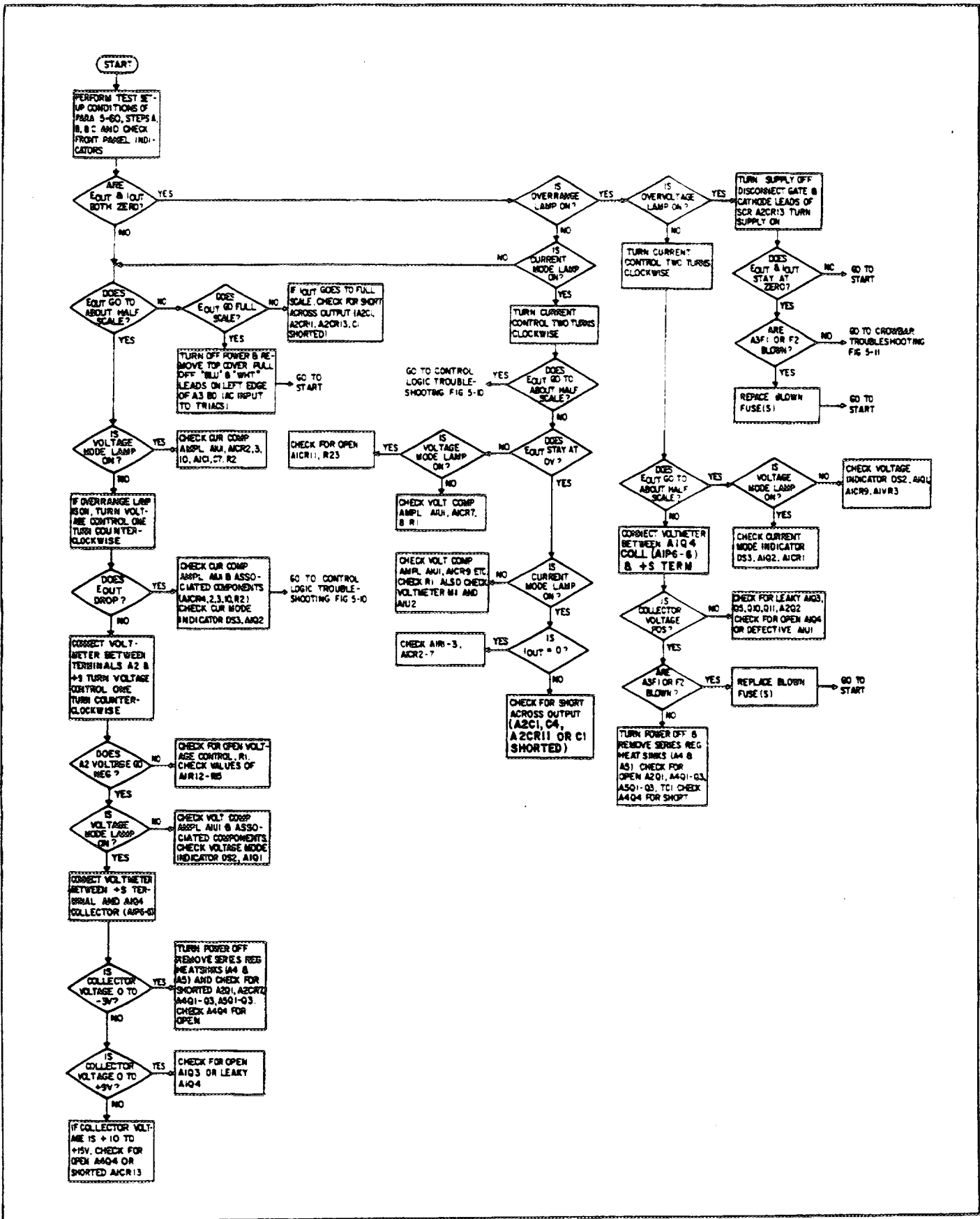

Figure 5-9. Overall Trouble Isolation

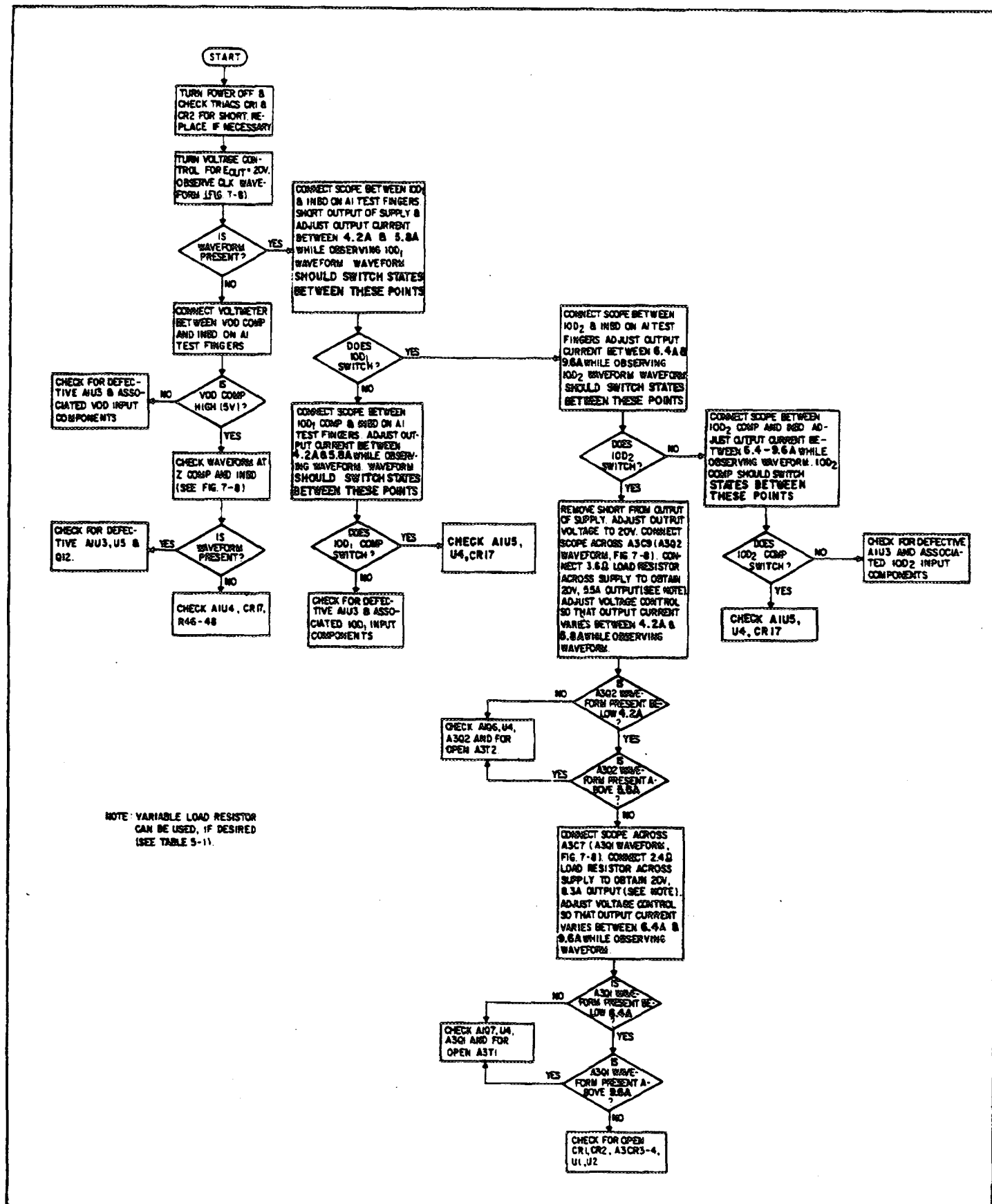

Figure 5-10. Control Logic Troubleshooting

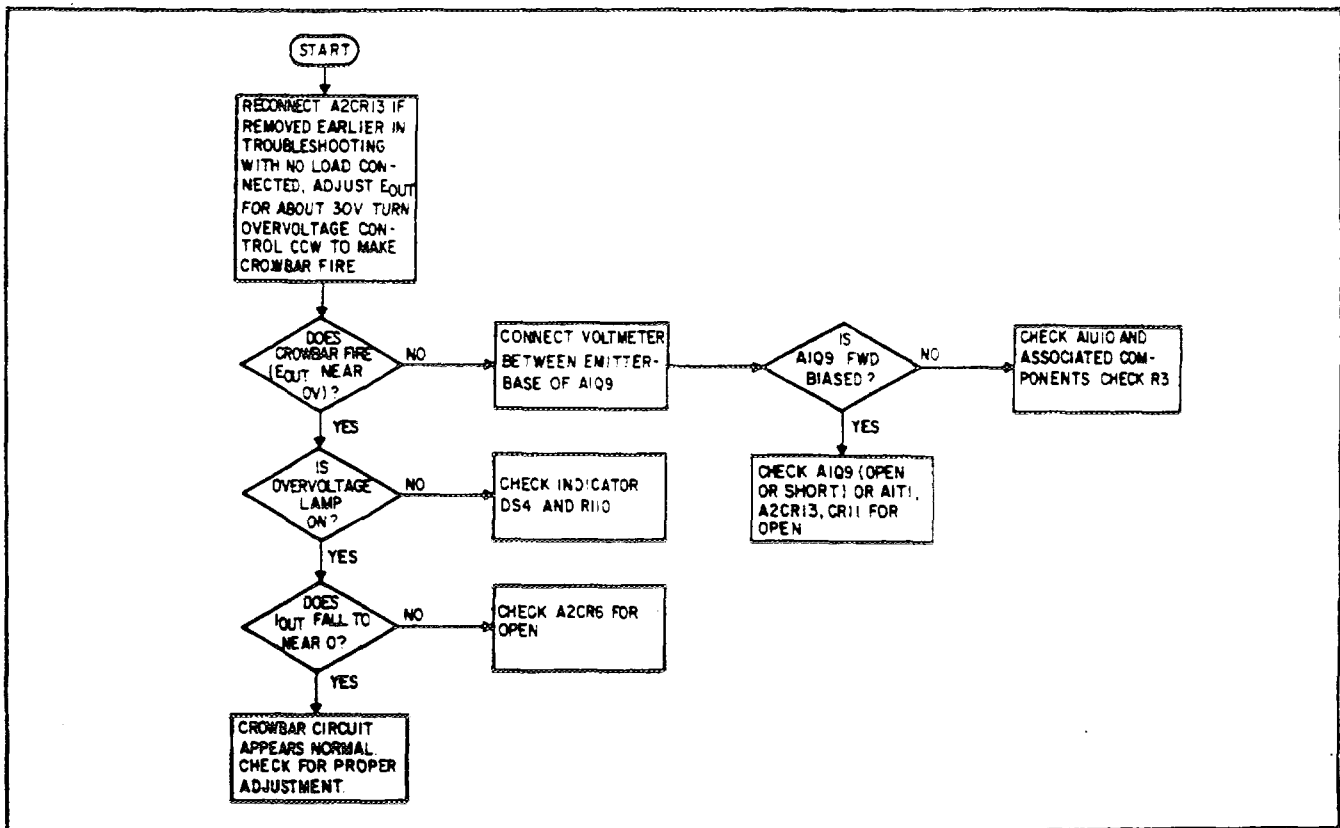

Figure 5-11. Crowbar Circuit Troubleshooting

## 5-65 REPAIR AND REPLACEMENT

### 5-66 Outside Cover Removal

5-67 To remove the top-side cover, proceed as follows:

- a. Remove one screw in carrying handle at top-rear of cover.
- b. Slide cover toward rear of unit, then lift clear when front of cover clears front panel casting.

5-68 To remove bottom cover, proceed as follows:

- a. Turn supply upside down.
- b. Remove one screw at rear-center of cover.
- c. Slide cover toward rear of unit until completely free.

### 5-69 A1 Control Board Removal

5-70 To remove the A1 board, proceed as follows:

- a. Remove bottom cover.
- b. With unit upside down, remove seven 6-32 screws along edges of board and two screws near center of board.
- c. Disconnect A1 from interconnect board A2 by lifting A1 straight up.

### 5-71 Front Panel Removal

5-72 To remove the front panel assembly, proceed as follows:

- a. Remove snap-out trim along top and bottom of front panel casting.
- b. Remove two 6-32 screws now exposed on top and bottom of casting.
- c. Pull front panel assembly forward and away from unit.

### 5-73 Top and Bottom Heat Sink Removal

5-74 In order to gain access to the series regulating and driver transistors the A4 and A5 heat sink boards must be removed from the unit, as follows:

- a. Remove top and bottom covers.
- b. Remove A1 control board.
- c. With unit upside down, remove three 6-32 screws in bottom frame (underneath A1 board) that fasten the three heat sink insulating standoffs.
- d. Turn unit rightside up and pull heat sink away from interconnect board A2 to disconnect A4 and A5 connectors.
- e. Lift heat sinks out of unit.



## 5-75 Replacement Parts

5-76 Section VI of this manual contains a list of replaceable parts. If the part to be replaced does not have a standard manufacturer's part number, it is a special part and must be obtained directly from Hewlett-Packard. After replacing a semiconductor device, refer to Table 5-3 for checks and adjustments that may be necessary.

## 5-77 ADJUSTMENT AND CALIBRATION

5-78 Adjustment and calibration may be required after performance testing, troubleshooting, or repair and replacement. Perform only those adjustments that affect the operation of the faulty circuit. If more than one adjustment will be made, they should be performed in the order in which they appear in the following paragraphs.

### 5-79 Meter Zero Adjustment

5-80 The meter pointer must rest on the zero calibration mark on the meter scale when the instrument is at normal operating temperature, resting in its normal operating position, and turned off. To zero the meter, proceed as follows:

- a. Connect load resistor of value shown in Figure 5-1, turn on instrument, and allow it to come up to normal operating temperature (about 30 minutes).

- b. Turn instrument off and wait two minutes for power supply capacitors to discharge completely.

- c. Insert pointed object (pen point or awl) into small indentation near top of round black plastic disc located directly below meter face.

- d. Rotate plastic disc clockwise until meter reads zero, then rotate counterclockwise slightly in order to free adjustment screw from meter suspension. Pointer should not move during latter part of adjustment.

### 5-81 Voltmeter Calibration

5-82 To calibrate the voltmeter, place unit in the upright position and proceed as follows:

- a. Connect digital voltmeter across plus and minus output terminals of supply, observing correct polarity.

- b. Turn on supply and adjust VOLTAGE control until digital voltmeter reads exactly the maximum rated output voltage (50V).

- c. Adjust A1R116 until front panel voltmeter also indicates exactly the maximum rated output voltage.

### 5-83 Ammeter Calibration

5-84 To calibrate the ammeter, place unit in upright position and proceed as follows:

- a. Connect test setup shown in Figure 5-7.

- b. Turn VOLTAGE control fully clockwise.

Table 5-3. Checks and Adjustments Required After Component Replacement

REFERENCE	FUNCTION OR CIRCUIT	CHECK	ADJUST
A1U2, M1 and associated components.	Voltmeter	Voltmeter calibration.	A1R116
A1U2, M2 and associated components	Ammeter	Ammeter calibration	A1R111
A1U1, R12-R15, VR6, R1	CV comparison amplifier	Constant voltage programming accuracy	A1R15
A1U1, R2, VR5, R2.	CC comparison amplifier	Constant current programming accuracy	A1R1, R6
A1U6 and associated components	+5V reference supply	+5V $\pm$ 20mVdc	A1R71
A1U3, U4 and associated input components	Control logic decision comparators	IOD <sub>1</sub> and IOD <sub>2</sub>	A1R71, 53, 58

c. Turn on supply and adjust CURRENT control and  $R_L$  (rheostats) so that supply is in constant current mode and digital voltmeter reads 50mVdc.

d. Adjust A1R111 until front panel ammeter indicates exactly maximum rated output current (10A).

### 5-85 Constant-Voltage Programming Accuracy

5-86 The constant voltage programming accuracy adjustment (at maximum output voltage) is described below. Note that there is no adjustment for 0 volt programming accuracy in this supply. (This adjustment can be made externally, if required — refer to Section III). To adjust the constant voltage, full scale accuracy, proceed as follows:

- Connect digital voltmeter between +S and -S terminals at rear.
- Set VOLTAGE and CURRENT controls to maximum (fully CW).
- Turn on supply, no load connected, and adjust A1R15 for 50.5Vdc on the digital voltmeter.

### 5-87 Constant-Current Programming Accuracy

5-88 Maximum Output Current. To calibrate the constant current programming accuracy at maximum output current, proceed as follows:

- Connect test setup shown on Figure 5-7. Load resistance is shorted-out for this adjustment.
- Turn CURRENT control fully clockwise and turn on supply.
- Adjust A1R1 for 10.1 Ampere output current (50.5mVdc indication on digital voltmeter).
- Perform zero output current adjustment, next.

5-89 Zero Output Current. To calibrate the zero current programming accuracy, proceed as follows:

- Connect test setup shown on Figure 5-7.
- Turn VOLTAGE control fully clockwise.
- Turn CURRENT control fully CCW (minimum).
- Adjust A1R6 for  $0 \pm 50\mu\text{Vdc}$  indication on digital voltmeter.
- Repeat maximum output current adjustment, steps a through c, and readjust if necessary.

### 5-90 +5V Reference Voltage Adjustment

5-91 This adjustment should be performed, if any component in the +5V reference supply is replaced. Proceed as follows:

- Turn on supply, and with no load connected, set VOLTAGE control to 50V.
- Connect digital voltmeter between +5V and INBD (TP7 and 5) test fingers on A1 control board (Figure 7-3).

c. Adjust A1R71 (circuit side of A1 board) for  $5 \pm 0.02\text{Vdc}$  indication on digital voltmeter.

### 5-92 Calibration of Output Current Decision Points

5-93 The following adjustments set the  $\text{IOD}_1$  and  $\text{IOD}_2$  decision points (shown on Figure 4-3) which in turn establish the 200 Watt operating curve. These adjustments are performed at the factory and should not require readjustment unless certain logic circuit components are replaced (see Table 5-3) or the IOD adjustment potentiometer settings shift due to vibration, etc. Both IOD adjustments must be done together.

#### NOTE

*Before adjusting the IOD decision points, the +5Vdc reference must be checked and adjusted, if necessary.*

5-94  $\text{IOD}_1$  Adjustment. To adjust the  $\text{IOD}_1$  decision point, proceed as follows:

- Connect external current monitoring resistor and digital voltmeter across output terminals as shown in Figure 5-7 (load resistors  $R_{L1}$  and  $R_{L2}$  are not required for this adjustment).
- Connect dc coupled oscilloscope between  $\text{IOD}_1$  and INBD (  ) test fingers on A1 control board.
- Connect variable auto transformer between input power source and power supply ac input.
- Adjust autotransformer to nominal line (115Vac for 120Vac input).
- Turn VOLTAGE control fully CW.
- Turn on supply and adjust CURRENT control for exactly 4.9A output current (24.5mVdc indication on digital voltmeter).
- Adjust A1R53 (circuit side of A1 board) to obtain a high  $\text{IOD}_1$  logic level (approximately +4.5V) on scope. Next, turn A1R53 in opposite direction until logic level switches from high to low (approximately 0.5V) on oscilloscope. (R53 must be set exactly at switching point).
- Adjust CURRENT control for 5.3A output current (26.5mVdc on digital voltmeter).
- Observe  $\text{IOD}_1$  logic level on oscilloscope. It should now be high (4.5V). If logic level is still low, steps f through i must be repeated.

5-95  $\text{IOD}_2$  Adjustment. To adjust the  $\text{IOD}_2$  decision point proceed as follows:

- Repeat steps a through e of the preceding adjustment except connect oscilloscope between  $\text{IOD}_2$  and INBD test fingers on A1 board.

b. Adjust CURRENT control for exactly 7.5A output current (37.5mVdc on digital voltmeter).

c. Adjust A1R58 to obtain high IOD<sub>2</sub> logic level (+4.5V) on scope. Turn A1R58 in opposite direction until logic level switches from high to low (0.5V) on scope. (R58 must be set exactly at switching point.)

d. Adjust CURRENT control for 8.1A output current (40.5mVdc on digital voltmeter).

e. Observe IOD<sub>2</sub> logic level on scope. It should now be high (about 4.5V). If logic level is still low, repeat steps b through e.



## SECTION VI REPLACEABLE PARTS

### 6-1 INTRODUCTION

6-2 This section contains information for ordering replacement parts. Table 6-4 lists parts in alpha-numeric order by reference designators and provides the following information:

- a. Reference Designators. Refer to Table 6-1.
  - b. Description. Refer to Table 6-2 for abbreviations.
  - c. Total Quantity (TQ). Given only the first time the part number is listed except in instruments containing many sub-modular assemblies, in which case the TQ appears the first time the part number is listed in each assembly.
  - d. Manufacturer's Part Number or Type.
  - e. Manufacturer's Federal Supply Code Number.
- Refer to Table 6-3 for manufacturer's name and address.
- f. Hewlett-Packard Part Number.
  - g. Recommended Spare Parts Quantity (RS) for complete maintenance of one instrument during one year of isolated service.
  - h. Parts not identified by a reference designator are listed at the end of Table 6-4 under Mechanical and/or Miscellaneous. The former consists of parts belonging to and grouped by individual assemblies; the latter consists of all parts not immediately associated with an assembly.

### 6-3 ORDERING INFORMATION

6-4 To order a replacement part, address order or inquiry to your local Hewlett-Packard sales office (see lists at rear of this manual for addresses). Specify the following information for each part: Model, complete serial number, and any Option or special modification (J) numbers of the instrument; Hewlett-Packard part number; circuit reference designator; and description. To order a part not listed in Table 6-4, give a complete description of the part, its function, and its location.

Table 6-1. Reference Designators

A = assembly	E = miscellaneous
B = blower (fan)	electronic part
C = capacitor	F = fuse
CB = circuit breaker	J = jack, jumper
CR = diode	K = relay
DS = device, signaling (lamp)	L = inductor
	M = meter

Table 6-1. Reference Designators (Continued)

P = plug	V = vacuum tube,
Q = transistor	neon bulb,
R = resistor	photocell, etc.
S = switch	VR = zener diode
T = transformer	X = socket
TB = terminal block	Z = integrated cir-
TS = thermal switch	cuit or network

Table 6-2. Description Abbreviations

A = ampere	mod. = modular or
ac = alternating current	modified
assy. = assembly	mtg = mounting
bd = board	n = nano = $10^{-9}$
bkt = bracket	NC = normally closed
$^{\circ}\text{C}$ = degree Centigrade	NO = normally open
cd = card	NP = nickel-plated
coef = coefficient	$\Omega$ = ohm
comp = composition	obd = order by
CRT = cathode-ray tube	description
CT = center-tapped	OD = outside diameter
dc = direct current	p = pico = $10^{-12}$
DPDT = double pole,	P.C. = printed circuit
double throw	pot. = potentiometer
DPST = double pole,	p-p = peak-to-peak
single throw	ppm = parts per million
elect = electrolytic	pvr = peak reverse
encap = encapsulated	voltage
F = farad	rect = rectifier
$^{\circ}\text{F}$ = degree Fahrenheit	rms = root mean square
fxd = fixed	Si = silicon
Ge = germanium	SPDT = single pole,
H = Henry	double throw
Hz = Hertz	SPST = single pole,
IC = integrated circuit	single throw
ID = inside diameter	SS = small signal
incnd = incandescent	T = slow-blow
k = kilo = $10^3$	tan. = tantalum
m = milli = $10^{-3}$	Ti = titanium
M = mega = $10^6$	V = volt
$\mu$ = micro = $10^{-6}$	var = variable
met. = metal	ww = wirewound
mfr = manufacturer	W = Watt

Table 6-3. Code List of Manufacturers

CODE	MANUFACTURER	ADDRESS	CODE	MANUFACTURER	ADDRESS
00629	EBY Sales Co., Inc.	Jamaica, N.Y.	07137	Transistor Electronics Corp.	Minneapolis, Minn.
00656	Aerovox Corp.	New Bedford, Mass.	07138	Westinghouse Electric Corp.	Elmira, N.Y.
00853	Sangamo Electric Co.	S. Carolina Div. Pickens, S.C.	07263	Fairchild Camera and Instrument	Mountain View, Calif.
01121	Allen Bradley Co.	Milwaukee, Wis.	07387	Birtcher Corp., The	Los Angeles, Calif.
01255	Litton Ind.	Beverly Hills, Calif.	07397	Sylvania Electric Prod. Inc.	Mountainview, Calif.
01281	TRW Semiconductors, Inc.	Lawndale, Calif.	07716	IRC Div. of TRW Inc.	Burlington, Iowa
01295	Texas Instruments, Inc.	Dallas, Texas	07910	Continental Device Corp.	Hawthorne, Calif.
01686	RCL Electronics, Inc.	Manchester, N.H.	07933	Raytheon Co. Components Div.	Mountain View, Calif.
01930	Amerock Corp.	Rockford, Ill.	08484	Breeze Corporations, Inc.	Union, N.J.
02107	Sparta Mfg. Co.	Dover, Ohio	08530	Reliance Mica Corp.	Brooklyn, N.Y.
02114	Ferrocube Corp.	Saugerties, N.Y.	08717	Sloan Company, The	Sun Valley, Calif.
02606	Fenwal Laboratories	Morton Grove, Ill.	08730	Vemaline Products Co. Inc.	Wyckoff, N.J.
02660	Amphenol Corp.	Broadview, Ill.	08806	General Elect. Co. Miniature	Lamp Dept. Cleveland, Ohio
02735	Radio Corp. of America, Solid State and Receiving Tube Div.	Somerville, N.J.	08863	Nylomatic Corp.	Norrisville, Pa.
03508	G.E. Semiconductor Products Dept.	Syracuse, N.Y.	08919	RCH Supply Co.	Vernon, Calif.
03797	Eldema Corp.	Compton, Calif.	09021	Airco Speer Electronic Components	Bradford, Pa.
03877	Transitron Electronic Corp.	Wakefield, Mass.	09182	*Hewlett-Packard Co. New Jersey Div.	Rockaway, N.J.
03888	Pyrofilm Resistor Co., Inc.	Cedar Knolls, N.J.	09213	General Elect. Co. Semiconductor	Prod. Dept. Buffalo, N.Y.
04009	Arrow, Hart and Hegeman Electric Co.	Hartford, Conn.	09214	General Elect. Co. Semiconductor	Prod. Dept. Auburn, N.Y.
04072	ADC Electronics, Inc.	Harbor City, Calif.	09353	C & K Components Inc.	Newton, Mass.
04213	Caddell & Burns Mfg. Co. Inc.	Mineola, N.Y.	09922	Burndy Corp.	Norwalk, Conn.
04404	*Hewlett-Packard Co. Palo Alto Div.	Palo Alto, Calif.	11115	Wagner Electric Corp.	Tung-Sol Div. Bloomfield, N.J.
04713	Motorola Semiconductor Prod. Inc.	Phoenix, Arizona	11236	CTS of Berne, Inc.	Berne, Ind.
05277	Westinghouse Electric Corp.	Semiconductor Dept. Youngwood, Pa.	11237	Chicago Telephone of Cal. Inc.	So. Pasadena, Calif.
05347	Ultronix, Inc.	Grand Junction, Colo.	11502	IRC Div. of TRW Inc.	Boone, N.C.
05820	Wakefield Engr. Inc.	Wakefield, Mass.	11711	General Instrument Corp.	Newark, N.J.
06001	General Elect. Co. Electronic	Capacitor & Battery Dept. Irmo, S.C.	12136	Philadelphia Handle Co.	Camden, N.J.
06004	Bassik Div. Stewart-Warner Corp.	Bridgeport, Conn.	12615	U.S. Terminals, Inc.	Cincinnati, Ohio
06486	IRC Div. of TRW Inc.	Semiconductor Plant Lynn, Mass.	12617	Hamlin Inc.	Lake Mills, Wisconsin
06540	Amatom Electronic Hardware Co. Inc.	New Rochelle, N.Y.	12697	Clarostat Mfg. Co. Inc.	Dover, N.H.
06555	Beede Electrical Instrument Co.	Penacook, N.H.	13103	Thermalloy Co.	Dallas, Texas
06666	General Devices Co.	Indianapolis, Ind.	14493	*Hewlett-Packard Co.	Loveland, Colo.
06751	Semoor Div. Components, Inc.	Phoenix, Arizona	14655	Cornell-Dubilier Electronics Div.	Federal Pacific Electric Co.
06776	Robinson Nugent, Inc.	New Albany, N.Y.	14936	General Instrument Corp. Semicon-	ductor Prod. Group Hicksville, N.Y.
06812	Torrington Mfg. Co.	Van Nuys, Calif.	15801	Fenwal Elect.	Frammingham, Mass.
			16299	Corning Glass Works	Raleigh, N.C.

\* Use Code 28480 assigned to Hewlett-Packard Co., Palo Alto, California

Table 6-3. Code List of Manufacturers

CODE	MANUFACTURER	ADDRESS
16758	Delco Radio Div. of General Motors Corp.	Kokomo, Ind.
17545	Atlantic Semiconductors, Inc.	Asbury Park, N.J.
17803	Fairchild Camera and Instrument Corp.	Mountain View, Calif.
17870	Daven Div. Thomas A. Edison Industries McGraw-Edison Co.	Orange, N.J.
18324	Signetics Corp.	Sunnyvale, Calif.
19315	Bendix Corp. The Navigation and Control Div.	Teterboro, N.J.
19701	Electra/Midland Corp.	Mineral Wells, Texas
21520	Fansteel Metallurgical Corp.	No. Chicago, Ill.
22229	Union Carbide Corp. Electronics Div.	Mountain View, Calif.
22753	UID Electronics Corp.	Hollywood, Fla.
23936	Pamotor, Inc.	Pampa, Texas
24446	General Electric Co.	Schenectady, N.Y.
24455	General Electric Co.	Nela Park, Cleveland, Ohio
24655	General Radio Co.	West Concord, Mass.
24681	LTV Electrosystems Inc. Memcor/Components Operations	Huntington, Ind.
26982	Dynacool Mfg. Co. Inc.	Saugerties, N.Y.
27014	National Semiconductor Corp.	Santa Clara, Calif.
28480	Hewlett-Packard Co.	Palo Alto, Calif.
28520	Heyman Mfg. Co.	Kenilworth, N.J.
28875	IMC Magnetics Corp.	Rochester, N.H.
31514	SAE Advance Packaging, Inc.	Santa Ana, Calif.
31827	Budwig Mfg. Co.	Ramona, Calif.
33173	G.E. Co. Tube Dept.	Owensboro, Ky.
35434	Lectrohm, Inc.	Chicago, Ill.
37942	P.R. Mallory & Co.	Indianapolis, Ind.
42190	Muter Co.	Chicago, Ill.
43334	New Departure-Hyatt Bearings Div. General Motors Corp.	Sandusky, Ohio
44655	Ohmite Manufacturing Co.	Skokie, Ill.
46384	Penn Engr. and Mfg. Corp.	Doylestown, Pa.
47904	Polaroid Corp.	Cambridge, Mass.
49956	Raytheon Co.	Lexington, Mass.
55026	Simpson Electric Co. Div. of American Gage and Machine Co.	Chicago, Ill.
56289	Sprague Electric Co.	North Adams, Mass.
58474	Superior Electric Co.	Bristol, Conn.
58849	Syntron Div. of FMC Corp.	Homer City, Pa.

CODE	MANUFACTURER	ADDRESS
59730	Thomas and Betts Co.	Philadelphia, Pa.
61637	Union Carbide Corp.	New York, N.Y.
63743	Ward Leonard Electric Co.	Mt. Vernon, N.Y.
70563	Amperite Co. Inc.	Union City, N.J.
70901	Beemer Engrg Co.	Fort Washington, Pa.
70903	Belden Corp.	Chicago, Ill.
71218	Bud Radio, Inc.	Willoughby, Ohio
71279	Cambridge Thermionic Corp.	Cambridge, Mass.
71400	Bussmann Mfg. Div. of McGraw & Edison Co.	St. Louis, Mo.
71450	CTS Corp.	Ekhart, Ind.
71468	I.T.T. Cannon Electric Inc.	Los Angeles, Calif.
71590	Globe-Union Inc.	Milwaukee, Wis.
71700	General Cable Corp. Cornish Wire Co. Div.	Williamstown, Mass.
71707	Coto Coil Co. Inc.	Providence, R.I.
71744	Chicago Miniature Lamp Works	Chicago, Ill.
71785	Cinch Mfg. Co. and Howard B. Jones Div.	Chicago, Ill.
71984	Dow Corning Corp.	Midland, Mich.
72136	Electro Motive Mfg. Co. Inc.	Willimantic, Conn.
72619	Dialight Corp.	Brooklyn, N.Y.
72699	General Instrument Corp.	Newark, N.J.
72765	Drake Mfg. Co.	Harwood Heights, Ill.
72962	Elastic Stop Nut Div. of Amerace Esna Corp.	Union, N.J.
72982	Erie Technological Products	Erie, Pa.
73096	Hart Mfg. Co.	Hartford, Conn.
73138	Beckman Instruments	Fullerton, Calif.
73168	Fenwal, Inc.	Ashland, Mass.
73293	Hughes Aircraft Co. Electron Dynamics Div.	Torrance, Calif.
73445	Amperex Electronic	Hicksville, N.Y.
73506	Bradley Semiconductor Corp.	New Haven, Conn.
73559	Carling Electric, Inc.	Hartford, Conn.
73734	Federal Screw Products, Inc.	Chicago, Ill.
74193	Heinemann Electric Co.	Trenton, N.J.
74545	Hubbell Harvey Inc.	Bridgeport, Conn.
74868	Amphenol Corp. Amphenol RF Div.	Danbury, Conn.
74970	E. F. Johnson Co	Waseca, Minn.

Table 6-3. Code List of Manufacturers

CODE	MANUFACTURER	ADDRESS	CODE	MANUFACTURER	ADDRESS
75042	IRC Div. of TRW, Inc.	Philadelphia, Pa.	82866	Research Products Corp.	Madison, Wisc.
75183	*Howard B. Jones Div. of Cinch Mfg. Corp.	New York, N.Y.	82877	Rotron Inc.	Woodstock, N.Y.
75376	Kurz and Kasch, Inc.	Dayton, Ohio	82893	Vector Electronic Co.	Glendale, Calif.
75382	Kilka Electric Corp.	Mt. Vernon, N.Y.	83058	Carr Fastener Co.	Cambridge, Mass.
75915	Littlefuse, Inc.	Des Plaines, Ill.	83186	Victory Engineering	Springfield, N.J.
76381	Minnesota Mining and Mfg. Co.	St. Paul, Minn.	83298	Bendix Corp.	Eatontown, N.J.
76385	Minor Rubber Co. Inc.	Bloomfield, N.J.	83330	Herman H. Smith, Inc.	Brooklyn, N.Y.
76487	James Millen Mfg. Co. Inc.	Malden, Mass.	83385	Central Screw Co.	Chicago, Ill.
76493	J.W. Miller Co.	Compton, Calif.	83501	Gavitt Wire and Cable	Brookfield, Mass.
76530	Cinch	City of Industry, Calif.	83508	Grant Pulley and Hardware Co.	West Nyack, N.Y.
76854	Oak Mfg. Co. Div. of Oak Electro/ Netics Corp.	Crystal Lake, Ill.	83594	Burroughs Corp.	Plainfield, N.J.
77068	Bendix Corp., Electrodynamics Div.	No. Hollywood, Calif.	83835	U.S. Radium Corp.	Morristown, N.J.
77122	Palnut Co.	Mountainside, N.J.	83877	Yardeny Laboratories	New York, N.Y.
77147	Patton-MacGuyer Co.	Providence, R.I.	84171	Arco Electronics, Inc.	Great Neck, N.Y.
77221	Phostron Instrument and Electronic Co.	South Pasadena, Calif.	84411	TRW Capacitor Div.	Ogallala, Neb.
77252	Philadelphia Steel and Wire Corp.	Philadelphia, Pa.	86684	RCA Corp.	Harrison, N.J.
77342	American Machine and Foundry Co.	Princeton, Ind.	86838	Rummel Fibre Co.	Newark, N.J.
77630	TRW Electronic Components Div.	Camden, N.J.	87034	Marco & Oak Industries	Anaheim, Calif.
77764	Resistance Products Co.	Harrisburg, Pa.	87216	Philco Corp.	Lansdale, Pa.
78189	Illinois Tool Works Inc.	Elgin, Ill.	87585	Stockwell Rubber Co.	Philadelphia, Pa.
78452	Everlook Chicago, Inc.	Chicago, Ill.	87929	Tower-Olschan Corp.	Bridgeport, Conn.
78488	Stackpole Carbon Co.	St. Marys, Pa.	88140	Cutler-Hammer Inc.	Lincoln, Ill.
78526	Stanwyck Winding Div. San Fernando Electric Mfg. Co. Inc.	Newburgh, N.Y.	88245	Litton Precision Products Inc, USECO	Van Nuys, Calif.
78553	Tinnerman Products, Inc.	Cleveland, Ohio	90634	Gulton Industries Inc.	Metuchen, N.J.
78584	Stewart Stamping Corp.	Yonkers, N.Y.	90763	United-Car Inc.	Chicago, Ill.
79136	Waldes Kohinoor, Inc.	L.I.C., N.Y.	91345	Miller Dial and Nameplate Co.	El Monte, Calif.
79307	Whitehead Metals Inc.	New York, N.Y.	91418	Radio Materials Co.	Chicago, Ill.
79727	Continental-Wirt Electronics Corp.	Philadelphia, Pa.	91506	Augat, Inc.	Attleboro, Mass.
79963	Zierick Mfg. Co.	Mt. Kisco, N.Y.	91637	Dale Electronics, Inc.	Columbus, Neb.
80031	Mepco	Morristown, N.J.	91662	Elco Corp.	Willow Grove, Pa.
80294	Bourns, Inc.	Riverside, Calif.	91929	Honeywell Inc.	Freeport, Ill.
81042	Howard Industries	Racine, Wisc.	92825	Whitso, Inc.	Schiller Pk., Ill.
81073	Grayhill, Inc.	La Grange, Ill.	93332	Sylvania Electric Prod.	Woburn, Mass.
81483	International Rectifier	El Segundo, Calif.	93410	Essex Wire Corp.	Mansfield, Ohio
81751	Columbus Electronics	Yonkers, N.Y.	94144	Raytheon Co.	Quincy, Mass.
82099	Goodyear Sundries & Mechanical Co. Inc.	New York, N.Y.	94154	Wagner Electric Corp.	Livingston, N.J.
82142	Airco Speer Electronic Components	Du Bois, Pa.	94222	Southco Inc.	Lester, Pa.
82219	Sylvania Electric Products Inc.	Emporium, Pa.	95263	Leecraft Mfg. Co. Inc.	L.I.C., N.Y.
82389	Switchcraft, Inc.	Chicago, Ill.	95354	Methode Mfg. Co.	Rolling Meadows, Ill.
82647	Metals and Controls Inc.	Attleboro, Mass.	95712	Bendix Corp.	Franklin, Ind.
			95987	Weckesser Co. Inc.	Chicago, Ill.
			96791	Amphenol Corp.	Janesville, Wis.
			97464	Industrial Retaining Ring Co.	Irvington, N.J.
			97702	IMC Magnetics Corp.	Westbury, N.Y.
			98291	Seaelectro Corp.	Mamaroneck, N.Y.
			98410	ETC Inc.	Cleveland, Ohio
			98978	International Electronic Research Corp.	Burbank, Calif.
			99934	Renbrandt, Inc.	Boston, Mass.

\*Use Code 71785 assigned to Cinch Mfg. Co., Chicago, Ill.



Table 6-4. Replaceable Parts

REF. DESIG.	DESCRIPTION	TQ	MFR. PART NO.	MFR. CODE	HP PART NO.	RS
	<b>A1 Control Board (See Note 1)</b>					
C1	fxd, polyester .015 $\mu$ F 200V	1	AE14C153KT	06001	0160-0194	1
C2	fxd, polyester .22 $\mu$ F 80V	1	192P2249R8	56289	0160-2453	1
C3	fxd, polyester 6800pF 200V	1	AE13C682KT	06001	0160-0159	1
C4	fxd, polyester .022 $\mu$ F 200V	1	192P22392	56289	0160-0162	1
C5, 6	fxd, tant 22 $\mu$ F 15V	2	150D226X9015B-DS2	56289	0180-0228	1
C7	fxd, polyester 2200pF 200V	1	292P22292	56289	0160-0154	1
C8	Not Used					
C9	fxd, cer. .01 $\mu$ F 1000V	1		28480	0150-0012	1
C10, 11	Not Used					
C12	fxd, tant 180 $\mu$ F 6V	3	150D187X0006R2-DYS	56289	0180-1702	1
C13	fxd, tant 100 $\mu$ F 10V	1	150D107X0010R2-DYS	56289	0180-0137	1
C14	fxd, tant 180 $\mu$ F 6V	1	150D187X0006R2-DYS	56289	0180-1702	1
C15	fxd, mica 560pF 300V	1	obd	72136	0140-0178	1
C16	Not Used					
C17	fxd, tant 180 $\mu$ F 6V		150D187X0006R2-DYS	56289	0180-1702	
C18-22	Not Used					
C23	fxd, mica 220pF 300V	1	obd	09023	0160-0134	1
C24	fxd, tant 1 $\mu$ F 50V	1	150D105X0050A2-DYS	56289	0180-0230	1
C25	fxd, cer. 0.47 $\mu$ F 25V	1	5C11B7-CML	56289	0160-0174	1
C26	fxd, mica 100pF 500V	2	obd	72136	0160-2006	1
C27, 28	fxd, alum. 2000 $\mu$ F 28V	2	D44591-DFP	56289	0180-1916	1
C29, 30	Not Used					
C31	fxd, mica 100pF 500V		obd	72136	0160-2006	
C32	fxd, tant 2.2 $\mu$ F 20V	1	150D225X0020A2-DYS	56289	0180-0155	1
C33	fxd, tant 6.8 $\mu$ F 35V	1	150D685X9035B2	56289	0180-0116	1
CR1	diode, switching 80V 200mA	8	1N4148	07263	1901-0050	6
CR2, 3	diode, Si. 200ma 180V	6	1N485		1901-0033	6
CR4	diode, switching 80V 200mA		1N4148	07263	1901-0050	
CR5-8	diode, Si. 200mA 180V		1N485		1901-0033	
CR9	diode, switching 80V 200mA		1N4148	07263	1901-0050	
CR10	diode, Schottky barrier	1		28480	1901-0518	1
CR11	diode, switching 80V 200mA		1N4148	07263	1901-0050	
CR12	diode, rectifier 200V 1A	1	1N5059	03508	1901-0327	1
CR13	diode, stabistor 15V 150mA	1	STB-523	03508	1901-0460	1
CR14, 15	Not Used					
CR16, 17	diode, switching 80V 200mA		1N4148	07263	1901-0050	
CR18-20	Not Used					
CR21, 22	diode, switching 80V 200mA		1N4148	07263	1901-0050	
J7	Connector 21 pin	1	87236-4	Amp Inc.	1251-4658	1
J8	Connector 5 pin	1	2-87236-0	Amp Inc.	1251-4657	1
P6	Connector PC edge 36 pin	1	252-18-30-340	71785	1251-2134	1
Q1, 2	SS NPN Si	5	2N3391		1854-0071	5
Q3	SS NPN Si	1	2N2222A		1854-0477	1
Q4	SS PNP Si	1	TZ173	56289	1853-0099	1
Q5	SS PNP Si	1	2N2907A		1853-0281	1
Q6, 7	SS PNP Si	2	2N3906		1853-0036	

Note 1: This assembly is designed for component level repair. Replacement assemblies cannot be supplied.

Table 6-4. Replaceable Parts

REF. DESIG.	DESCRIPTION	TQ	MFR. PART NO.	MFR. CODE	HP PART NO.	RS
Q8	SS NPN Si	1		28480	1854-0448	1
Q9	SS NPN Si	1	MJE-182	04713	1854-0585	1
Q10-12	SS NPN Si		2N3391		1854-0071	
R1	var. ww 5k 5%	1	CT-106-4	84048	2100-1760	1
R2	fxd, ww 10k 5% 3W	1	RS-2B	91637	0811-1816	1
R3	fxd, ww 15 5% 3W	1	RS-2B	91637	0811-1557	1
R4	fxd, comp. 8.2k 5% 1/2W	2	EB-8225	01121	0686-8225	1
R5	fxd, film 34.8k 1% 1/8W	1	CEA T-O	07716	0757-0123	1
R6	var. ww 100 5%	1	CT-106-4	84048	2100-1755	1
R7, 8	fxd, film 2.49k 1% 1/8W	4	CEA T-O	07716	0698-4435	1
R9, 10	Not Used					
R11	fxd, comp 240 5% 1/2W	2	EB-2415	01121	0686-2415	1
R12, 13	fxd, ww 2.6k 5% 3W	2	RS-2B	91637	0811-1808	1
R14	fxd, ww 4.3k 5% 3W	1	RS-2B	91637	0811-1811	1
R15	var. ww 2k 5%	1	CT-106-4	84048	2100-1523	1
R16, 17	Not Used					
R18	fxd, film 1k 1% 1/8W	2	CEA T-O	07716	0757-0280	1
R19	fxd, ww 1k 5% 3W	1	RS-2B	91637	0813-0001	1
R20	Not Used					
R21	fxd, film 3.01k 1% 1/8W	2	CEA T-O	07716	0757-0273	1
R22	fxd, comp 8.2k 5% 1/2W		EB-8225	01121	0686-8225	
R23	fxd, comp 240 5% 1/2W		EB-2415	01121	0686-2415	
R24	fxd, comp 360 5% 1/2W	2	EB-3615	01121	0686-3615	1
R25	fxd, comp 820 5% 1W	1	GB-8215	01121	0689-8215	1
R26	fxd, comp 560 5% 1/2W	1	EB-5615	01121	0686-5615	1
R27	fxd, film 15k 1% 1/8W	1	CEA T-O	07716	0757-0446	1
R28	fxd, comp 1.2k 5% 1/2W	1	EB-1225	01121	0686-1225	1
R29	fxd, film 100 5% 1/4W	1	CB-1015	01121	0683-1015	1
R30	fxd, comp 15 5% 1/2W	1	EB-1505	01121	0686-1505	1
R31	fxd, comp 2k 5% 1/2W	1	EB-2025	01121	0686-2025	1
R32	fxd, comp 22 5% 1/2W	1	EB-2205	01121	0686-2205	1
R33	fxd, ww 500 5% 5W	1	RS-5	91637	0811-1858	1
R34, 35	Not Used					
R36	fxd, film 100k 0.1% 1/8W	1	CEA-993	07716	0698-4158	1
R37	fxd, film 9k 0.1% 1/8W	2	CEA-993	07716	0698-5454	1
R38, 39	fxd, film 50k 0.1% 1/8W	2	CEA-993	07716	0698-5450	1
R40	fxd, film 2.37k 1% 1/8W	1	CEA T-O	07716	0698-3150	1
R41	fxd, film 10k 0.1% 1/8W	1	CEA-993	07716	0698-4157	1
R42	fxd, film 9k 0.1% 1/8W		CEA-993	07716	0698-5454	
R43	Not Used					
R44	fxd, film 21.5k 1% 1/8W	2	CEA T-O	07716	0757-0199	1
R45	fxd, film 1.5M 5% 1/4W	1	CB-1555	07716	0683-1555	1
R46	fxd, film 6.19k 1% 1/8W	3	CEA T-O	07716	0757-0290	1
R47	fxd, film 100k 1% 1/8W	3	CEA T-O	07716	0757-0465	1
R48	fxd, film 2.49k 1% 1/8W		CEA T-O	07716	0698-4435	
R49	fxd, film 6.19k 1% 1/8W		CEA T-O	07716	0757-0290	
R50	fxd, film 11.3k 1% 1/8W	2	CEA T-O	07716	0698-4121	1
R51	fxd, film 909 1% 1/8W	1	CEA T-O	07716	0757-0422	1
R52	fxd, film 1.1k 1% 1/8W	3	CEA T-O	07716	0757-0424	1
R53	var. ww 250 20%	5	TYPE 110	11236	2100-0439	1

Table 6-4. Replaceable Parts

REF. DESIG.	DESCRIPTION	TQ	MFR. PART NO.	MFR. CODE	HP PART NO	RS
R54	fxd, film 11.3k 1% 1/8W		CEA T-O	07716	0698-4121	
R55	fxd, film 340k 1% 1/8W	2	CEA T-O	07716	0698-4536	1
R56	fxd, film 1.1k 1% 1/8W		CEA T-O	07716	0757-0424	1
R57	fxd, film 1.5k 1% 1/8W	1	CEA T-O	07716	0757-0427	1
R58	var. ww 250 20%		TYPE 110	11236	2100-0439	
R59	fxd, film 200k 1% 1/8W	2	CEA T-O	07716	0757-0472	1
R60	fxd, film 8.66k 1% 1/8W	1	CEA T-O	07716	0698-3498	1
R61	fxd, film 42.2k 1% 1/8W	2	CEA T-O	07716	0698-3450	1
R62	fxd, film 1M 5% 1/4W	2	CB-1055	01121	0683-1055	1
R63	fxd, film 68.1k 1% 1/8W	1	CEA T-O	07716	0757-0461	1
R64-66	fxd, comp. 10k 5% 1/4W	7	CB-1035	01121	0683-1035	2
R67	fxd, film 200k 1% 1/8W		CEA T-O	07716	0757-0472	
R68	fxd, film 392 1% 1/8W	1	CEA T-O	07716	0757-0413	1
R69	Not Used					
R70	fxd, film 1M 5% 1/4W		CB-1055	01121	0683-1055	
R71	var. ww 250 20%		TYPE 110	11236	2100-0439	
R72	fxd, film 1.1k 1% 1/8W		CEA T-O	07716	0757-0424	
R73	fxd, comp 10k 5% 1/4W		CB-1035	01121	0683-1035	
R74	fxd, film 13.3k 1% 1/8W	2	CEA T-O	07716	0757-0289	1
R75	fxd, film 100k 1% 1/8W		CEA T-O	07716	0757-0465	
R76-78	Not Used					
R79	fxd, comp. 1k 5% 1/4W	1	CB-1025	01121	0683-1025	1
R80	fxd, film 42.2k 1% 1/8W		CEA T-O	07716	0698-3450	
R81	fxd, film 13.3k 1% 1/8W		CEA T-O	07716	0757-0465	
R82	fxd, film 21.5k 1% 1/8W		CEA T-O	07716	0757-0199	
R83-85	Not Used					
R86	fxd, film 348 1% 1/4W	1	CEB T-O	07716	0698-3445	
R87	fxd, film 3.01k 1% 1/8W		CEA T-O	07716	0757-0273	
R88	fxd, film 6.19k 1% 1/8W		CEA T-O	07716	0757-0290	
R89	fxd, comp 1k 5% 1/2W	2	EB-1025	01121	0686-1025	
R90	fxd, comp. 10k 5% 1/4W		CB-1035	01121	0683-1035	
R91	fxd, comp. 10 5% 1/2W	1	EB-1005	01121	0686-1005	
R92	Not Used					
R93	fxd, film 2.49k 1% 1/8W		CEA T-O	07716	0698-4435	
R94	fxd, film 1.21k 1% 1/8W	1	CEA T-O	07716	0757-0274	1
R95	fxd, film 332 1% 1/8W	2	CEA T-O	07716	0757-0411	1
R96	fxd, comp. 1.3k 5% 1/2W	1	EB-1325	01121	0686-1325	1
R97	fxd, comp 1k 5% 1W	2	GB-1025	01121	0689-1025	1
R98	fxd, comp. 1k 5% 1/2W		CB-1035	01121	0686-1025	
R99, 100	fxd, comp. 10k 5% 1/4W		CB-1035	01121	0683-1035	
R101	fxd, film 31.6k 1% 1/8W	1	CEA T-O	07716	0698-3160	
R102	fxd, film 340k 1% 1/8W		CEA T-O	07716	0698-4536	
R103	fxd, film 1k 1% 1/8W		CEA T-O	07716	0757-0280	
R104	fxd, film 100k 1% 1/8W		CEA T-O	07716	0757-0465	
R105	fxd, ww 510 5% 2W	1	TYPE BWH	75042	0811-1766	1
R106	fxd, comp. 510 5% 1W	1	GB-5115	01121	0689-5115	1
R107	fxd, comp 6.8 5% 1/2W	1	EB-68G5	01121	0698-5525	1
R108	fxd, comp. 1k 5% 1W		GB-1025	01121	0689-1025	
R109	fxd, comp. 3.3 5% 1/2W	1	EB-0335	01121	0686-0335	1
R110	fxd, comp. 360 5% 1/2W		EB-3615	01121	0686-3615	

Table 6-4. Replaceable Parts

REF. DESIG.	DESCRIPTION	TO	MFR. PART NO.	MFR. CODE	HP PART NO.	RS
R111	var. ww 250 20%		TYPE 110	11236	2100-0439	
R112	fxd, film 432 0.5% 1/8W	1	CEA-993	07716	0698-4186	1
R113	fxd, met. oxide 23k 2% 2W	1	RG42	11502	0763-0004	1
R114	fxd, film 576 1% 1/8W	1	CEA T-O	07716	0698-4457	1
R115	fxd, film 332 1% 1/8W		CEA T-O	07716	0757-0411	
R116	var. ww 250 20%		TYPE 110	11236	2100-0439	
T1	pulse transformer	1		28480	5080-1863	1
U1, 2	Dual linear op ampl. IC	2	MC1458	02735	1826-0143	2
U3	Quad linear op ampl. IC	1	SL24958	27014	1826-0138	1
U4	Quad 2-input NAND IC	1	CD4093BY	02735	1820-1577	1
U5	Quad D Latch IC	1	CD4042AY	02735	1820-1540	1
U6	Linear voltage regulator IC	1	SL22310	07263	1826-0049	1
U7	Not Used					
U8-10	Linear op ampl. IC	3	SL8641	27014	1820-0223	3
VR1	diode, zener 2.37V	2	SZ10939-2	04713	1902-3002	2
VR2	diode, zener 6.19V	1	SZ10939-122	04713	1902-0049	1
VR3	diode, zener 2.37V		SZ10939-2	04713	1902-3002	
VR4	Not Used					
VR5, 6	diode, zener 6.2V	2	1N825		1902-1221	2
VR7	diode, zener 11.8V	1	CD35728	15818	1902-3180	1
VR8	diode, zener 7.5V	1	SZ10939-146	04713	1902-0064	1
<b>A2 Interconnect Board (See Note 1)</b>						
C1	fxd, elect. 1600 $\mu$ F 85V	1	32D5279-DQB	56289	0180-1986	1
C2	fxd, elect. 22 $\mu$ F 35V	1	150D226X0035R2	56289	0180-0160	1
C3	fxd, cer. .05 $\mu$ F 400V	1	33C17A3-CDH	56289	0150-0052	1
C4	fxd, tant 33 $\mu$ F 75V	1	109D336X0075F2-DYP	56289	0180-0234	1
CR1, 2	diode si. 200V 1A	8	1N5059		1901-0327	6
CR3	diode, si. 200V 1.5A	2	1N4999		1901-0416	2
CR4-7	diode, si. 200V 1A		1N5059		1901-0327	
CR8	diode, si. 200V 1.5A		1N4999		1901-0416	
CR9, 10	diode, si. 200V 1A		1N5059		1901-0327	
CR11	voltage doubler	1	R712E	83003	1906-0088	1
CR12	Not Used					
CR13	Thyristor-SCR	1	38639	02735	1884-0058	1
J1, J2	connector - pins only	2		28480	1251-0646	
J3	connector 10 pin	1	1-380991-0	Amp Inc.	1251-4271	1
J4, 5	connector pc edge 12 pin	2	252-06-30-340	71785	1251-0478	1
Q1	power NPN Si.	1	2N3715		1854-0264	1
Q2	SS PNP Si.	1	SS1147	04713	1854-0448	1
R1	fxd, ww 50 5% 5W	1	RS-5	91637	0811-1854	1
R2	fxd, ww 5 5% 3W	1	RS-2B	91637	0812-0086	1
R3, 4	fxd, ww 0.4 5% 40W	2	BW20	24681	0811-1817	1
R5-10	fxd, ww 0.33 5% 3W	6	RS-2B	91637	0812-0019	2
R11	fxd, ww 10 5% 10W	1	RS-10	91637	0811-1895	1
R12, 13	fxd, ww 100 3% 5W	2	RS-5	91637	0812-0018	1
R14	fxd, comp. 68 5% 1/4W	1	CB-6805	01121	0683-6805	1
R15	fxd, ww 2 10% 5W	1	RS-5	91637	0811-1850	1
R16	fxd, ww 250 5% 5W	1	RS-5	91637	0811-1856	1

Table 6-4. Replaceable Parts

REF. DESIG.	DESCRIPTION	TQ	MFR. PART NO.	MFR. CODE	HP PART NO.	RS
R17	fxd, comp. 15 5% 1/2W	1	EB-1505	01121	0686-1505	1
R18	Not Used					
R19	fxd, comp. 33k 5% 1/2W	1	EB-3335	01121	0686-3335	
R20	fxd, comp. 4.7k 5% 1/2W	1	EB-4725	01121	0686-4725	1
TB1	Terminal Block 14 Term	1		28480	0360-1820	1
<b>A3 Input Board (See Note 1)</b>						
C1-3	fxd, cer. .05 $\mu$ F 400V	3	33C17A3-CDH	56289	0150-0052	1
C4, 5	fxd, alum. 7800 $\mu$ F 100V	2	36D4808	56289	0180-2389	1
C6	fxd, tant 6.8 $\mu$ F 35V	2	150D685X903582	56289	0180-0116	1
C7	fxd, polyester .022 $\mu$ F 200V	2	192P22392	56289	0160-0162	1
C8	fxd, tant 6.8 $\mu$ F 35V		150D685X903582	56289	0180-0116	
C9	fxd, polyester .022 $\mu$ F 200V		192P22392	56289	0160-0162	
CR1, 2	Not Used					
CR3, 4	diode, switching 80V 200mA	2	1N4148	07263	1901-0050	2
F1, 2	Fuse 6A 250V	2	312006	75915	2110-0056	5
Q1, 2	SS NPN Si.	2	SJE972	04713	1854-0585	2
P8	Cable assembly	1		28480	5060-2709	
R1-3	fxd, comp. 22 5% 1/2W	3	EB-2205	01121	0686-2205	1
R4	fxd, ww 5k 5% 5W	1	RS-5	91637	0812-0060	1
R5	Not Used					
R6	fxd, met. oxide 27 $\Omega$ 5% 2W	2	RG42	11502	0698-3611	1
R7	fxd, met. oxide 43 5% 2W	2	RG42	11502	0698-3614	1
R8	fxd, comp. 150 5% 1/2W	2	EB-1515	01121	0686-1515	1
R9	fxd, comp. 1k 5% 1/4W	2	CB-1025	01121	0683-1025	1
R10	fxd, ww. 2.7 5% 2W	2	BWH	75042	0811-1671	1
R11	fxd, met. oxide 27 5% 2W		RG42	11502	0698-3611	
R12	fxd, met. oxide 43 5% 2W		RG42	11502	0698-3614	
R13	fxd, comp. 150 5% 1/2W		EB-1515	01121	0686-1515	
R14	fxd, comp. 1k 5% 1/4W		CB-1025	01121	0683-1025	
R15	fxd, ww 2.7 5% 2W		BWH	75042	0811-1671	
T1, 2	pulse transformer	2		28480	5080-1785	1
<b>A4 Heatsink Board Top (See Note 1)</b>						
Q1-3	power NPN Si.	3	60675	02735	1854-0755	3
Q4	power PNP Si.	1	2N5954		1853-0277	1
<b>A5 Heatsink Board Bottom (See Note 1)</b>						
Q1-3	power NPN Si.	3	60675	02735	1854-0755	3
TC1	Thermal Switch (opens 248 $^{\circ}$ F $\pm$ 6 $^{\circ}$ ; closes 188 $^{\circ}$ F $\pm$ 12 $^{\circ}$ F)	1	430-900	72983	3103-0019	1
<b>Front Panel Electrical</b>						
C1	fxd, tant 33 $\mu$ F 75V	1	109D336X0075F2-DYP	56289	0180-0234	
DS1	LINE indicator light	1		28480	1450-0566	1
DS2, 3	Led, VOLTAGE MODE, CURRENT MODE	2		28480	1990-0521	2

Table 6-4. Replaceable Parts

REF. DESIG.	DESCRIPTION	TQ	MFR. PART NO.	MFR. CODE	HP PART NO.	RS
DS4, 5	Led, OVERVOLTAGE, OVERRANGE	2		28480	2990-0325	2
M1	voltmeter	1		28480	1120-1387	
M2	ammeter	1		28480	1120-1388	
P2	front panel cable assembly	1		28480	5060-2708	
P3	front panel cable assembly	1		28480	5060-2707	
P7	front panel cable assembly	1		28480	5060-2706	
R1	var. ww 50k VOLTAGE	1	8400	84048	2100-1994	1
R2	var. ww 1k CURRENT	1	8400	84048	2100-1864	1
R3	var. ww 5k OVERVOLTAGE	1	TYPE J	01121	2100-0790	1
S1	switch DPST toggle LINE	1	8926K317	27191	3101-0946	1
<b>Chassis - Electrical</b>						
B1	fan cooling 115V 50/60Hz	1	WS2107FL-55	28875	3160-0056	1
C2	fxd, paper 0.1 $\mu$ F 250V	1		28480	0160-4065	1
CR1, 2	Triac 200V 40A	2	T6420B	02735	1884-0255	2
F1	LINE fuse 6A, 250V (100/120)	1	312006	75915	2110-0056	5
	LINE fuse 4A, 250V (220/240)	1	312004	75915	2110-0055	5
T1	power transformer	1		28480	06002-80091	
U1, 2	Rectifier diode, assembly	2	SDA 10254-3	04713	1906-0017	1
<b>A1 Control Board - Mechanical</b>						
	Bumper, insulating	2		28480	0380-0514	
	heat dissipator, TO-5 (Q8)	1		28480	1205-0033	
<b>A2 Interconnect Board - Mechanical</b>						
	ground bracket	1		28480	06002-00004	
	heatsink, SCR	1		28480	06002-00005	
	terminal block jumpers	6		28480	0360-0523	
	heat dissipator TO-3 (Q1, CR11)	2		28480	1205-0267	
<b>A4 Heatsink Board Top - Mechanical</b>						
	heatsink	1		28480	06002-20001	
	spacer - noryl	3		28480	0380-0686	
	flat metal spacing washers	8		28480	3050-0010	
	transistor insulator-plastic (Q1-Q3)	3		28480	0340-0795	
	transistor insulator-mica (Q4)	1		28480	0340-0180	
	transistor insulator-plastic (Q4)	1		28480	0340-0548	
<b>A5 Heatsink Board Bottom - Mechanical</b>						
	heatsink	1		28480	06002-20001	
	spacer - noryl	3		28480	0380-0686	
	flat metal spacing washers	6		28480	3050-0010	
	transistor insulator-plastic (Q1-Q3)	3		28480	0340-0795	
<b>Front Panel - Mechanical</b>						
	front panel	1		28480	06002-00002	
	front panel trim	1		28480	06002-00001	

Table 6-4. Replaceable Parts

REF. DESIG.	DESCRIPTION	TO	MFR. PART NO.	MFR. CODE	HP PART NO.	RS
	knob (R1, R2)	2		28480	0370-1091	
	retainer, push-on	1		28480	0510-1157	
	knurled nut (S1)	1		28480	0590-0012	
	spring, compression, meter mount	8		28480	1460-0256	
	meter bezel	2		28480	4040-0906	
	panel bushing (R3)	1		28480	1410-0052	
	binding post, OUTPUT	2		28480	1510-0091	
	binding post, GND	1		28480	1510-0107	
	retainer led (DS2-DS5)	4		28480	1400-0540	
	clip-led (DS2-DS5)	4		28480	1400-0547	
	<b>Chassis – Mechanical</b>					
	front frame, 1/2 module	1		28480	5020-8817	
	top trim, front frame	1		28480	5040-7203	
	side, trim, front frame	2		28480	5001-0440	
	rear frame, 1/2 module	1		28480	5020-8818	
	rear panel	1		28480	06002-00003	
	corner strut, 17"	4		28480	5020-8836	
	front chassis, upper	1		28480	06002-00006	
	front chassis, lower	1		28480	06002-00007	
	rear chassis	1		28480	06002-00008	
	baffle plate	1		28480	06002-00011	
	cover-perforated, top/side 1/2 module	1		28480	5001-0464	
	strap handle, 15"	1		28480	5060-9803	
	front cap, strap handle	1		28480	5040-7219	
	rear cap, strap handle	1		28480	5040-7220	
	cover-perforated, bottom 1/2 module	1		28480	5060-9973	
	foot, 1/2 module	4		28480	5040-7201	
	cover, rear terminal block	1		28480	06002-20002	
	capacitor clamp (A3C4, A3C5)	2		28480	0180-1970	
	PC board guide (A2 bd)	4		28480	0403-0164	
	line module	1		28480	0960-0444	
	identification label (Serial Tag–	1		28480	7120-1111	
	standoff, hex, .375 in.	3		28480	0380-0175	
	standoff, hex, 1.062 in.	5		28480		
	standoff, hex, 1.562 in.	4		28480		
	<b>Miscellaneous</b>					
	packing carton	1		28480	9211-0617	
	float pad, packing carton	2		28480	9220-1494	
	Line Cord – One supplied according to user's location, as follows:					
	U. S., Canada, Japan, Italy and Spain	1		28480	8120-0050	
	Great Britain, United Kingdom			28480	8120-1351	
	East/West Europe, U. A. R.			28480	8120-1689	
	Australia, New Zealand			28480	8120-1369	

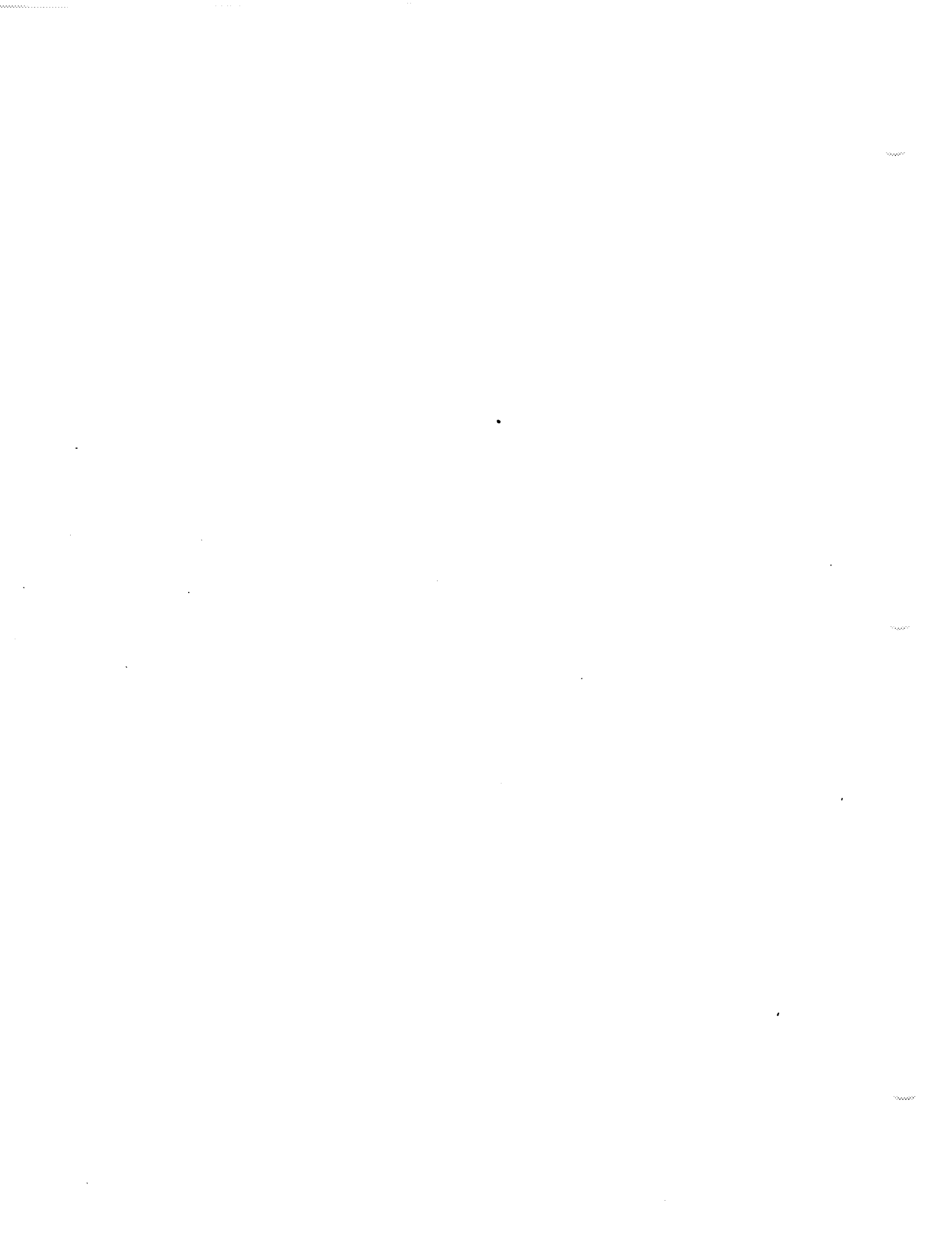



## SECTION VII CIRCUIT DIAGRAMS AND COMPONENT LOCATION DIAGRAMS

This section contains the circuit diagrams necessary for the operation and maintenance of the 6002A power supply. (Circuit diagrams for Option 001 are included in Appendix A.) Included in this section are:

a. Component location diagrams (Figures 7-1 through 7-7), showing the physical location and reference

designators of all power supply parts.

b. Logic circuit waveforms (Figure 7-8), showing waveforms which are used in conjunction with the troubleshooting procedures of Section V.

c. Schematic diagram (Figure 7-9), illustrating the circuitry for the entire power supply.

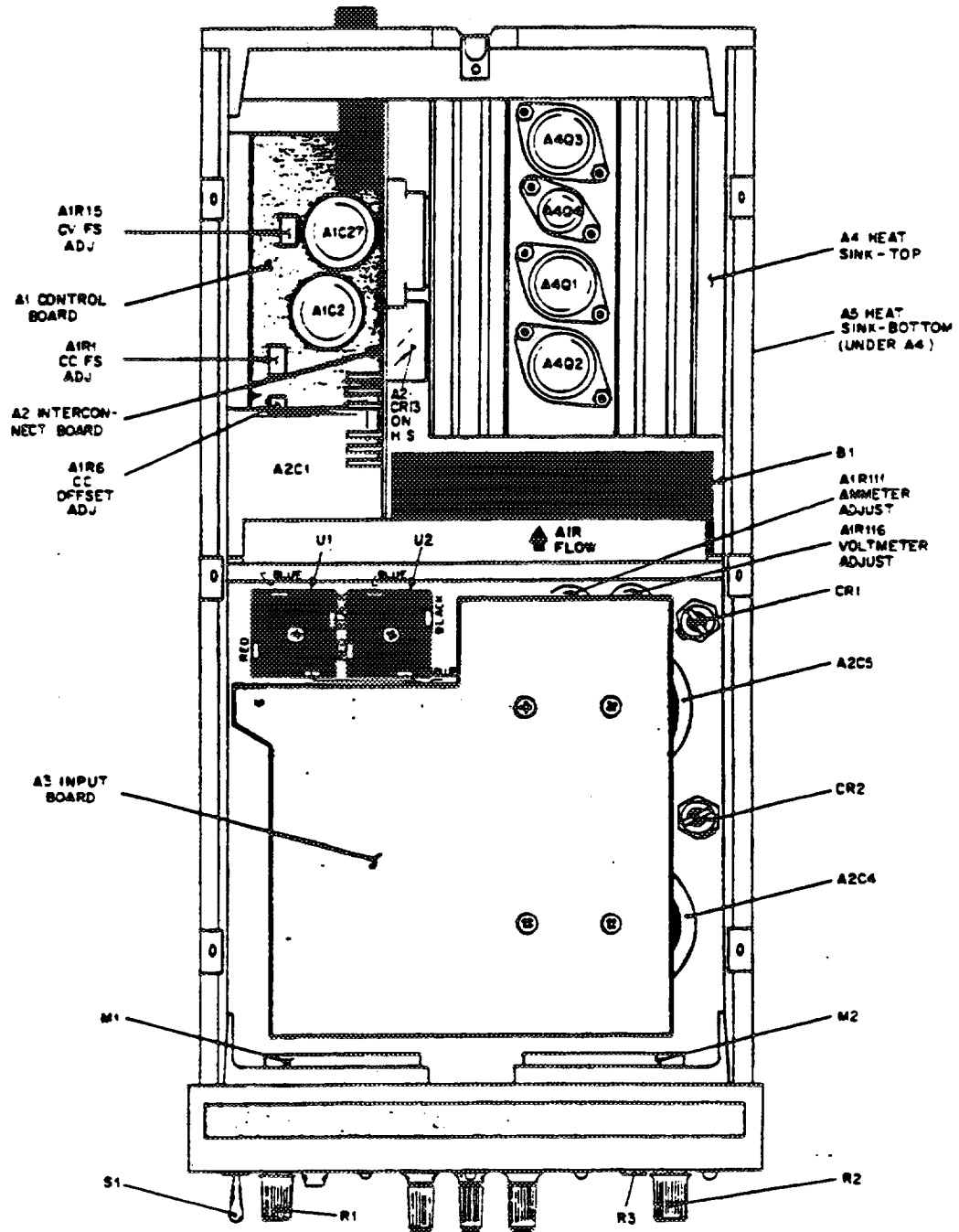

Figure 7-1. Overall View, Cover Removed

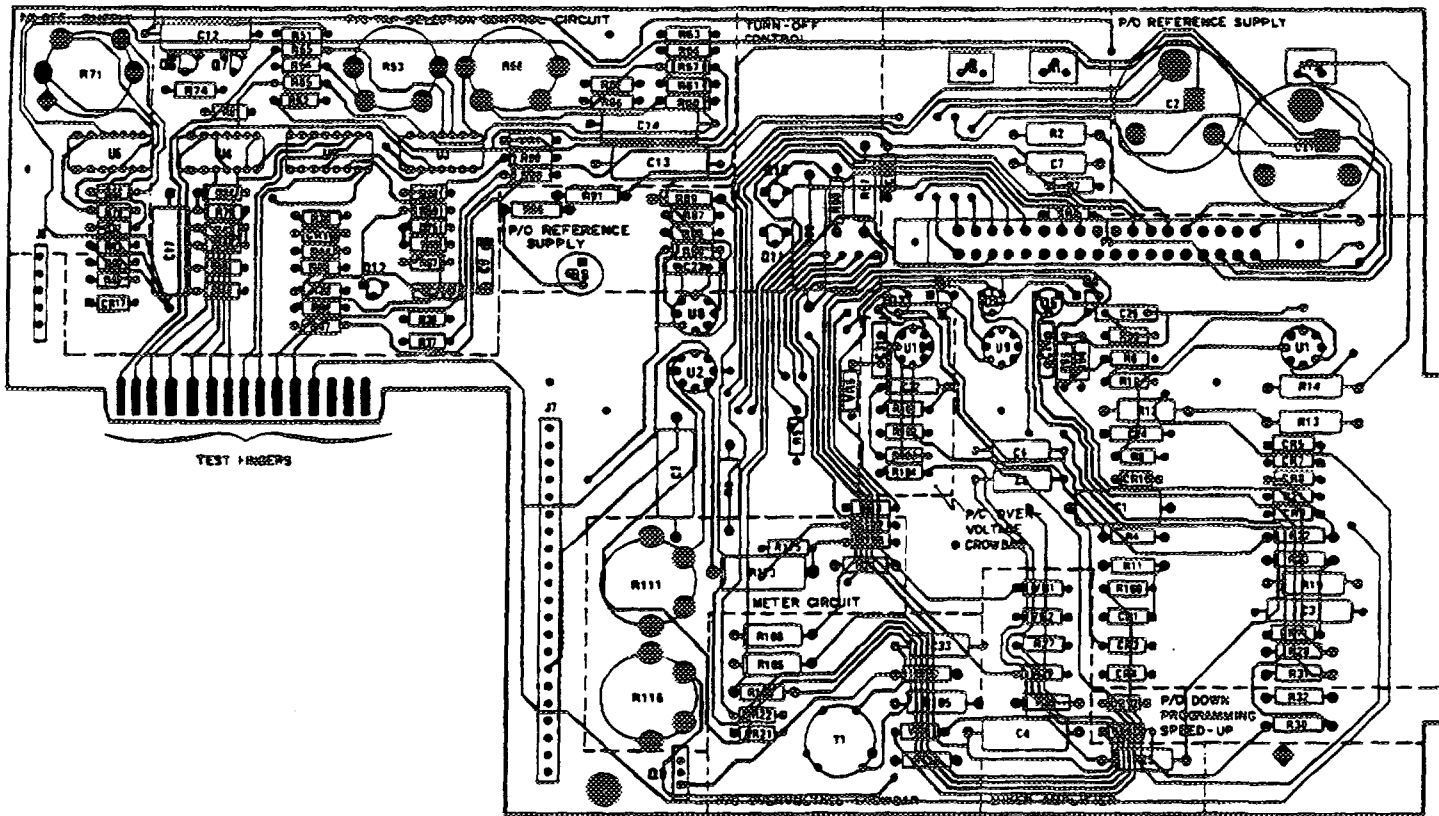

Figure 7-2. Control Board (A1), Component Side

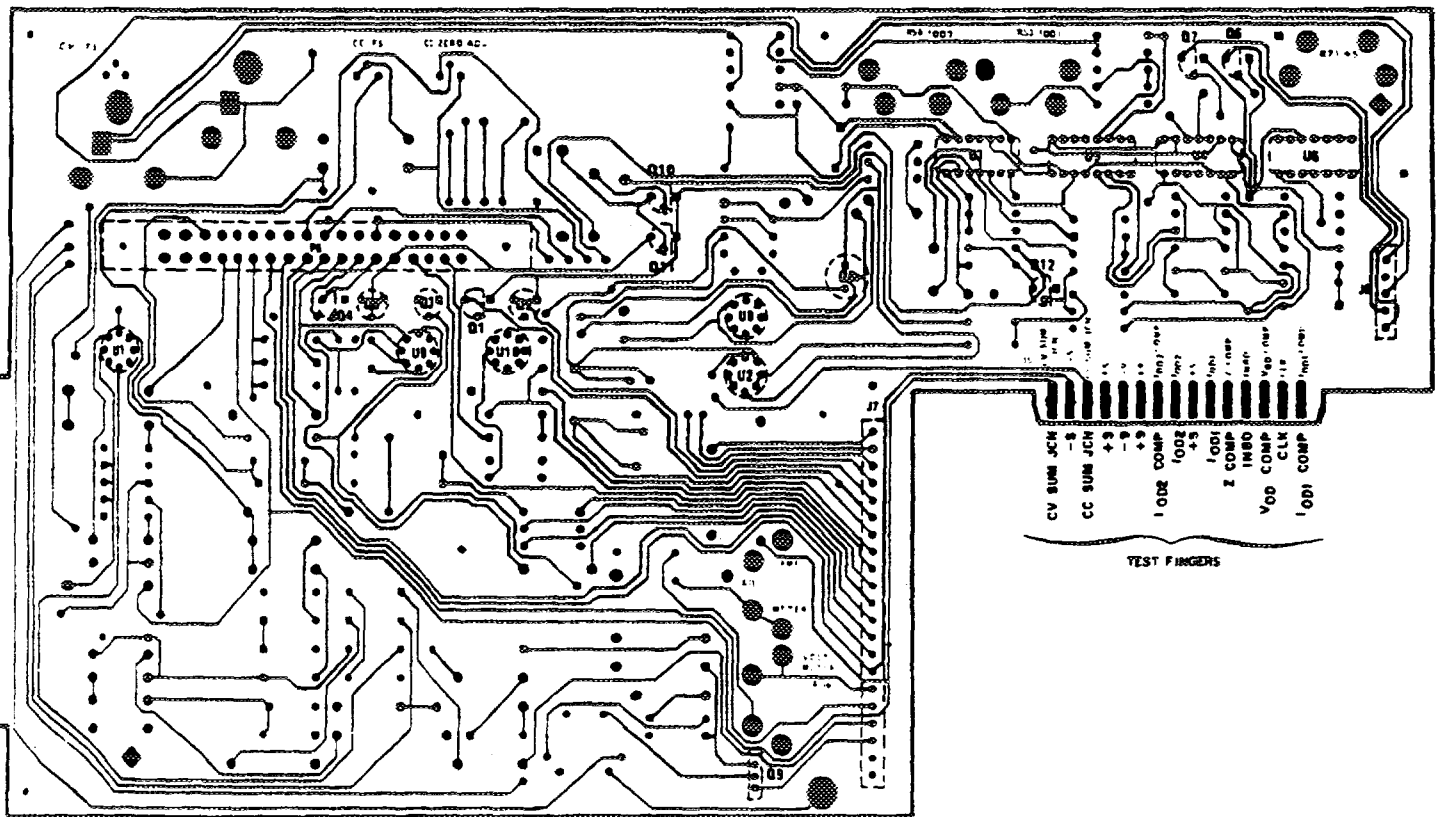

Figure 7-3. Control Board (A1), Circuit Side

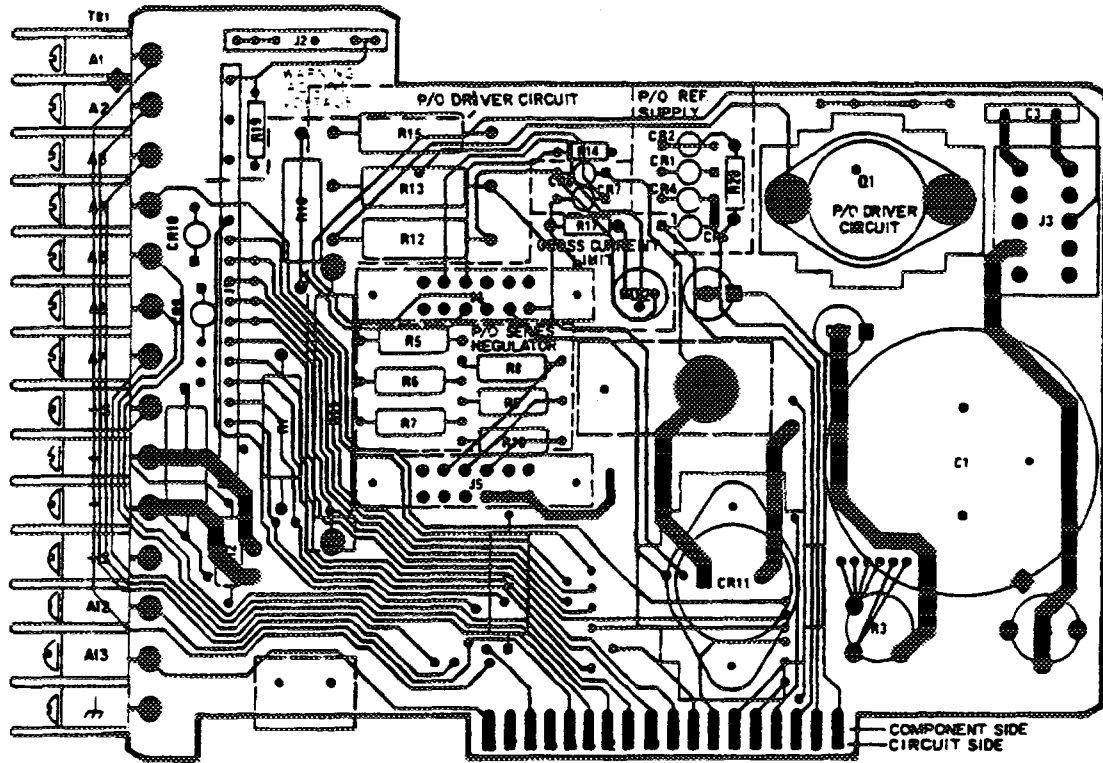

Figure 7-4. Interconnect Board (A2), Component Location

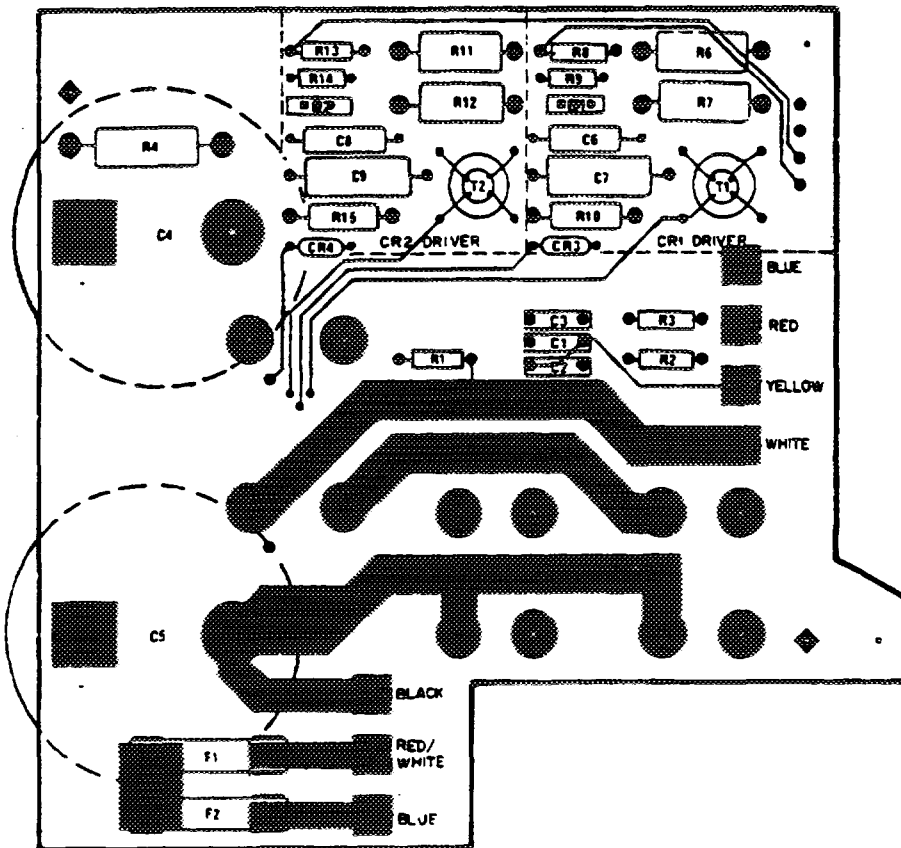

Figure 7-5. Input Board (A3), Component Location

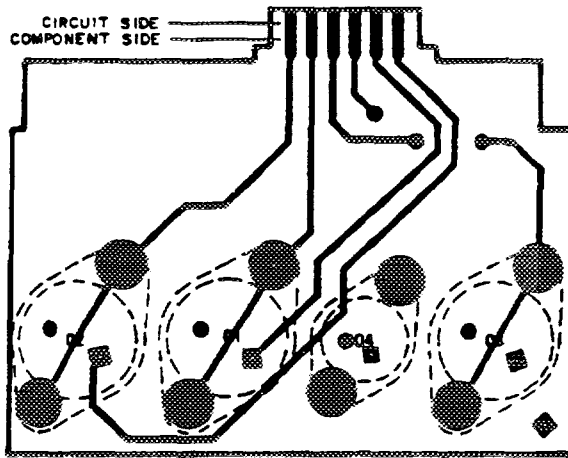

Figure 7-6. Top Heat Sink Board (A4), Component Location

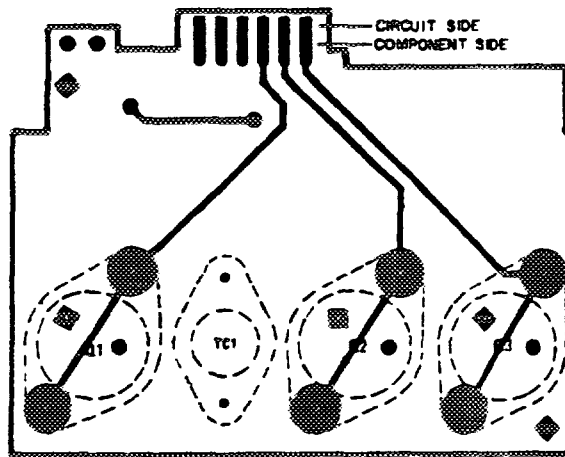

Figure 7-7. Bottom Heat Sink Board (A5), Component Location

**MEASUREMENT CONDITIONS**

1. ALL WAVEFORMS TAKEN WITH SUPPLY IN CONSTANT VOLTAGE MODE WITH A 40V, 4A OUTPUT (LOAD RESISTANCE OF ABOUT 10Ω). THIS ENSURES THAT BOTH TRIACS ARE RECEIVING FIRING PULSES.
2. OSCILLOSCOPE IS DC COUPLED. WAVEFORMS AT TP5 AND TP2 TAKEN AT A1 BOARD TEST FINGERS

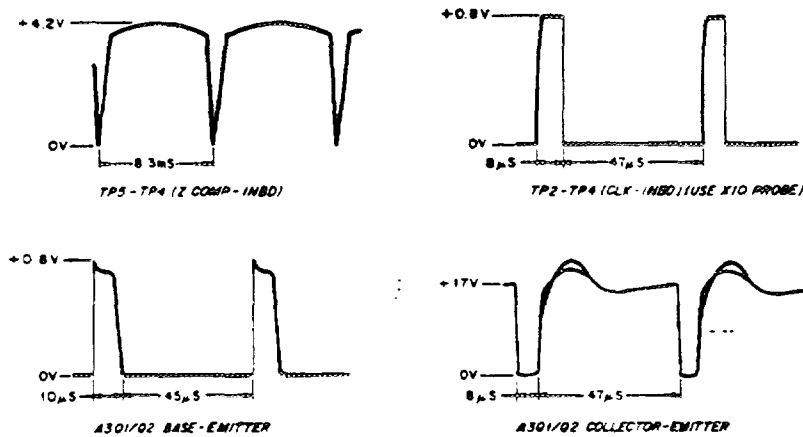

Figure 7-8. Control Logic Waveforms

## APPENDIX A HP-IB OPTION 001

### A-1 GENERAL INFORMATION

A-2 This option allows the 6002A power supply to be digitally controlled via the HP-IB from a calculator, computer, or other controller. The digital format is bit parallel, byte serial, ASCII coded format. With this option, an HP-IB controller can program the output voltage or current of the power supply. A pair of switches on the rear panel of the supply allows selecting any one of three modes of operation: Local, HP-IB constant voltage (CV), or HP-IB constant current (CC). There is no interaction with the HP-IB when in the local (front panel) mode.

### A-3 Option 001 Hardware

A-4 The Option 001 hardware consists of three printed circuit boards, the mode switches, address switches, and HP-IB connector. The three boards are installed in the rear (upper section) of the 6002A chassis (see Figure A-1). The switches and HP-IB connector are located on the rear of the supply.

A-5 The three boards are designated A100 Input Board, A200 Digital Board, and A300 Analog Board. The Option 001 circuits are interfaced with the 6002A power supply via a cable connected to the supply's A2 Interconnect Board. Connections between the Option 001 boards are hard wired. Operating voltages for the Option 001 circuitry are provided by dc power supplies on the A300 Analog Board.

### A-6 Operating on the HP-IB

A-7 The basic operation of the option enables the power supply to change its output in response to programmed data. The format of the programmed data word is a four-digit code (four ASCII characters). The first digit selects the output range while the remaining three digits determine the magnitude of the output voltage (or current if in the CC mode). The programmable range enables the user to obtain better resolution and accuracy when the power supply is operating below 10 volts (CV mode) or 2A (CC mode). No power supply control signals are returned to the controller. The following paragraphs provide a brief description of bus operations.

A-8 Figure A-1 illustrates the signal flow on the HP-IB between a controller (e. g. 9830A calculator) and the 6002A-001 power supply. Data is transferred over the bus on data

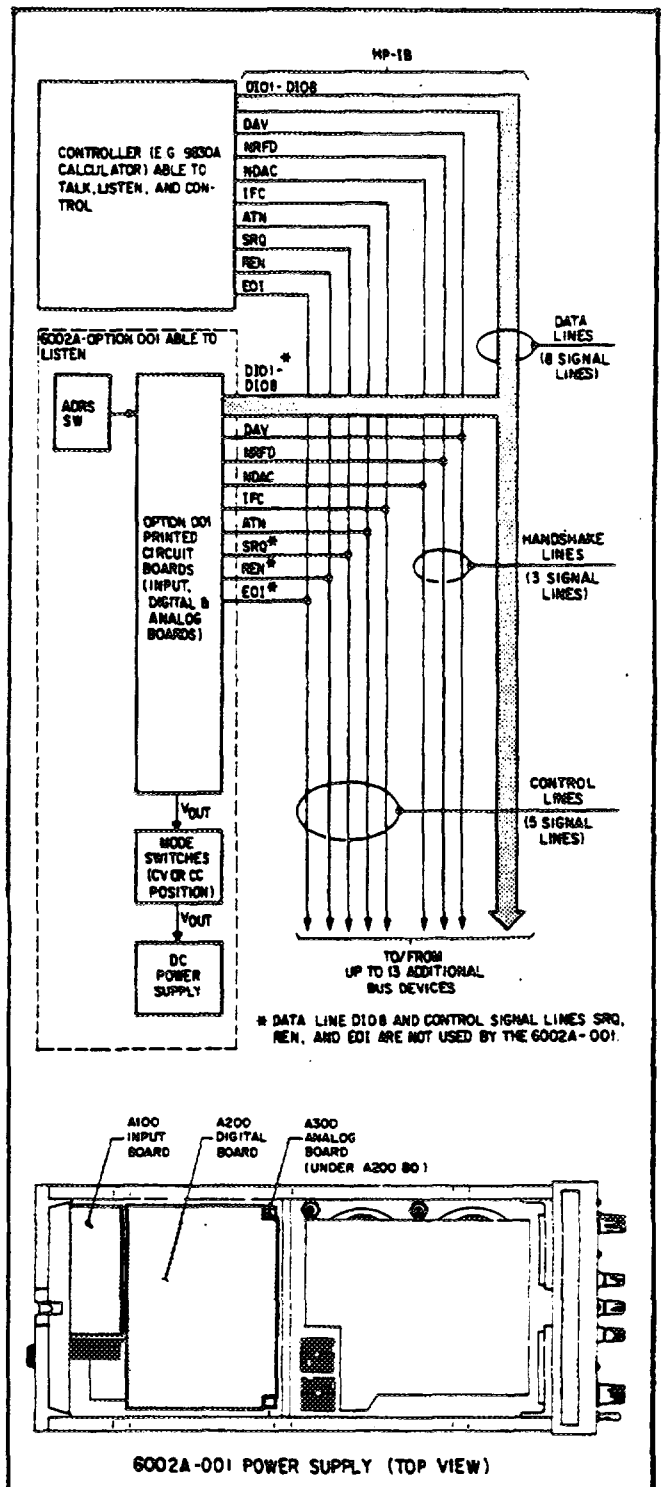

Figure A-1. Option 001 Circuits and Bus Connections

input/output lines D101-D108 utilizing the byte serial technique. Each byte (character) of information, 8-bits in parallel, is transferred onto the bus in serial fashion. Lines D101-D107 accommodate the 7-bits (1 character) of the ASCII code. Line D108 is not used by the 6002A but can be used by other bus devices. The state of the attention (ATN) line is controlled by the calculator and determines how the data lines are interpreted. The ATN line is constantly monitored by the 6002A and all other bus devices. When ATN is true, the bus devices interpret the data on lines D101-D108 as instructions (commands) from the calculator. Assume that a command is sent (ATN line true) enabling the 6002A to listen in preparation to receive data from a "talker" (in this case the calculator). The address switches were previously set to a particular address (one of 31 address codes) that distinguishes the 6002A from the other bus devices. After addressing the 6002A to listen, the calculator places the HP-IB in the data mode by setting the ATN line false and transfers data (one character at a time) to the 6002A. The option 001 circuitry in the 6002A buffers the data and converts it to an analog voltage ( $V_{OUT}$ ) which voltage programs the CV or CC output of the power supply. The mode switches are set to CV or CC in order to program the output of the supply.

**A-9** A 3-wire handshake sequence is used to control the transfer of each character on the HP-IB. This process allows devices with different input/output speeds to be interconnected to the HP-IB. The character transfer rate automatically adjusts to the slowest device. The 3-wire handshake lines are designated: DAV (data valid), NRFD (not ready for data), and NDAC (data not accepted). Option 001 includes acceptor handshake circuitry that implements the 3-wire handshake sequence. The 6002A-001 transfer rate is approximately 17 $\mu$ sec per character. The 6002A is programmed by a data word consisting of four characters (digits), thus, a data word is transferred to the 6002A in approximately 68 $\mu$ secs.

**A-10** Option 001 responds to the interface clear (IFC) control signal from the calculator. The IFC signal is used to terminate activity on the HP-IB. Option 001 circuitry does not respond to the remote enable (REN) or EO1 (end or identify) control signals nor does it generate the service request (SRQ) control signal.

### A-11 HP-IB Capabilities

**A-12** As described above, the 6002A-001 has "listener" and "acceptor handshake" HP-IB functional capabilities. The 6002A-001 does not have: Controller, talker, source handshake, service request, device clear, device trigger, extended listener, extended talker, parallel poll, and remote/local HP-IB functional capabilities. All HP-IB functional capabilities are defined in IEEE Standard 488-1975. Table

A-1 lists the specifications concerning operation of the 6002A-001 on the HP-IB.

Table A-1. Option 001 Specifications

<b>OPTION 001 LOGIC LEVELS:</b>		
<u>TTL Logic</u>	<u>CMOS Logic</u>	
1 = true $\geq 2V$	1 = true $\geq 3.5V$	
0 = false $\leq 0.8V$	0 = false $\leq 1.5V$	
<b>ISOLATION:</b>		
250Vdc between HP-IB data input levels and power supply. Option 001 employs TTL logic on HP-IB side of isolators and CMOS logic on power supply side of isolators.		
<b>PROGRAMMING:</b>		
<b>Range:</b>		
High Range – 0 to 50V (CV) or, 0 to 10A (CC)		
Low Range – 0 to 10V (CV) or, 0 to 2A (CC)		
<b>Speed:</b> Typical time for power supply output voltage to change between 0 to 99% or 100% to 0.1% of maximum rated output voltage under programming conditions shown.		
UP: No Load – 100msec Full Load – 100msec		
DOWN: No Load – 400msec Full Load – 200msec		
<b>Accuracy:</b> ( $25 \pm 5^\circ C$ after 30 minute warmup)		
<u>Range</u>	<u>CV</u>	<u>CC</u>
High	0.2% + 25mV	0.2% + 25mA
Low	0.2% + 10mV	0.2% + 25mA
<b>Resolution:</b>		
<u>Range</u>	<u>CV</u>	<u>CC</u>
High	50mV	10mA
Low	10mV	2mA
<b>INTERCONNECTING CABLE (6002A-to-HP-IB):</b>		
Standard 72-inch (1.8 meters) HP-IB cable No. 10631B, supplied with calculator I/O card.		
<b>CONNECTOR:</b>		
HP-IB connector (24-pins) is located on the rear of the 6002A-001.		
<b>TEMPERATURE RANGE:</b>		
Operating: $0^\circ$ to $55^\circ C$		
Storage: $-40^\circ$ to $+75^\circ C$		

## A-13 INSTALLATION DATA

### A-14 Equipment Required

A-15 If an HP calculator is used to program the 6002A-001, the following equipment is required:

HP *** Calculator	I/O Card Package	ROM
9820A	59405A Option 020* HP-IB I/O	Math
9821A	59405A Option 021* HP-IB I/O	Math
9825A	98034A HP-IB I/O	String, General I/O, Extended I/O
9830A	59405A Option 030 ** HP-IB I/O	String

- \* Includes Peripheral Control II ROM
- \*\* Includes Extended I/O ROM
- \*\*\* If the HP-IB/21MX minicomputer is used as the controller, the 59310B HP-IB Computer Interface card is required.

### A-16 HP-IB Connector

A-17 The HP-IB connector on the rear of the 6002A-001 interfaces directly to the HP-IB. Figure A-2 illustrates the pin configuration of the HP-IB connector which is a 24-pin, type 57 micro-ribbon connector. One HP-IB cable is supplied with each HP computer and calculator I/O card package. Extra cables may be ordered separately.

HP-IB Cable Model No.	Cable Length
10631A	1m (3.3 ft.)
10631B	2m (6.6 ft.)
10631C	4m (13.2 ft.)

#### NOTE

The HP-IB connector supplied with this unit contains metric fasteners (colored black). If your HP-IB cable connector contains standard mating screws (silver), make a conversion using the hardware and instructions included in Metric Conversion Kit (5060-0138) supplied with this Option.

A-18 The HP-IB cables use the same piggyback connector

on both ends. The connectors may be stacked one upon another. As many as 15 instruments (including the controller) may be connected to the same HP-IB. Figure A-3 illustrates a controller (e. g., a 9830A calculator) and a 6002A-001 power supply connected to the HP-IB.

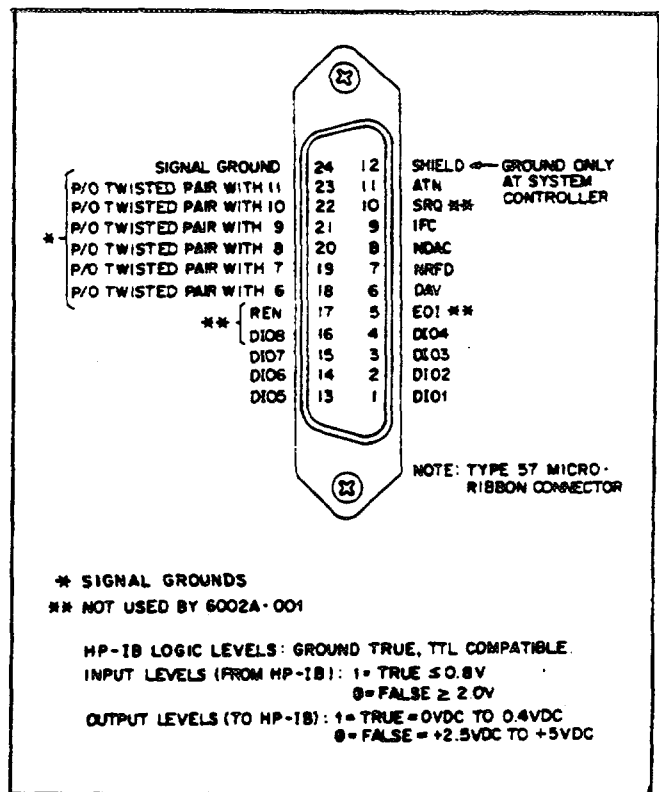

Figure A-2. HP-IB Connector

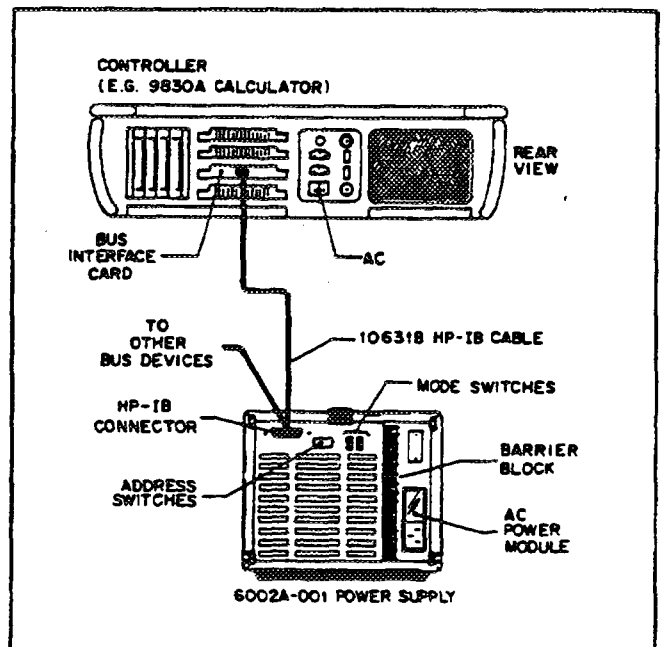

Figure A-3. HP-IB Cable Connections

## A-19 Setting Address

A-20 The listen address for the 6002A-001 DC Power Supply is selected by address switches on the rear of the unit. The switches are factory set to the suggested listen address of % when the unit is shipped from the factory. As shown in Figure A-4, there are seven address switches. The last two switches (6 and 7) are ignored (have no affect). Switches 2, 4, and 5 are set to "0" and switches 1 and 3 are set to "1" to select a listen address of "%". Note that "%" is the suggested listen address and is one of 31 listen address possibilities. The address switch settings for each of the 31 listen address possibilities are listed in Table A-2.

A-21 The HP-IB bus interface cards for the HP calculators are shipped from the factory with a preset talk address of "U" and a preset listen address of "5". Before programming, write down the listen and/or talk addresses of all instruments connected to the HP-IB.

## A-22 Mode Switches

A-23 The CV/CC/LOCAL mode switches, located on the rear of the 6002A-001, consist of a pair of push-in, push-out type switches as shown in Figure A-4. The positions of these switches determine if the power supply is programmed via the HP-IB or if it is controlled locally by the front panel VOLTAGE and CURRENT potentiometers. When programming the supply via the HP-IB, the switches are set to the CV or CC positions (one switch in, the other switch out) depending upon the user's requirements. The option 001 circuits are factory adjusted for CV operation. If CC operation is required, the circuits must be readjusted as described in paragraph A-108. When CV is selected, the supply's CV output is programmed via the HP-IB (front panel VOLTAGE potentiometer has no control) and the CC output is controlled locally by the front panel CURRENT potentiometer (or via remote programming terminals A4 and A6, see paragraphs 3-44 through 3-46). When CC is selected, the supply's CC output is programmed via the HP-IB (front panel CURRENT potentiometer has no control) and the CV output is controlled locally by the front panel VOLTAGE potentiometer (or

Table A-2. Listen Addresses and Switch Settings

Address Switches					Listen Address Character
5	4	3	2	1	
0	0	0	0	0	SP
0	0	0	0	1	!
0	0	0	1	0	"
0	0	0	1	1	=
0	0	1	0	0	\$
0	0	1	0	1	%
0	0	1	1	0	&
0	0	1	1	1	'
0	1	0	0	0	(
0	1	0	0	1	)
0	1	0	1	0	*
0	1	0	1	1	+
0	1	1	0	0	,
0	1	1	0	1	-
0	1	1	1	0	.
0	1	1	1	1	/
1	0	0	0	0	0
1	0	0	0	1	1
1	0	0	1	0	2
1	0	0	1	1	3
1	0	1	0	0	4
1	0	1	0	1	5
1	0	1	1	0	6
1	0	1	1	1	7
1	1	0	0	0	8
1	1	0	0	1	9
1	1	0	1	0	:
1	1	0	1	1	;
1	1	1	0	0	<
1	1	1	0	1	=
1	1	1	1	0	>

via remote programming terminals A2 and -S, see paragraphs 3-39 through 3-43). If the mode switches are set to LOCAL (both switches out), the front panel VOLTAGE and CURRENT potentiometers (or remote programming resistance/voltage) control operation and there is no control via the HP-IB. Operating the supply in the CV or CC mode is described in paragraphs A-43 through A-54.

### NOTE

Programming via the HP-IB is allowed in the CV or CC mode but not in both modes simultaneously. If both switches are inadvertently pushed in (CV and CC both selected), the output of the supply is held near zero and there is no control from either the front panel controls or the HP-IB.

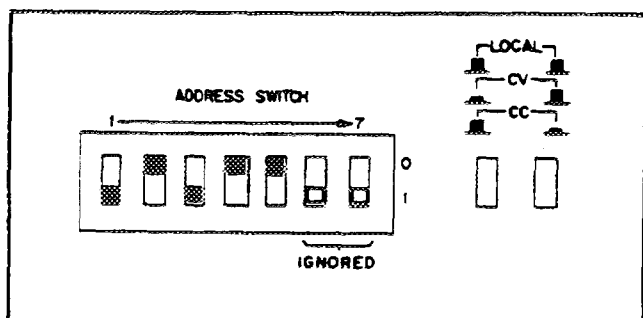
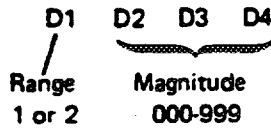

Figure A-4. Listen Address and Mode Switches



## A-24 PROGRAMMING

**A-25** The CV or CC output of the power supply is programmed by a data word comprised of four ASCII characters (digits) received in the order shown below. The first digit specifies range and the next three digits specify the desired magnitude (% of full scale). The range digit can be the number 1 to specify low range (10V for CV, 2A for CC) or the number 2 to specify high range (50V for CV, 10A for CC). The magnitude digits can be any number from 000 to 999.



**A-26** Option 001 is basically a digital-to-analog converter (DAC) that voltage programs the power supply's CV or CC output in the high or low range. The DAC automatically provides a voltage programming output to the power supply as soon as four digits are received. This output is retained until the next four digits are received. The DAC is programmed by the magnitude digits in BCD in such a way that 000 equal 00.0% of full range, 500 equals 50.0% of full range, and 999 equals 99.9% of full range. Since 999 is the maximum value for the magnitude digits, the programmable output ranges are as follows:

- Low Range CV — 0 to 9.99V (99.9% of 10V)
- High Range CV — 0 to 49.95V (99.9% of 50V)
- Low Range CC — 0 to 1.998A (99.9% of 2A)
- High Range CC — 0 to 9.99A (99.9% of 10A)

The following table gives examples of power supply outputs and corresponding data word values.

Power Supply Output	Range	Magnitude %	Data Word Value
2.5V	10V	25.0%	1250
8.94V	10V	89.4%	1894
25.5V	50V	51.0%	2510
40.10V	50V	80.2%	2802
1.50A	2A	75.0%	1750
4.32A	10A	43.2%	2432

### A-27 Calculating Data Word Values

**A-28** Data word value calculations for the 10V, 50V, 2A, and 10A output ranges are described below. Note that each data word must be exactly four digits long (one digit for range and three digits for magnitude).

**A-29** **10V Range.** The desired output voltage values are from 0V to 9.990V. To convert the desired output voltage into a data word representing a percentage of the

output range, proceed as follows:

1. The resolution in the 10V range is 10mV,  
Let  $D = .01$
2. The range digit is 1 for the 10V range, so add 1 to the left end of the 3 magnitude digits,  
Let  $R = 1000$
3. The magnitude portion is calculated by dividing the desired output voltage (V) by the least significant digit D. The magnitude portion must be rounded off to exactly 3 digits,

$$\text{INT}(V/D + 0.5) = 3 \text{ magnitude digits}$$

4. Combine range and rounded off magnitude portion to obtain the correct data word value (N),

$$N = R + \text{INT}(V/D + 0.5)$$

Example, desired voltage = 5.1234 volts

$$D = .01$$

$$R = 1000$$

$$N = 1000 + \text{INT}(5.1234/.01 + 0.5)$$

$$N = 1000 + \text{INT}(512.34 + 0.5)$$

$$N = 1000 + \text{INT}(512.84)$$

$$N = 1000 + 512$$

$$N = 1512 = \text{data word value}$$

In this example, the desired output voltage is 5.1234 volts but the actual power supply output is 5.12V because the resolution is 10mV (least significant digit equals .01). The 10V range calculations are included in the sample programs given in paragraph A-41.

**A-30** **50V Range.** The desired output voltage values are from 0V to 49.95V. The calculations are the same as for the 10V range, except resolution is 50mV and the high range is used. For the 50V range,

$$\text{Let } D = .05,$$

$$\text{and } R = 2000$$

**A-31** **2A Range.** The desired output current values are from 0A to 1.998A. The calculations are the same as for the 10V range, except resolution is 2mA and substitute I for V where I = desired output current. For the 2A range,

$$\text{Let } D = .002,$$

$$\text{and } R = 1000$$

**A-32** **10A Range.** The desired output current values are from 0 to 9.990A. The calculations are the same as for the 10V range, except resolution is 10mA, the high range is used, and substitute I for V, where I = desired output current. For the 10A range,

$$\text{Let } D = .01,$$

$$\text{and } R = 2000$$

### A-33 Sending Data Words

**A-34** Before a data word is sent, a command must be issued establishing the controller as the "talker" and the 6002A-001 power supply as the "listener". The following

examples assume that the controller (9830A or 9825A calculator) has been assigned its standard talk and listen address of "U" and "5" respectively, and the 6002A-001 has been assigned a listen address of "%".

A-35 Example 1 illustrates a command statement (9830A calculator) containing the proper talk and listen addresses. The statement includes the constant data word value "1250" which is sent to the 6002A-001.

**Example 1. Sending a Constant Data Value (9830A Calculator)**

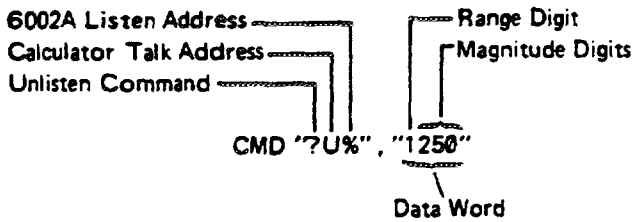

A-36 Example 2 illustrates a command statement issued by a 9825A calculator. Note that in addition to the calculator talk address "U" and the 6002A-001 listen address "%", the address code of the HP-IB Interface Card (98034A) must be included. It is assumed that the interface card has been assigned its standard select code of "7". The 9825A command statement also includes a constant data value of "1250" which is sent to the 6002A-001.

**Example 2. Sending a Constant Data Value (9825A Command Statement)**

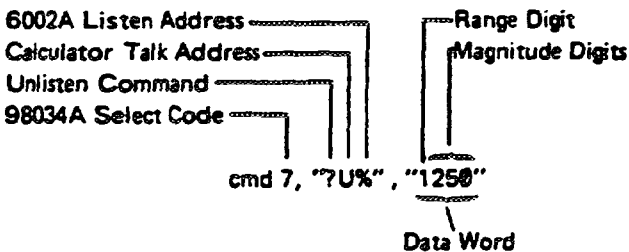

A-37 Example 3 illustrates a write statement (9825A calculator) which can also be used to address the 6002A-001 to listen and send a constant data value. The 6002A-001 listen address of "%" corresponds to an address of "05" as defined in the 9825A General I/O ROM manual (09825-90024) Chapter 4. Note the format statement (line 0) used in Example 3. The "c" specifies a character field, while the "z" is used to suppress carriage return/line feed codes at the end of the write statement. Suppression of the carriage return/line feed codes is essential when programming the 6002A-001. If they are not suppressed, they will be processed as data characters by option 001 resulting in an undesired power supply output.

**Example 3. Sending a Constant Data Value (9825A Write Statement)**

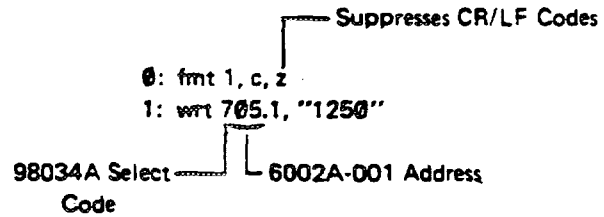

A-38 Command statements can only be used to send data constants. Output (9830A) or write (9825A) statements can also be used to send data constants but must be used to send variables.

A-39 Example 4 illustrates how an output statement (9830A) is used to send variable data to the 6002A-001. This example includes a command statement (line 100) enabling the 9830A to talk and the 6002A-001 to listen. However, the variable data that will be sent to the 6002A-001 is included in the output statement (line 120). Variable N can be any number from 1000 to 1999 or from 2000 to 2999. If the variable were equal to 1250, Example 4 would program the same power supply output as Example 1. Note that in Example 4, line 110 uses format specification F1005.0 and line 120 ends in a semi-colon. The F1005.0 format specification deletes leading spaces from the output data item and specifies a field width of four digits (space for + sign is suppressed) with no decimal places. The use of the semi-colon (line 120) suppresses the carriage return/line feed codes at the end of the output statement. If the leading spaces are not deleted and the CR/LF codes are not suppressed the power supply output will go to an undesired value.

**Example 4. Sending Variable Data (9830A Calculator)**

```
100 CMD "?U%"
110 FORMAT F1005.0
120 OUTPUT (13,110) N;
```

A-40 Example 5 illustrates how a write statement (9825A) is used to send variable data to the 6002A-001. If variable N in line 1 were equal to 1250, this example would program the same power supply output as the previous examples. Format specification f4.0 deletes leading spaces and the z suppresses the CR/LF codes for the same reasons as described above.

**Example 5. Sending Variable Data (9825A Calculator)**

```
0: fmt 1, f4.0, z
1: wrt 705.1, N
```

## A-41 Sample Programs

A-42 Sample programs using the 9830A and 9825A calculators are given in Examples 6 and 7, respectively. The programs allow keyboard input of the desired power

supply voltage. Depending upon the voltage value entered, the programs automatically select the proper range constants to calculate the correct data word. The programs can easily be modified to input current by substituting I (current) for V (voltage) and using the current limits and resolution values given in paragraphs A-31 and A-32.

### Example 6. 9830A Sample Program

```
10 REM THIS PROGRAM OUTPUTS TO HP-IB POWER SUPPLY INTERFACE
20 REM VOLTAGE INPUT IS IN VOLTS
30 REM VARIABLE ASSIGNMENTS ARE AS FOLLOWS:
40 REM V VOLTAGE TO BE PROGRAMMED
50 REM D THE VALUE OF A LEAST SIGNIFIGANT DIGIT
60 REM R CONSTANT TO DETERMINE RANGE; 1000=LOW RANGE, 2000=HIGH RANGE
70 REM N THE PROGRAM CODE THAT IS OUTPUT TO THE POWER SUPPLY
80 CMD "90"
90 FORMAT F1005.0
100 DISP "ENTER VOLTAGE (0 TO 50 VOLTS)";
110 INPUT V
120 IF V >= 0 THEN 150
130 DISP "ENTER POSITIVE VOLTAGE ONLY";
140 GOTO 110
150 IF V <= 50 THEN 180
160 DISP "VOLTAGE TOO HIGH, REENTER";
170 GOTO 110
180 IF V#50 THEN 200
190 LET V=49.95
200 IF V>9.995 THEN 240
210 LET D=0.01
220 LET R=1000
230 GOTO 260
240 LET D=0.05
250 LET R=2000
260 N=R+INT(V/D+0.5)
270 CMD "90N"
280 OUTPUT (13,90)N;
290 GOTO 80
300 END
```

#### Explanation:

- 10-200 Allow user to input desired voltage on 9830A keyboard. Automatically select proper range and corresponding section of program. Format specification F1005.0 in line 90 deletes leading spaces (see paragraph A-39).
- 210-260 Calculate the correct data word value (N) for output to the 6002A-001. Lines 210 and 220 provide low range constants while lines 240 and 250 provide high range constants.
- 270 9830A is addressed (U) to talk and 6002A-001 is addressed (%) to listen.
- 280 Data word (N) is sent to the 6002A-001. Semi-colon at end of output statement suppresses the CR/LF codes (see paragraph A-39).
- 290 Program returns to line 80 allowing user to input the next desired output voltage value.

### Example 7. 9825A Sample Program

```
0: "start":ent "Enter Voltage (0 to 50V)":V
1: if V<0:ent "Enter Positive Voltage":V:jmp 0
2: if V>50:ent "Voltage Too High: Reenter":V:jmp -1
3: if V=50:49.95→V
4: .01→D:1000→R:if V>9.995: .05→D:2000→R
5: R→int (V/D+.5)→N
6: fmt 1:f4.0:z:ent 785.1:N:eto "start"
7: end
```

#### Explanation:

- 0-2 User inputs desired voltage on 9825A keyboard.
- 3-4 Proper constants are selected for high or low range.
- 5 Correct data word value (N) is calculated.
- 6 Data word (N) is sent to the 6002A-001. Format f4.0 deletes leading spaces and z suppresses the CR/LF codes (see paragraph A-40). Program returns to line 0 (start) allowing the user to input the next desired voltage value.

## A-43 OPERATING INSTRUCTIONS

A-44 The following paragraphs provide operating instructions required to program the supply for constant voltage or constant current operation. A brief description of Option 001 control of the CV/CC circuits within the supply is also provided.

### A-45 Constant Voltage Operation

A-46 To program the supply for constant voltage operation:

- a. Connect supply to an HP-IB controller.
- b. Set Mode switches on rear of supply to CV position.
- c. Turn on controller and supply
- d. With the supply's output terminals open, program the supply for the desired output voltage.
- e. Connect a short across the supply's rear panel output terminals and adjust the front panel CURRENT control for the desired maximum output current. If a load change causes this current limit to be exceeded, the supply automatically crosses over to constant current operation at this preset current limit and the output voltage drops proportionally.

### A-47 Constant Current Operation

A-48 To program the supply for constant current operation:

- a. Adjust option 001 for CC operation as described

in paragraph A-108.

- b. Turn off supply and connect a short across the rear output terminals.
- c. Set Mode switches to CC and turn on the supply.
- d. Program the supply for the desired output current.
- e. Open the output terminals and adjust the front panel VOLTAGE control for the desired maximum output voltage. If a load change causes this voltage limit to be exceeded, the supply automatically crosses over to constant voltage operation at this point voltage limit and the output current drops proportionally.

## A-49 CV/CC Control Circuits

A-50 The Option 001 circuits produce a voltage programming output in response to the digital data received on the HP-IB. As shown in Figure A-5, the programming voltage ( $V_{OUT}$ ) is applied to the CV or CC control circuits within the supply through the mode switches. The magnitude of  $V_{OUT}$  ranges from 0 to  $-6.20V$  nominal (with respect to  $\nabla$ ) for high range programming codes (2000 to 2999) and from 0 to  $-1.24V$  (nom) for low range programming codes (1000 to 1999). In the CV mode, the positive side ( $\nabla$ ) of the programming voltage is substituted for the  $+6.2V$  reference in the CV comparison amplifier circuit to control the supply's output voltage. In the CC mode, the negative side ( $V_{OUT}$ ) of the programming voltage is substituted for the fixed  $-6.2V$  reference in the CC comparison amplifier circuit to control the supply's output current.

A-51 Figure A-5 shows CV programming selected (S2

in, S3 out) substituting  $\nabla$  for the +6.2V fixed reference in the CV comparison amplifier circuit. Also, the wiper of VOLTAGE potentiometer R1 is open circuited making it a fixed resistor. For this configuration, changes in the magnitude of the programming voltage ( $V_{OUT}$ ) or any instantaneous changes in the supply's output voltage produce a difference voltage between the + and - inputs of the CV comparison amplifier. This difference voltage is amplified and appears at the amplifier output as an error voltage. The error voltage varies conduction of the supply's series regulator until the output changes sufficiently to hold the difference voltage at zero volts.

**A-52** For CC programming (S2 out, S3 in),  $V_{OUT}$  is substituted for the -6.2V fixed reference in the CC comparison amplifier circuit. Also, the wiper of CURRENT potentiometer R2 is open circuited making it a fixed resistor. For this configuration, changes in the programming voltage ( $V_{OUT}$ ) or instantaneous changes in the output current due to load changes produce a difference voltage between the + and - inputs of the CC comparison amplifier. This difference is amplified and appears at the amplifier output as an error signal. The error signal varies the conduction of the supply's series regulator thus changing the output current until the difference voltage is zero volts.

**A-53** Programming via the HP-IB is allowed in the CV or CC mode but not in both modes simultaneously. If S2 and S3 are inadvertently pushed in at the same time, the output of the supply is held near zero and there is no control from either the front panel controls or the HP-IB.

**A-54** If the mode switches are set to LOCAL (S2, S3 out), the front panel VOLTAGE and CURRENT potentiometers control operation and there is no control via the HP-IB. Note that if the 6002A supply is not equipped with Option 001, the following jumpers are factory installed on the A2 interconnect board:

Jumper	Connection
A2W1	between A2J1 pins 10 and 11
A2W2	between A2J1 pins 12 and 13
A2W3	between A2J1 pins 17 and 18
A2W4	between A2J1 pins 15 and 16

## A-55 CIRCUIT DESCRIPTION

**A-56** Option 001 consists of digital processing circuits, a digital-to-analog converter, and analog output circuits which allow the 6002A power supply to change its output voltage or current in response to the digital data received on the HP-IB. The circuits are functionally separated and included on a series of schematic diagrams, Figure A-15,

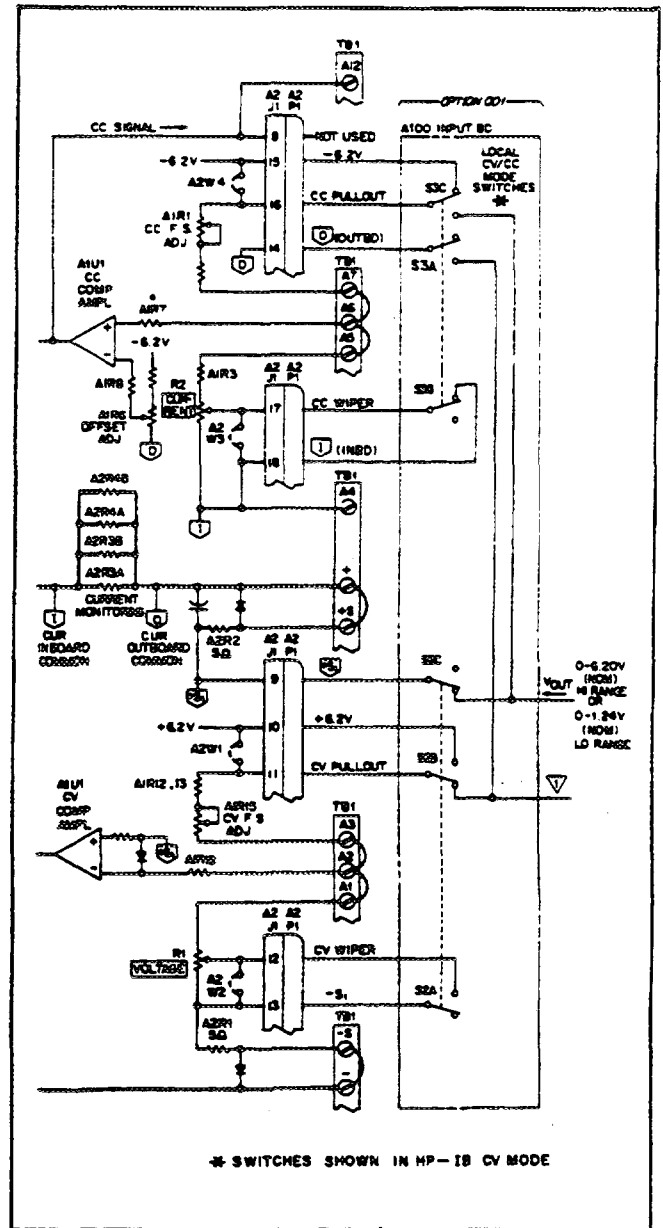

Figure A-5. CV/CC Control Circuits

sheets 1 through 5 at the end of this appendix. The following descriptions are based on the schematics and are presented to support the troubleshooting procedures given in paragraphs A-93 through A-100.

## A-57 A100 Input Board, (Figure A-15, Sheet 1)

**A-58** The input board contains resistor networks, input inverters, and the address comparator circuit. The resistor networks provide the proper terminations for the 16 bus lines. Schmitt trigger input inverters U2 are provided for the  $\overline{D101}$ - $\overline{D106}$  data input lines. The input inverters for data input line  $\overline{D107}$  and bus control signals  $\overline{IFC}$ ,  $\overline{ATN}$ , and  $\overline{DAV}$  are on the A200 board (Figure A-15, Sheet 2).

A-59 The address comparator consists of 5-bit comparator U1 and the address switches on the rear of the supply. When the levels on data lines DI01-DI05 match the address switch settings, U1 provides a HI level ADDRESS output to the listen logic on board A200.

**A-60 A200 Digital Board (Figure A-15, Sheets 2 and 3)**

A-61 Except for the address comparator (A100U1) and input inverters (A100U2), all of the digital processing circuits are contained on the A200 board. Listen logic, acceptor handshake, clock generator, and turn-on preset circuits are shown on sheet 2. Isolators, data storage, data storage sequencer, and the digital-to-analog converter are shown on sheet 3.

A-62 Turn-On Preset (Sheet 2). When power is initially turned-on, the preset circuit generates a LO level pulse ( $\overline{\text{PON}}$ ) which resets the listen flip-flop (listen logic), the accept data flip-flop (acceptor handshake), and the data storage sequencer. Thus, the preset circuit ensures that the 6002A is not a "listener" and is properly initialized when power is turned-on.

A-63 Acceptor Handshake (Sheet 2). The acceptor handshake circuit implements the 3-wire handshake cycle that occurs with each command or data character received on the bus data lines DI01-DI07. Unrecognized command characters (e. g., talk address) will be ignored but the handshake cycle between the controller and the 6002A will occur anyway. The 3-wire handshake lines are designated  $\overline{\text{DAV}}$  (data valid),  $\overline{\text{NRFD}}$  (not ready for data), and  $\overline{\text{NDAC}}$  (data not accepted). The acceptor handshake circuit is enabled when the bus is in the command mode ( $\overline{\text{ATN}}$  is LO) or if the 6002A is in the listen mode (listen flip-flop set) and  $\overline{\text{ATN}}$  is HI (data mode). For either of the above conditions, the output of NAND gate U7-6 goes HI and NAND gate U1-11 goes LO enabling the acceptor handshake circuits. Figure A-6 illustrates the 3-wire handshake cycle timing sequence for each character received by the 6002A in the command and data modes.

$T_0$ : Initially the  $\overline{\text{NRFD}}$  signal (J1-7) is HI (6002A is ready for data) and the  $\overline{\text{NDAC}}$  signal (J1-8) is LO (data not accepted). Also  $\overline{\text{DAV}}$  (J1-6) is HI (data on bus is not valid).

$T_1$ : The source (assume controller) puts a character on the bus and indicates that the character is valid by setting  $\overline{\text{DAV}}$  (J1-6) LO.

$T_2$ : After a delay of approximately 1 $\mu\text{sec}$   $\overline{\text{NRFD}}$  goes LO (6002A not ready for data). Also, accept data signals, ACDS (U13-13) and ACDS (U13-4), are generated.

a. If the HP-IB is in the command mode ( $\overline{\text{ATN}}$  LO), the ACDS signal gates a recognized command character (6002A's listen address of "%" or unlisten command "?") which sets or resets the listen flip-flop (see paragraph A-64).

b. If the HP-IB is in the data mode ( $\overline{\text{ATN}}$  HI) and the 6002A had previously been addressed to listen, the ACDS signal gates the clock generator, producing a clock pulse which loads the data character (range or magnitude) present on bus lines (DI01-DI04) into the appropriate storage register (see paragraph A-66).

$T_3$ : After approximately 15 $\mu\text{sec}$ , the trailing (positive) edge of the ACDS (U13-4) signal produces a negative pulse (U8-11) which sets the DAC F/F (U7-8 goes HI and U10-8 goes LO). With U10-8 LO,  $\overline{\text{NDAC}}$  (J1-8) goes HI indicating that the 6002A has accepted the data.

$T_4$ : The controller sensing  $\overline{\text{NDAC}}$  HI, sets  $\overline{\text{DAV}}$  HI indicating that the data on the bus is no longer valid.

$T_5$ : When  $\overline{\text{DAV}}$  goes HI, the  $\overline{\text{DAV}}$  F/F is reset (U10-8 goes HI and U7-8 goes LO) causing  $\overline{\text{NDAC}}$  (J1-8) to go LO (data not accepted). Also, with  $\overline{\text{DAV}}$  HI,  $\overline{\text{NRFD}}$  goes HI indicating that the 6002A is ready for the next character.

$T_6$ : With  $\overline{\text{NRFD}}$  HI, the controller sets  $\overline{\text{DAV}}$  LO and the next character is transferred (T2 through T5).

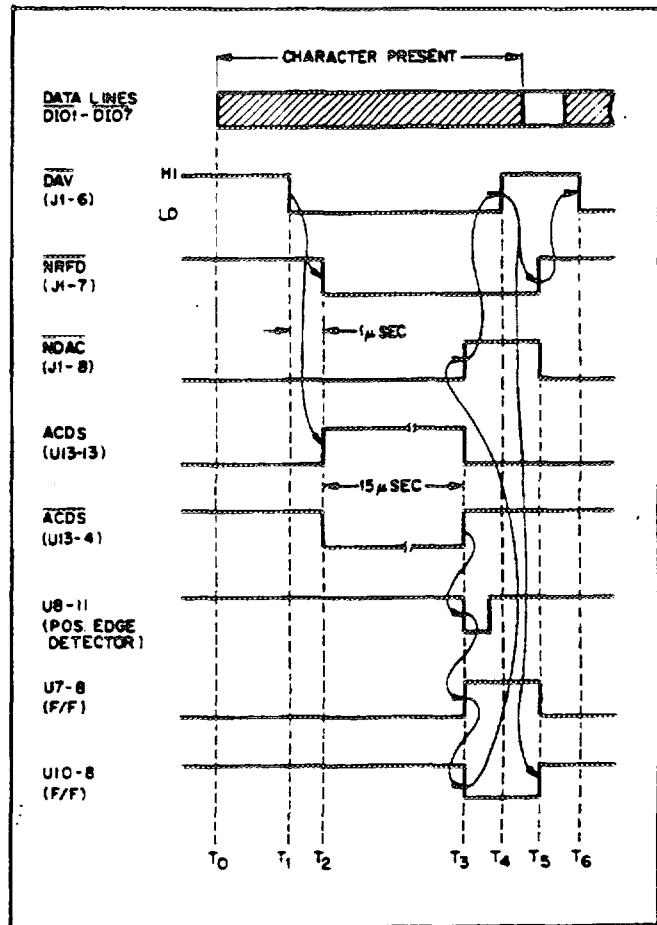

Figure A-6. Acceptor Handshake Signals, Timing Diagram

**A-64 Listen Logic (Sheet 2).** The listen logic consists of logic gates which set or reset the listen flip-flop. When the listen flip-flop is set, the 6002A is enabled to function as a "listener" on the HP-IB. When the listen flip-flop is reset, the 6002A is inhibited from functioning as a "listener". The listen logic is enabled when the HP-IB is in the command mode ( $\overline{ATN}$  is LO). If  $\overline{ATN}$  is LO and the 6002A's listen address is decoded (ADDRESS is HI), the listen flip-flop is set (U8-3 goes HI) when ACDS is received from acceptor handshake circuit. Note that only a portion of the listen address is specified by the ADDRESS signal. In addition, HP-IB data input line  $\overline{D107}$  must be HI and line  $\overline{D106}$  must be LO to specify that a listen address is present on the bus. With the listen flip-flop set, the clock generator will be enabled when the bus is placed in the data mode ( $\overline{ATN}$  goes HI). The clock generator produces clock pulses which gate the data sequencer storing the data characters received on the bus (see paragraph A-66).

**A-65** If the  $\overline{ATN}$  line goes LO again (command mode) and an unlisten command (ASCII "?"") is placed on the bus, the listen flip-flop is reset (U8-3 goes LO) when ACDS is received, inhibiting the clock generator and resetting the data sequencer. Note that the interface clear ( $\overline{IFC}$ ) signal also resets the listen flip-flop. The  $\overline{IFC}$  signal is used by the controller to terminate activity on the bus.

**A-66 Clock Generator (Sheet 2).** The clock generator is enabled when the listen flip-flop is set (U8-3 is HI) and the HP-IB is in the data mode ( $\overline{ATN}$  is HI). When enabled, the clock generator produces a clock pulse (approximately 4 $\mu$ sec wide) on the leading edge of the ACDS signal received from the acceptor handshake circuit. The clock pulse gates the data storage sequencer which loads the data on lines  $\overline{D101}$ - $\overline{D104}$  into the appropriate storage latch (see paragraph A-68).

**A-67 Isolators (Sheet 3).** Data bits  $\overline{D101}$ - $\overline{D104}$ , the sequencer clock signal, and the sequencer reset signal are applied through inverter drivers (U4-U5) to photo-isolators (U15, U16, U17). The inputs to the isolators are referenced to bus ground  $\nabla$  while the outputs are referenced to power supply ground  $\nabla$ . With these input and output connections, up to 250Vdc isolation is provided between the HP-IB data input lines and the 6002A power supply. Each dual isolator IC package contains a pair of light emitting diodes and integrated photon detectors. The isolated  $\overline{D101}$ - $\overline{D104}$  data bits are routed to the appropriate data 1 storage latches while the isolated clock and reset signals are sent to the data storage sequencer.

**A-68 Data Storage (Sheet 3).** The data storage circuits consist of data storage 1 latches, data storage 2 latches, and the data storage sequencer circuit. The circuits store the data word which consists of four characters. The

characters are transferred from the bus one at a time with the range character transferred first followed by the three magnitude characters. Each character, bits  $\overline{D104}$  (MSB) -  $\overline{D101}$  (LSB), is transferred into data storage 1 during the accompanying 3-wire handshake cycle. After the fourth character is transferred into data storage 1, all four characters (data word) are automatically loaded into the data storage 2 latches. The timing sequence for the data word transfer is provided in Figure A-7.

**A-69** The leading edge of each ACDS pulse generates a clock pulse which gates the data storage sequencer. Initially, the data shift register (U28) in the data storage sequencer is reset and the data input (U28-7) is a HI level. The timing sequence that occurs during the transfer of a data word is described below (Refer to Figure A-7).

- a. Cycle 1. The first clock pulse produces a negative pulse (L1) at U18-8. The trailing edge of L1 loads the range character into data storage 1 (U27, J/K flip-flop). The trailing edge of the first clock pulse transfers the data input (U28-7) into the shift register causing Q1 (U28-5) to go HI. With Q1 HI, the L2 AND gate (U19-8) is enabled. Also with Q1 HI, the data input (U28-7) goes LO.
- b. Cycle 2. The second clock pulse produces a positive pulse L2 at U19-10. While U2 is HI, the first magnitude character is transferred into data storage 1 (U26, four bit latch). The trailing edge of the second clock pulse causes U28 to shift (Q1 goes LO, Q2 goes HI). With Q2 HI, the data input (U28-7) remains LO and the L3 AND gate (U19-5) is enabled.
- c. Cycle 3. The third clock pulse produces a positive pulse L3 at U19-4. While L3 is HI, the second magnitude character is transferred into data storage 1 (U25, four bit latch). The trailing edge of the third clock pulse shifts U28 (Q2 goes LO, Q3 goes HI). With Q3 HI, data input remains LO and the L4 AND gate (U19-1) is enabled.
- d. Cycle 4. The fourth clock pulse produces a positive pulse L4 at U19-3. While L4 is HI, the third magnitude character is transferred into storage level 1 (U24, four bit latch). The trailing edge of the fourth clock pulse shifts U28 (Q3 goes LO, Q4 goes HI). When Q4 goes HI, the range character and the three magnitude characters are loaded into the data storage 2 latches (U27 and U21-U23). The Q4 HI transition also causes U28-13 (P/O turn on/off circuit) to go HI (this signal is significant only when power is initially applied and the first data word is loaded, see paragraph A-81). The Q4 output is fed back to the shift register input (U28-6) through OR gate U20 and delay circuit (C3, R23) resetting the shift register (Q1-Q4).

outputs to go LO). For this condition, the data input (U28-7) is HI initializing the shift register for the next data word transfer.

**A-70** The range latch output (U27-14) is LO if high range was programmed and HI if low range was programmed. The range output controls the range switch on the A300 analog board (see paragraph A-78).

**A-71** The outputs of 4-bit storage latches U21-U23 are applied to the digital-to-analog converter (DAC) U29. The DAC is programmed in BCD. Each 4-bit storage latch contains a number (0-9). Thus, the three latches can provide an output from 000-999. The latch outputs are connected to the DAC input in the proper order (i. e., U23 contains the

most significant bits, etc.). The data storage 2 outputs are retained until a new data word is transferred from the bus.

**A-72** **Digital-to-Analog Converter (Sheet 3).** The digital-to-analog converter (DAC) U29 converts the 12-bit BCD input into an output current. The DAC OUT range (0-2mA) corresponds to a BCD input range of 000-999. The DAC OUT is applied to a current-to-voltage converter (Operational Amplifier A300U1) on the Analog Board. The outputs of A300U1 is connected to pin 10 (10V SPAN R) of the DAC to obtain an output range of from 0-10V.

**A-73** **A300 Analog Board (Figure A-15, Sheets 4 and 5)**

**A-74** The analog board contains the analog output circuits and dc power supplies which provide the operating voltages for the Option 001 circuitry. The analog circuits are shown on sheet 4 which also illustrates the LOCAL/CV/CC mode switches (part of the A100 Input Board) and the connections to the power supply's A2 interconnect board. Sheet 5 illustrates the dc power supplies and power distribution for the Option 001 circuit boards.

**A-75** **Analog Output Circuits (Sheet 4).** The analog output circuits consist of two operational amplifiers (U1 and U2), the range switch circuit (Q1, Q4), and a turn on/off circuit (Q2, Q3, Q6, and Q7).

**A-76** Operational amplifier U1 functions as a current-to-voltage converter. The 0-2mA input from the DAC is converted to a 0-10V output. Variable resistor R4 provides a zero balance adjustment. The 0-10V output is applied to output amplifier U2 through range resistors R6-R9.

**A-77** Output amplifier U2 provides an output of 0-6.20V in the high range or 0 to 1.24V in the low range. In the high range, resistors R8 and R9 are shunted through range switch FET Q1 (see paragraph A-79). With R8 and R9 shunted, the gain of U2 is equal to  $R_{10} \div (R_6 + R_7)$ . Variable resistor R7 allows full scale adjustment in the high range. In the low range, the gain of U2 is equal to  $R_{10} \div (R_6 + R_7 + R_8 + R_9)$ . Variable resistor R9 allows full scale adjustment in the low range while variable resistor R19 provides a zero output adjustment. The output of U2 (0-6.20V or 0-1.24V) is applied through the mode switches to voltage program the output voltage (CV position) or current (CC position) of the 6002A power supply (as described in paragraphs A-49 through A-54).

**A-78** The range switch allows output amplifier U2 to provide a high range output (0-6.20V) or a low range output (0-1.24V). The range switch circuit (Q1, Q4) receives a RANGE signal level from the range latch (A200U27). A LO signal level represents high range and a HI signal level represents low range.

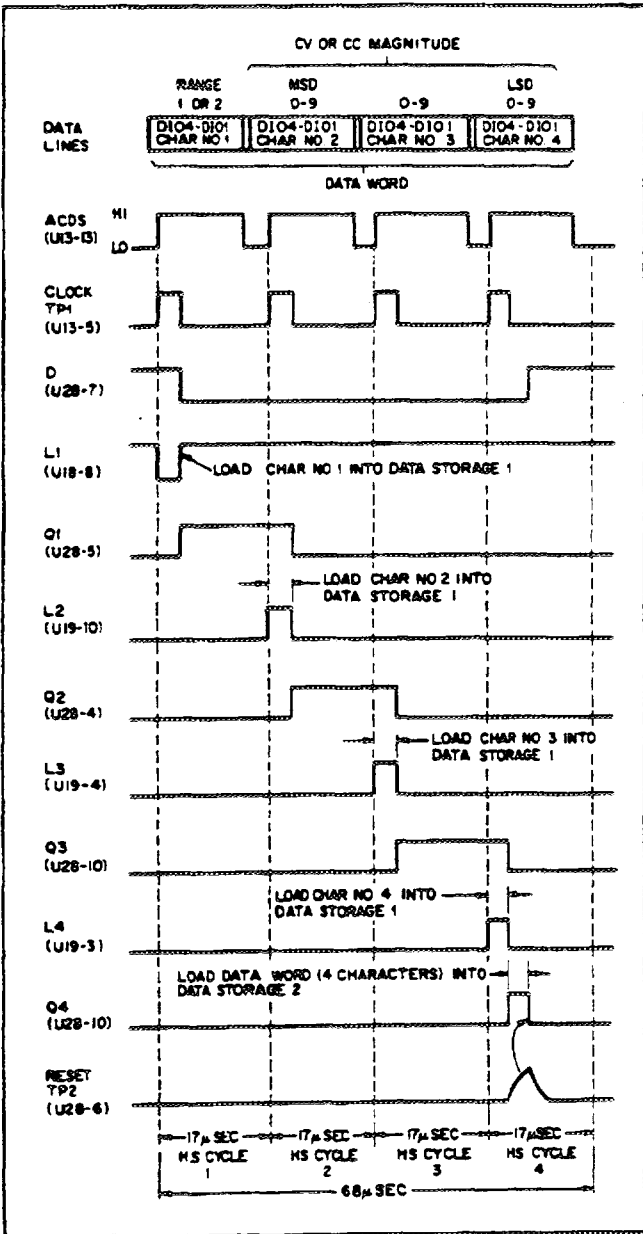

Figure A-7. Data Word Transfer, Timing Diagram



A-79 If a LO level is received, transistor Q4 is turned-off causing FET Q1 to conduct. The FET is used as a switch which has a very low on resistance and a very high off resistance. While conducting, Q1 couples the output of U1 to the input of U2 via range resistors R6 and R7 (R8 and R9 are bypassed).

A-80 If a HI level is received, transistor Q4 is turned-on causing Q1 to turn-off. For this condition, the output of U1 is coupled to the input of U2 through range resistors R6 through R9.

A-81 The turn on/off circuit is comprised of shift register B (U28) on the A200 board (sheet 3), transistor stages (Q6, Q7), and FET's Q2 and Q3 on the A300 board. The purpose of this circuit is to prevent transients at power turn-on and turn-off from affecting the power supply. To accomplish this, the output is clamped at a low level when power is turned on or off.

A-82 Before power is turned-on, FET Q2 provides a short circuit across output amplifier U2 and FET Q3 shorts the amplifier output to ground. When power is turned-on, the Vdd supply voltage (junction R26 and R27) resets U28 (U28-13 goes LO), turning on Q6. With Q6 turned-on, FET's Q2 and Q3 continue to conduct maintaining the short circuits. Note that when power is turned-on, there is a delay before the -15V supply voltage is available, consequently, Q7 is turned off at initial power turn-on. After the delay, Q7 turns-on removing the reset condition at U28. When the first data word is loaded into data storage 2, shift register B output (U28-13) goes HI (see paragraph A-39d) turning off Q6. With Q6 off, the negative voltage from Q7 causes FET's Q2 and Q3 to cutoff removing the short circuits. Output amplifier U2 will now provide an output determined by the programmed data word.

A-83 At turn-off, the -15V supply voltage decays faster than the +15V and Vdd supply voltages. When the -15V supply decays sufficiently, U28 is reset (U28-13 goes LO) turning on Q6. With Q6 turned-on, Q2 and Q3 conduct restoring the short circuits. Thus, the output of U2 is clamped at a low level during the decay of the +15V and Vdd supply voltages.

A-84 **Supply Voltages (Sheet 5).** The supply voltages for the option 001 circuits are generated on the A300 Analog Board. AC power (120Vac, 48-63Hz) from the 6002A power supply is applied to transformer T1 through connector A2P1. The board contains the following supplies:

±15V supply: Voltages are referenced to  $\nabla$  and are distributed to the operational amplifiers and transistors on the A300 board and the DAC on the A200 board.

Vdd bias supply: Developed from the +15V output. Vdd (+5V) is distributed to A200 board IC's on the

$\nabla$  side of the photo-isolators.

+5V supply: Referenced to bus ground  $\nabla$  and is distributed to all A100 board and A200 board IC's on side of the photo-isolators.

## A-85 MAINTENANCE

A-86 The following paragraphs contain checkout, troubleshooting, repair and replacement, and adjustment procedures for the Option 001 circuits. The checkout procedures verify that the Option 001 circuitry is operating properly by checking that it can be programmed by a controller and that it is properly adjusted. The troubleshooting procedures are performed if a malfunction occurs while performing the checkout procedures or during normal operations. The troubleshooting procedures isolate a malfunction to the Option 001 circuitry at the component level or to the 6002A power supply.

## A-87 Test Equipment

A-88 The controller (e. g., 9825A or 9830A calculator), equipped with the appropriate bus interface card, provides all of the signal inputs necessary for checking and troubleshooting the Option 001 circuits. The additional instruments required for troubleshooting are listed in Table A-3.

A-89 If available, Bus System Analyzer HP Model 59401A can be used in place of the calculator when troubleshooting the 6002A-001. The 59401A provides talker, listener, and controller modes of operation. The operating speed of the 59401A varies from one character at a time in the halt mode, to two characters per second in the slow mode, and full HP-IB speed in the fast mode. Thus, the 59401A can be used to exercise the Option 001 circuitry allowing one character at a time to be transferred and checked.

## A-90 Checkout Procedure

A-91 The procedures given in the flow chart of Figure A-8 are used to check operation of the 6002A-001 power supply when it is initially received. If a malfunction is detected during checkout, the procedures determine whether adjustment or troubleshooting is required. The procedures in Figure A-8 provide the following checks:

1. Power supply's output voltage (CV mode) is held near 0V when power is turned-on.
2. Zero output programming accuracy in the low and high ranges.
3. Full scale programming accuracy in the low and high ranges.

A-92 The checkout procedures are performed with the 6002A-001 power supply connected to the HP-IB along with a controller. The mode switches are set to CV and the

Table A-3. Test Equipment Required

Type	Characteristics	Use	Recommended Model
Digital Voltmeter	Accuracy: $\pm 0.004\%$	Precision dc voltage measurements.	HP Model 3462A or 3490A.
Oscilloscope	Bandwidth: dc to 50MHz	Adjust zero output accuracy. Check handshake cycle timing. CMOS logic circuit troubleshooting.	HP Model 180A with 1804A and 1821A plug-ins.
Logic Probe	Impedance: $25\Omega$ , Trigger Thresh: 2.0V and 0.8V (nom) Min. Pulse Width: 10nsec.	TTL logic circuit troubleshooting.	HP 10525T
Resistor	.01 $\Omega$ , 10A, 100mV	CC adjustments	Weston 0042210

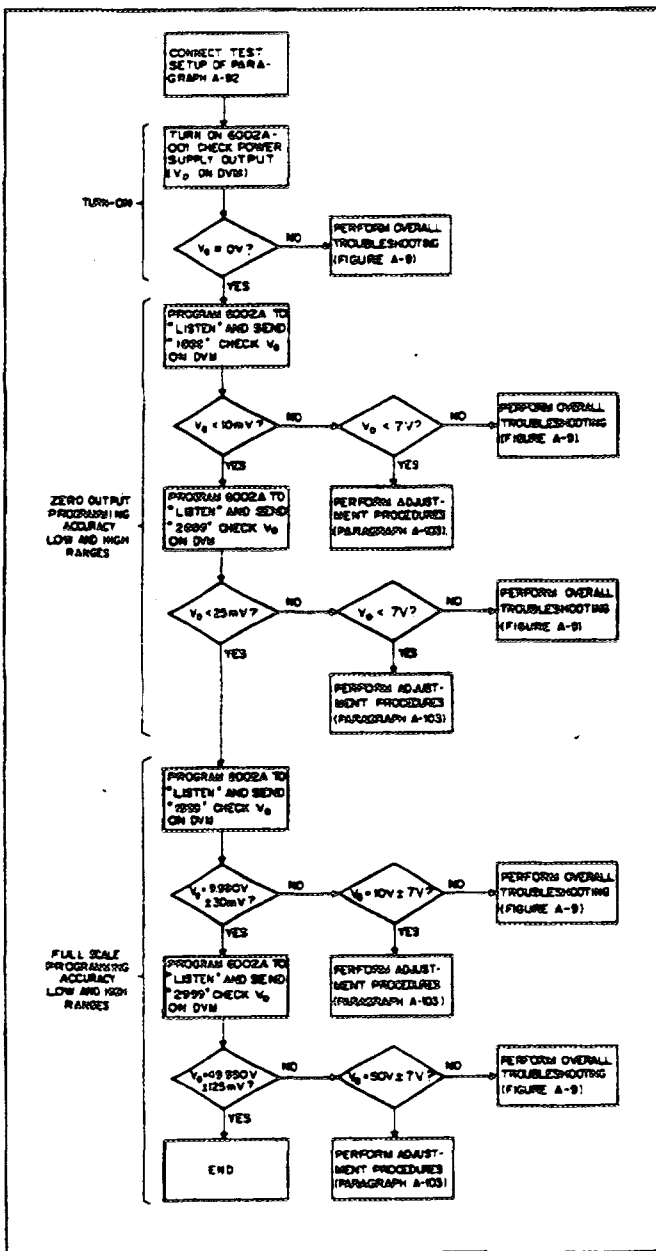

Figure A-8. Checkout Procedures Flow Chart

address switches are set to “%” on the rear of the supply. A DVM is used to monitor the supply’s output voltage. The DVM is connected between the +S and -S terminals on the rear of the supply.

### A-93 Troubleshooting

A-94 The troubleshooting procedures assume that the controller is operating properly and that a malfunction exists in the 6002A-001 power supply. Before attempting to troubleshoot the 6002A-001, it is recommended that the reader review the circuit descriptions provided in paragraphs A-55 through A-84. A good understanding of circuit operation will aid in troubleshooting.

A-95 In order to troubleshoot the 6002A-001, the top cover must be removed from the supply and the Option 001 circuits must be partially disassembled by performing steps a thru c of paragraph A-102.

### WARNING

*Ac power is connected to the A300 board. Exercise extreme caution when working on energized circuits.*

A-96 Overall Troubleshooting. The overall troubleshooting procedures given in Figure A-9 isolate a malfunction to the analog or digital sections of the Option 001 circuitry, or to the 6002A power supply. Separate troubleshooting flow charts are provided for the digital circuits in Figures A-10 and A-11. Complete troubleshooting procedures for the 6002A power supply are provided in Section V.

A-97 The procedures given in Figure A-9 check the Option 001 bias supply voltages first to ensure that these voltages are correct before continuing with the troubleshooting. If the supply voltages are correct, the procedures continue to check if a malfunction is present in the analog or digital portions of the Option 001 circuitry. If a malfunction is not detected, it is assumed that the mode switch, 6002A/Option 001 interconnections, or the 6002A power supply is defective.

The check points listed on Figure A-9 correspond with those on the schematics (Figure A-15, sheets 3 thru 5) and component location diagrams (Figures A-13 and A-14) for the A200 and A300 boards.

**A-98 Digital Circuits Troubleshooting.** The digital circuits troubleshooting procedures given in Figure A-10 isolate a malfunction to components on the A200 or the A100 board. Figure A-10 checks the digital circuits in the following sequence.

1. Turn-on/preset
2. Listen logic
3. Unlisten decoder
4. Clock generator
5. Data input circuits
6. Isolators
7. Data sequencer
8. Data storage

**A-99** The check points and functional circuit areas listed on Figure A-10 correspond with those on the schematics (Figure A-15, sheets 1 thru 3) and component location diagrams (Figures A-12 and A-13) for the A100 and A200 boards.

**A-100 Acceptor Handshake Troubleshooting.** Figure A-11 provides a static check of the Option 001 acceptor handshake circuit. However, it is possible to have a condition where a faulty circuit would not be detected by performing these checks. If a timing problem is suspected, the acceptor handshake circuit must be checked dynamically. A dynamic test can be made by continuously programming the 6002A-001 to "listen" and observing the handshake signals on an oscilloscope. The handshake cycle timing relationships are shown in Figure A-6.

### A-101 Removal and Replacement

**A-102** The Option 001 circuitry is located in the rear (upper section) of the 6002A chassis (see Figure A-1). Component location diagrams and schematics for the Option 001 A100, A200, and A300 printed circuit boards are provided in Figures A-12 through A-15 at the end of this appendix, Option 001 replaceable parts are listed in Table A-4. When replacing parts, perform the following steps:

- a. Turn off power.
- b. Remove rear screw in the handle assembly on top of unit and slide cover (one piece cover for top and sides) to the rear and remove.
- c. The A200 board, component side up, is mounted on plastic standoffs directly above the A300 board (component side down). Lift the A200 board up and away from the A300 board. With the A200 board moved aside, the test points on the back (wiring side) of the A300 board are accessible (see Figure A-14B).

### CAUTION

*If the circuits are being disassembled for troubleshooting purposes, ensure that the components and tracks on the A200 board are not touching the metal chassis. Also ensure that the AC input terminals on the A300 board are not touched or grounded.*

- d. To remove the A300 board, remove 2 screws, slide board forward out of the PCB slides, and lift board up and away from the chassis.
- e. The A100 board, address switch mode switches, and HP-IB connector are removed as follows:
  1. Remove 1 screw securing A100 board to chassis.
  2. Remove 1 screw and 2 nuts securing the HP-IB connector and the switches to the supply's rear panel.
  - f. Remove two screws securing Option 001 support bracket to chassis.
  - g. Disconnect A2P1 and remove Option 001 circuits (A100, A200, A300 boards) and support bracket from the 6002A chassis.

### NOTE

*If the supply is operated with the Option 001 circuitry removed, jumpers A2W1, A2W2, A2W3, A2W4 must be installed on the A2 Interconnect Board as described in paragraph A-54.*

### A-103 Adjustments

**A-104** The option 001 analog circuits are factory adjusted for constant voltage (CV) operation. The CV adjustments, described in paragraphs A-106 and A-107, may be required after performing the checkout procedures, troubleshooting, or repair and replacement. If constant current (CC) operation is desired, the circuits must be readjusted as described in paragraph A-108.

### A-105 Test Setup.

- a. Remove top cover from power supply (see paragraph A-102) to gain access to the potentiometers on the A300 board. Potentiometer access holes are located and labeled on upper right side in the rear of the power supply chassis.
- b. Connect oscilloscope to the +S and -S terminals on the rear of the supply. Set 0V reference line across center of scope. Set SWEEP to 1msec/div.
- c. Check that the address switches on rear of supply are set to "%".
- d. Connect power supply to an HP-IB controller.

CORRECT 6002A-001 AND CONTROLLER TO HP-1B. TURN ON 6002A AND CHECK THE OPTION 001 SUPPLY VOLTAGES ON THE A300 BOARD. CONNECT METER LEADS ON A300 BC AS INDICATED.

NOTE  
TEST POINTS ON REAR (WIRING) SIDE OF A300 BOARD ARE SHOWN ON FIG. A-14B

METER COMMON	METER POSITIVE	NORMAL READING
∇	+5	5.0 ± 0.25 VDC
∇	+15	15.0 ± 0.75 VDC
∇	-15	15.0 ± 0.75 VDC
∇	V <sub>REF</sub>	5.0 ± 0.25 VDC

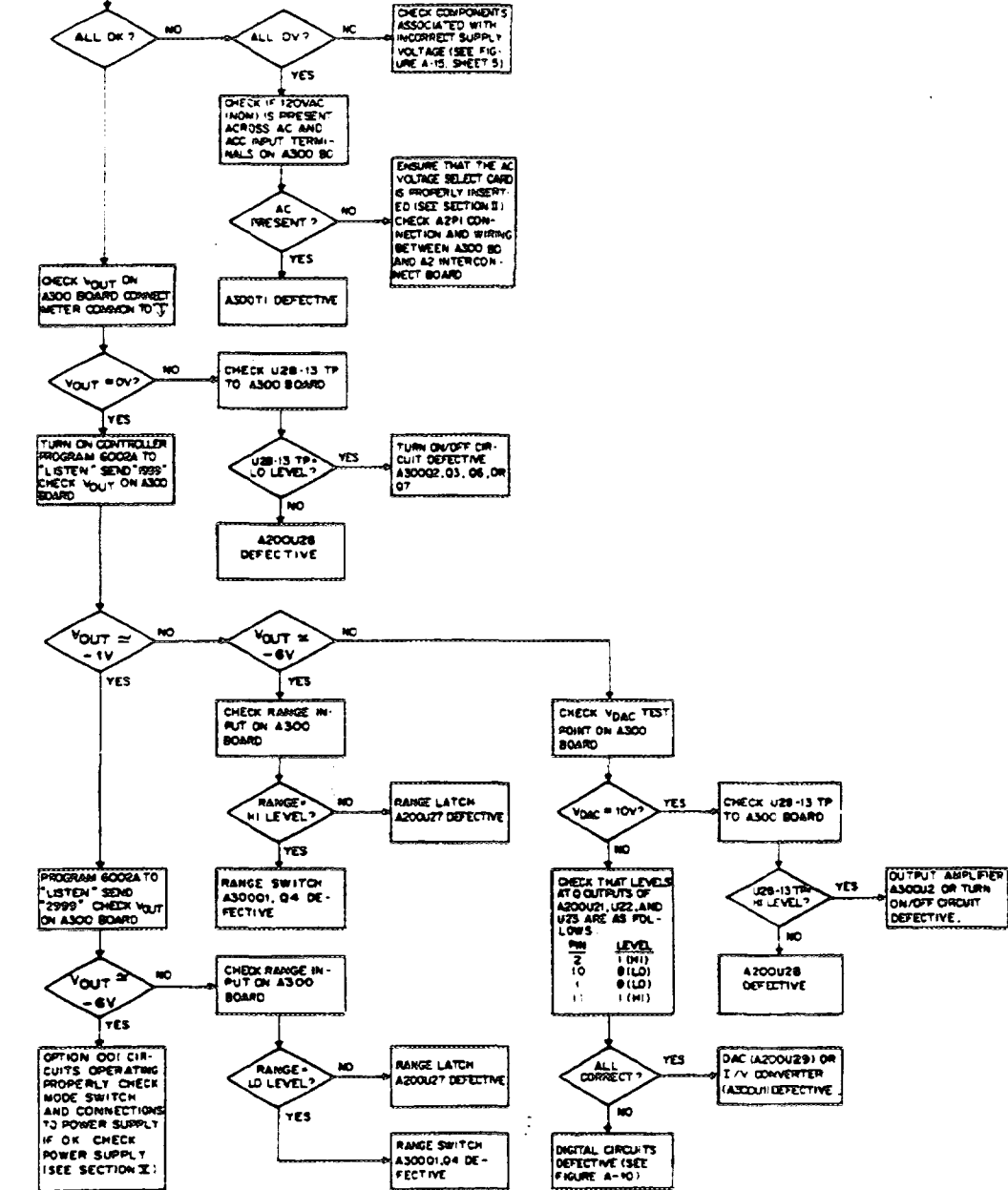

Figure A-9. Overall Troubleshooting Procedures, Flow Chart

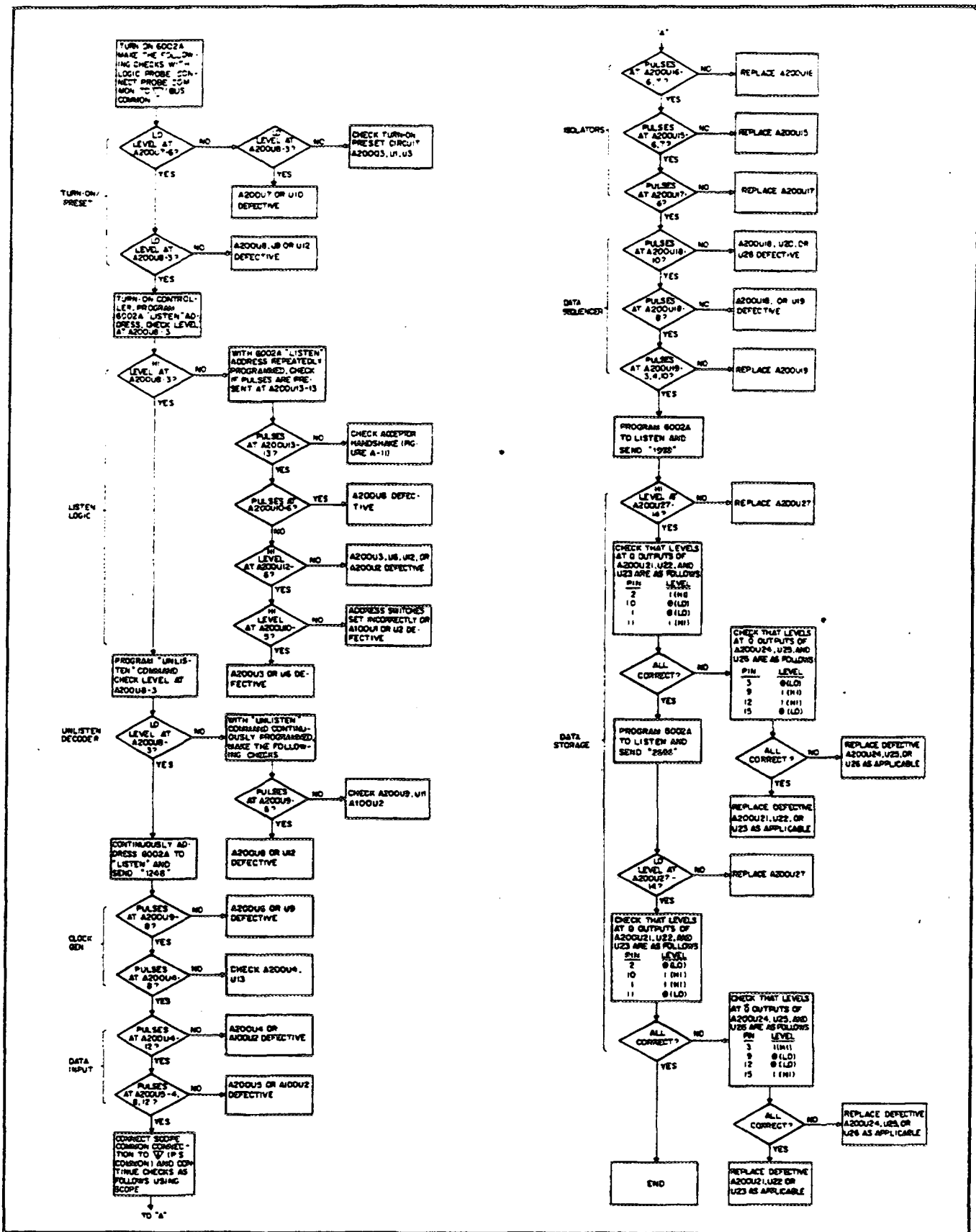

Figure A-10. Digital Circuits Troubleshooting, Flow Chart

- e. Turn on controller and power supply and allow a 30-minute warm-up.

### WARNING

Before making any of the following adjustments, ensure that one of the power supply's output terminals (+ or -) is grounded. Failure to do so may result in a shock hazard and/or damage to the unit.

**A-106 CV Zero Output Adjustment.** To adjust the zero voltage programming accuracy for the high and low ranges, proceed as follows:

- Set mode switches on rear of supply to CV.
- Alternately program data words 2000 (zero high range) and 1000 (zero low range) with a 50msec (approx.) delay between data words.
- Adjust the ZERO ADJ. potentiometer (A300R19) and the ZERO BALANCE ADJ. potentiometer (A300R4) for a straight line at zero as indicated on the scope. Potentiometers are adjusted simultaneously to obtain the desired scope indication.

**A-107 CV High and Low Range Full Scale Adjustments.** Use the same test setup as above, except, remove oscilloscope and connect a DVM between the +S and -S rear terminals.

- Program data word 2999 and adjust HIGH RANGE FULL SCALE potentiometer A300R7 for a reading of 49.950V on DVM.
- Program data word 1999 and adjust LOW RANGE FULL SCALE potentiometer A300R9 for a reading of 9.990V on DVM.
- Recheck the low and high ranges and the zero output adjustment. If necessary, repeat adjustments given in paragraph A-106 and steps a and b above.

**A-108 CC Adjustments.**

- Turn off supply and set mode switches to CC.
- Turn VOLTAGE control on front panel fully clockwise.
- Use the constant current test setup (Figure 5-7) provided in Section V, except set  $R_{L1}$  and  $R_{L2}$  to approximately  $3.5\Omega$  each and use a  $0.01\Omega$  resistor for current sampling resistor  $R_S$ .
- Connect power supply to an HP-1B controller and turn both instruments on. Allow a 30-minute warm-up.
- Adjust CC zero output by connecting an oscilloscope to +S and -S terminals and repeating steps b and c of paragraph A-106.
- Adjust CC high range full scale output by programming data word 2999 and adjusting A300R7 for a reading of .0999V on DVM (connected across  $R_S$  as shown in Figure 5-7).
- Adjust CC low range full scale output by pro-

gramming data word 1999 and adjusting A300R9 for a reading of .01998V on DVM (connected across  $R_S$ ).

- Recheck adjustments. If necessary repeat steps e through g above.

### A-109 DIAGRAMS

**A-110** Figures A-12 through A-14 illustrate the physical location and reference designations for the parts on Option 001 printed circuit boards A100, A200, and A300. The circuit boards are functionally separated and included on schematic diagram, Figure A-15 (sheets 1 through 5). The functional circuits and test points shown on the schematic coincide with those on the component location diagrams and troubleshooting flow charts (Figures A-9 through A-11).

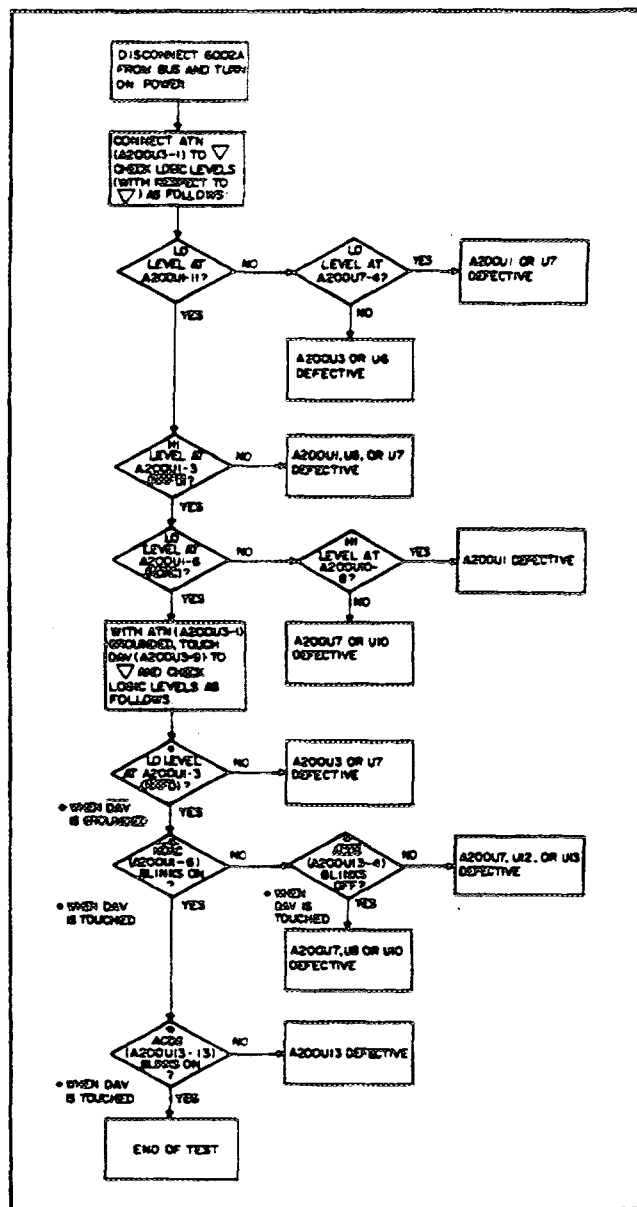

Figure A-11. Acceptor Handshake Circuits Troubleshooting Flow Chart

Table A-4. Option 001 Replaceable Parts

REF. DESIG.	DESCRIPTION	TQ.	MFR. PART NO.	MFR. CODE	HP PART NO.	RS
<b>A100</b>	<b>Input Board Assembly (See Note 1)</b>	1				1
C1	fxd, elect. 2.2 $\mu$ F, 20%, 20V	1	150D225X0020A2	56289	0180-0155	1
C2	fxd, cer. 0.02 $\mu$ F, 20%, 100WVdc	1	C023B101H203MS27	56289	0160-0818	1
J1	HP-1B connector, 24-pin	1			1251-3283	
S1	Address switch	1		28480	3101-1973	
S2, S3	Mode pushbutton switches (2-station)	1		28480	3101-1908	1
U1	Digital Comparator, IC	1	93L24DC	07263	1820-0904	1
U2	Hex Schmitt Trig. Inverter, IC	1	SN74LS14N	01295	1820-1416	1
Z1, Z2	Resistor Network, 3k/6.2k, 5%, .02W	2	216C	56289	1810-0136	1
Z3	Resistor Network, 4.7k, 5%, 0.15W	1	200C-1858-CRR	56289	1810-0125	1
<b>A200</b>	<b>Digital Board Assembly (See Note 1)</b>	1				
C1	fxd, cer. 1000pF, 1kV	1	C067B102E102ZS26	56289	0150-0050	1
C2	fxd, mica. 500pF, 1%, 300V	1	DM15F501F0300W1C	72136	0140-0234	1
C3, C4	fxd, mica. 91pF, 1%, 300V	2		28480	0160-0335	1
C5	fxd, cer. 470pF, 10%, 1000WVdc	1	DD-471	71590	0160-2496	1
C6	fxd, elect. 22 $\mu$ F, 10%, 15V	1	150D226X9015B2	56289	0180-0228	1
C7-C13	fxd, cer. 0.1 $\mu$ F, 50V	10	5C5081-CML	56289	0150-0121	2
C14	fxd, elect. 10 $\mu$ F, 10%, 20V	3	150D106X902B2	56289	0180-0374	1
C15	fxd, cer. 0.1 $\mu$ F, 50V	1	5C5081-CML	56289	0150-0121	1
C16, C17	fxd, elect. 10 $\mu$ F, 10%, 20V		150D106X9020B2	56289	0180-0374	
C18	fxd, elect. 1 $\mu$ F, 10%, 35V	1	150D105X9035A2	56289	0180-0291	1
C19	Not assigned					
C20-C22	fxd, cer. 0.1 $\mu$ F, 50V		5C5081-CML	56289	0150-0121	
CR1-CR3	Not assigned					
CR4	Diode, Si. 200mA, 75V	1	1N4148	28480	1901-0050	1
Q1, Q2	Not assigned					
Q3	SS NPN Si.	1	2N4141	28480	1854-0071	1
R1	fxd, film 383 1%, 1/8W	2	C4-1/8-TO-383R-F	24546	0698-3446	1
R2	fxd, film 5.11k, 1%, 1/8W	2	C4-1/8-TO-5111-F	24546	0757-0438	1
R3-R7	Not assigned					
R8	fxd, film 42.2k, 1%, 1/8W	1	C4-1/8-TO-4222-F	24546	0698-3450	1
R9	fxd, film 383, 1%, 1/8W		C4-1/8-TO-383R-F	24526	0698-3446	
R10-R15	fxd, film 162 1%, 1/8W	6	C4-1/8-TO-162R-F	24546	0757-0405	1
R16	fxd, film 47.5k, 1%, 1/8W	1	C4-1/8-TO-4752-F	24546	0757-0457	1
R17-R22	fxd, film 4.12k, 1%, 1/8W	6	C4-1/8-TO-4121-F	24546	0698-3493	1
R23	fxd, film 16.2k, 1%, 1/8W	1	C4-1/8-TO-1622-F	24546	0757-0447	1
R24	fxd, film 2.37k, 1%, 1/8W	1	C4-1/8-TO-2371-F	24546	0698-3150	1
R25	fxd, film 10 1%, 1/8W	1	C4-1/8-TO-10R0-F	24546	0757-0346	1
R26-30	Not assigned					
R31	fxd, film 20k, 1%, 1/8W	1	C4-1/8-TO-2002-F	24546	0757-0449	1
R32	fxd, film 5.11k, 1%, 1/8W		C4-1/8-TO-5111-F	24546	0757-0438	
R33	fxd, film 1k, 1%, 1/8W	1	C4-1/8-TO-1001-F	24546	0757-0280	1
U1	Quad 2-Input Positive-NAND Buffer, Open Coll., IC	1	SN7438N	01295	1820-0621	
U2	Not assigned					
U3	Hex Schmitt Trig. Inverter, IC	1	SN74LS14N	01295	1820-1416	1
U4-U6	Hex Inverter, IC	3	SN74LS04N	01295	1820-1199	3
U7-U9	Quad 2-Input Positive-NAND Gate, IC	3	SN74LS00N	01295	1820-1197	3

Note 1: This assembly is designed for component level repair. Replacement assemblies cannot be supplied.

Table A-4. Option 001 Replaceable Parts

REF. DESIG.	DESCRIPTION	TQ	MFR. PART NO.	MFR. CODE	HP PART NO.	RS
A200U10	Dual 4-Input NAND Gate, IC	1	SN74LS20N	01295	1820-1204	1
U11	8-Input Positive-NAND Gate, IC	1	SN74LS30N	01295	1820-1207	1
U12	Triple 3-Input Positive-NOR Gates	1	SN74LS27N	01295	1820-1206	1
U13	Dual Monostable Multivibrator with Schmitt Trig. Inputs, IC	1	SN74LS221N	01295	1820-1437	1
U14	Not assigned					
U15-U17	Dual High Speed Optically Coupled Isolators	3		28480	5082-5495	3
U18	COS/MOS Hex Inverter, IC	1	CD4069BY	02735	1820-1404	1
U19	COS/MOS Quad 2-Input AND Gate, IC	1	CD4081BY	02735	1820-1486	1
U20	COS/MOS Triple 3-Input OR Gate, IC	1	CD4075BY	02735	1820-1405	1
U21-U26	COS/MOS Quad Clocked "D" Latch, IC	6	CD4042AY	02735	1820-1540	6
U27	COS/MOS Dual J-K F/F, IC	1	CD4027AE	02735	1820-0938	1
U28	COS/MOS Dual 4-Stage Static Shift Reg., IC	1	CD4015AE	02735	1820-0976	1
U29	12-Bit D/A Converter, IC	1		28480	1820-1856	1
<b>A300</b>	<b>Analog Board Assembly (See Note 1)</b>	<b>1</b>				
C1	fxd., mica 30pF 5% 500V	1	DM15E300J0500WV1CR	72136	0140-0203	1
C2, C3	fxd., cer. 220pF 5% 500V	2	2DDT60L221JAB	71590	0150-0111	1
C4, C5	fxd., elect. 180μF 50V	2	672D047	56289	0180-0634	1
C6, C7	fxd., cer. 0.1μF, 50V	3	5C5081-CML	56289	0150-0121	1
C8, C9	fxd., mica 1500pF 5% 300WVdc	2		28480	0160-3068	1
C10, C11	fxd., elect. 10μF 10% 20V	2	150D106X9020B2	56289	0180-0374	1
C12	fxd., elect. 2000μF, 20V	1		28480	0180-2685	1
C13	fxd., cer. 0.1μF 50V	1	5C5081-CML	56289	0150-0121	1
C14	fxd., elect. 22μF 10% 15V	1	150D226X9015B2	56289	0180-0228	1
C15	fxd., elect. 1μF 10% 35V	1	150D105X9035A2	56289	0180-0291	1
CR1-CR8	Diode, power rectifier	8		28480	1901-0327	8
CR9	Diode, Si. 200mA 75V	1		28480	1901-0050	1
Q1, Q2	J-FET	2	2N4392	04713	1855-0386	2
Q3	J-FET N-Chan Si.	1		28480	1855-0091	1
Q4, Q5	SS NPN Si.	3		28480	1854-0071	
Q6	SS PNP Si.	1		28480	1853-0099	1
Q7	SS NPN Si.	1		28480	1854-0071	1
R1	fxd., film 61.9k 1% 1/8W	1	C4-1/8-TO-6192-F	24546	0757-0460	1
R2	fxd., film 46.4k 1% 1/8W	2	C4-1/8-TO-4642-F	24546	0698-3162	1
R3	fxd., film 51.1k 1% 1/8W	4	C4-1/8-TO-5112-F	24546	0757-0548	1
R4	var. cermet. 20k 10%	3	3006P-1-203	32997	2100-3307	1
R5	fxd., film 3.57k 1% 1/8W	1	C4-1/8-TO-357R-F	24546	0698-3496	
R6	fxd., film 17.4k 1% 1/8W	1	MF4C-1/8-T9-1742-F	19701	0698-7969	1
R7	var., cermet. 5k 10%	1	3006P-1-502	32997	2100-3308	1
R8	fxd., film 70k 1% 1/8W	1	MF4C-1	19701	0698-6388	1
R9	var., cermet. 20k 10%		3006P-1-203	32997	2100-3307	
R10	fxd., film 12.5k 1% 1/8W	1	C4-1/8-TO-1252-F	24546	0698-6276	1
R11	fxd., film 243 1% 1/8W	1	C4-1/8-TO-243R-F	24546	0757-0408	1
R12	fxd., film 7.5k 1% 1/8W	1	C4-1/8-TO-7501-F	24546	0757-0453	1
R13	fxd., film 2.15k 1% 1/8W	1	C4-1/8-TO-2151-F	24546	0757-0472	1
R14	fxd., film 68.1k 1% 1/8W	1	C4-1/8-TO-6821-F	24546	0757-0461	1
R15	Not assigned					



Table A-4. Option 001 Replaceable Parts

REF. DESIG.	DESCRIPTION	TQ	MFR. PART NO.	MFR. CODE	HP PART NO.	RS
A300R16	fxd., film 90.9k 1% 1/8W	1	C4-1/8-TO-9092-F	24546	0757-0464	1
R17	fxd., film 51.1k 1% 1/8W		C4-1/8-TO-5112-F	24546	0757-0458	
R18	fxd., film 46.4k 1% 1/8W		C4-1/8-TO-4642-F	24546	0698-3162	
R19	var., cermet. 20k 10%		3006P-1-203	32997	2100-3307	
R20	fxd., film 11.3k 1% 1/8W	1	C4-1/8-TO-1132-F	24546	0698-4121	1
R21	fxd., film 9.31k 1% 1/8W	1	C4-1/8-TO-9311-F	24546	0698-0064	1
R22	fxd., film 5.62k 1% 1/8W	1	C4-1/8-TO-5621-F	24546	0757-0200	1
R23	fxd., film 21.5k 1% 1/8W	1	C4-1/8-TO-2152-F	24546	0757-0199	1
R24	fxd., film 51.1k 1% 1/8W		C4-1/8-TO-5112-F	24546	0757-0458	
R25	fxd., film 121k 1% 1/8W	3	C4-1/8-TO-1213-F	24546	0757-0467	1
R26	fxd., film 34.8k 1% 1/8W	1	C4-1/8-TO-3482-F	24546	0757-0123	1
R27	fxd., film 118k 1% 1/8W	1	C4-1/8-TO-1183-F	24546	0698-3265	1
R28, R29	fxd., film 121k 1% 1/8W		C4-1/8-TO-1213-F	24546	0757-0467	
R30	fxd., film 51.1k, 1%, 1/8W		C4-1/8-TO-2152-F	24546	0757-0458	
T1	Power Transformer	1		28480	5080-1862	1
U1	Operational amplifier, IC	1	LM301AH	27014	1820-0223	1
U2	Operational amplifier, IC	1	LM308	27014	1826-0172	
U3	Dual ±15V Reg., IC	1	MC1468	04713	1826-0140	1
U4	5V Regulator, IC	1	MC7805C	04713	1826-0144	1
VR1	Diode, zener 14.7V 5%	1		28480	1902-0184	1
VR2	Diode, zener 12.4V 5%	1		28480	1902-3185	1
	<b>Mechanical</b>					
	IC Socket, 14-pin (Address Switch)	1		28480	1200-0485	
	Pushbutton knobs (Mode switches)	2		28480	0370-2486	
	Connector 21-pin (A2P1)	1		28480	1251-4054	
	Standoff, Mounting (A200 board)	2		28480	0380-0644	
	PC board guide (A300 board)	2		28480	0403-0164	
	Support bracket	1		28480	06002-00010	

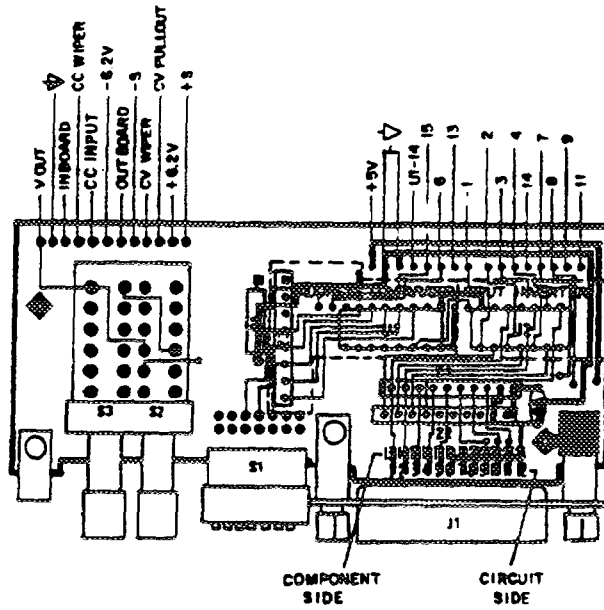

Figure A-12 A100 Input Board, Component Locations

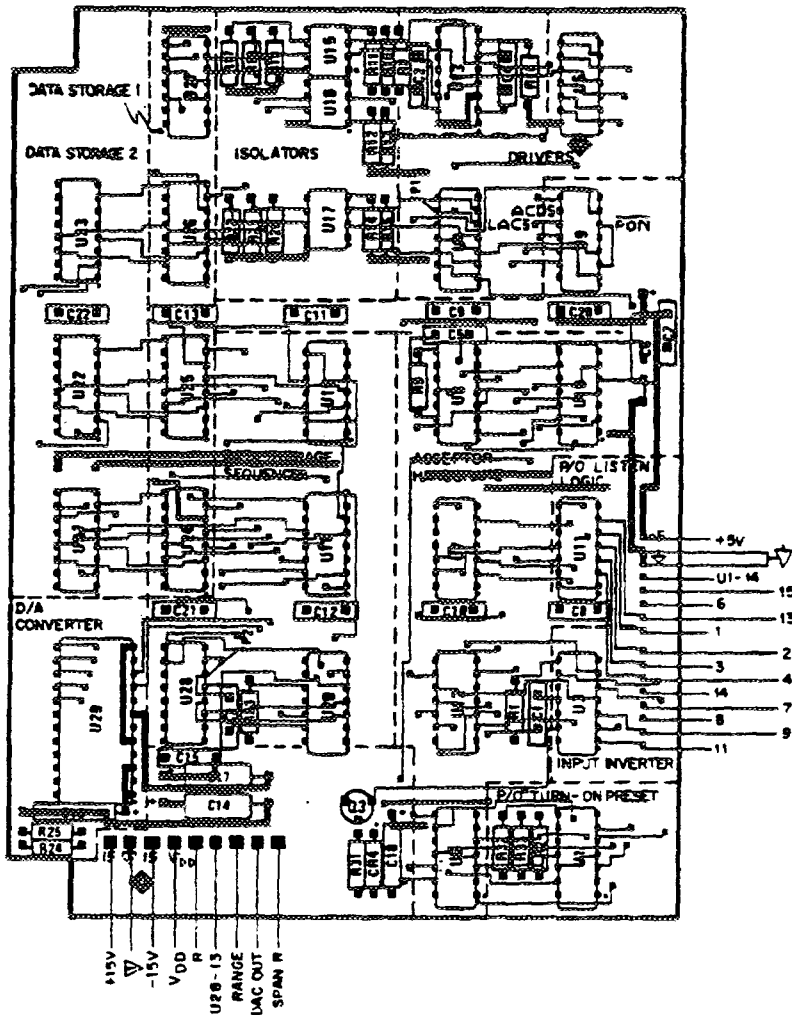
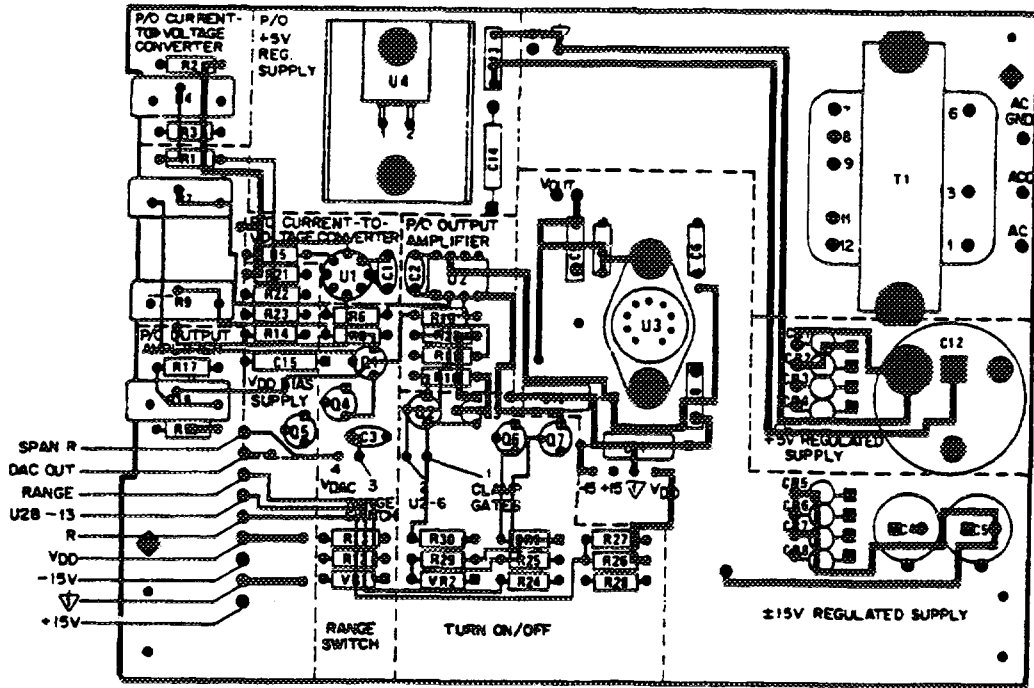
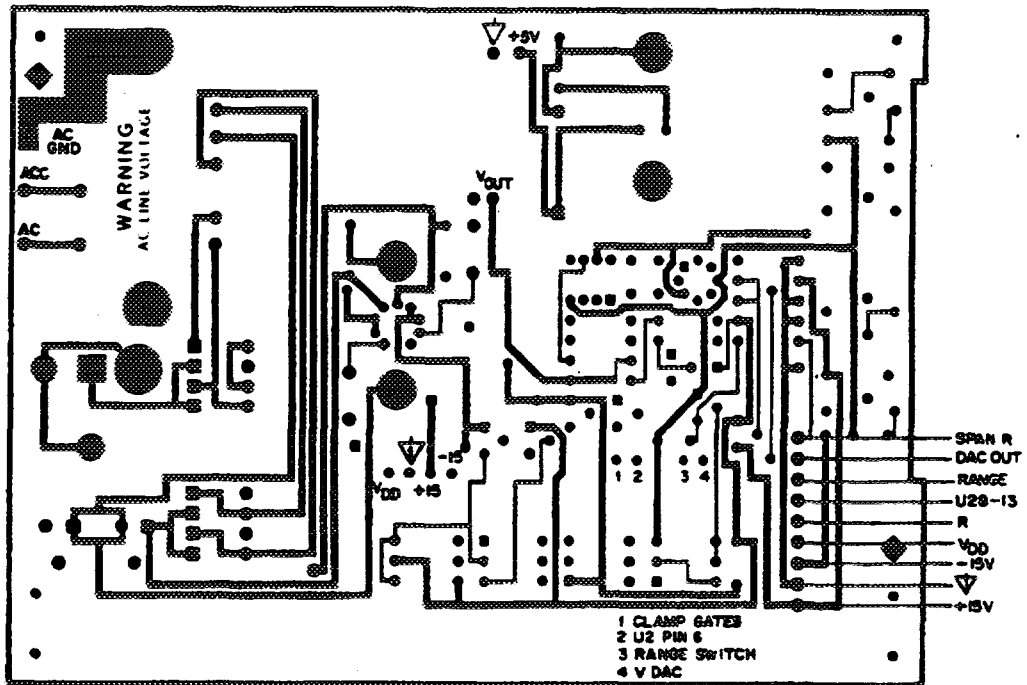

Figure A-13. A200 Digital Board, Component Locations



A. A300 Board Component Side



B. A300 Board Wiring Side

Figure A-14. A300 Analog Board, Component Locations and Test Points

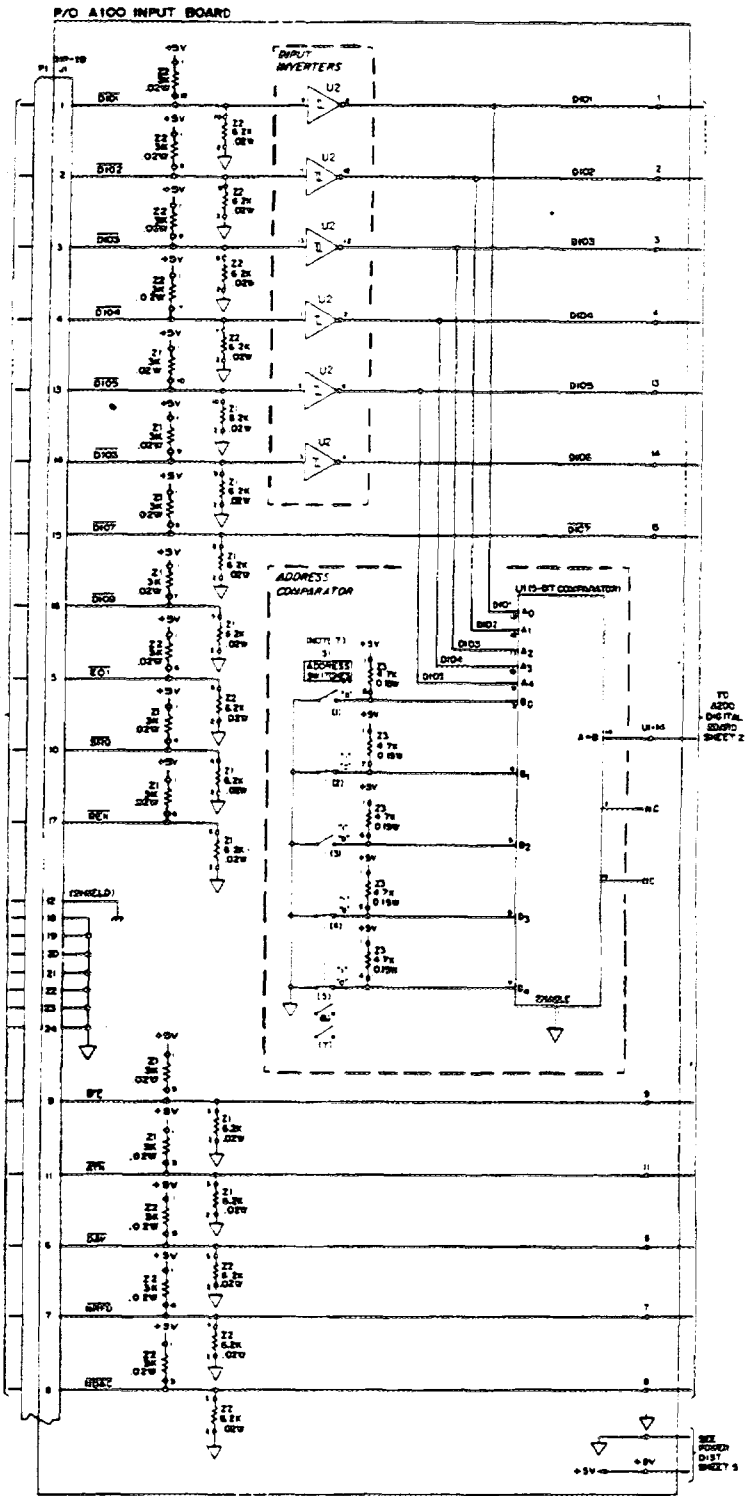

- 1 ALL RESISTORS ARE IN OHMS, V/O, ± 1%, UNLESS OTHERWISE INDICATED
- 2 ALL CAPACITORS ARE IN MICROFARADS, UNLESS OTHERWISE INDICATED
- 3 PIN LOCATIONS FOR THE 14-PIN, 16-PIN, AND 20-PIN IC'S ARE AS FOLLOWS

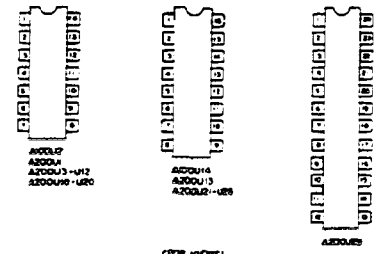

- 4 THE LOCATIONS FOR RESISTOR NETWORKS A0001-23, PHOTO-ISOLATORS A0003-U7, OPERATION AMPLIFIERS A0004 AND U2, 2.0V REGULATOR A0003, AND +5V REGULATOR A0004 ARE AS FOLLOWS:

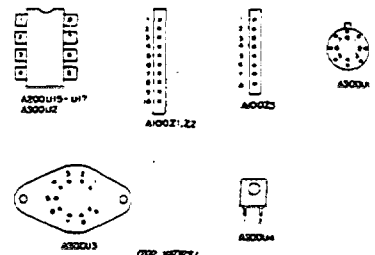

- 5 THE SQUARE PLATED PINS ON THE P.C. BOARD INDICATE ONE OF THE FOLLOWING:

- A PIN 1 OF ANY IC OR TRANSFORMER
- B POSITIVE END OF A POLARIZED CAPACITOR
- C CATHODE OF A DIODE OR EMITTER OF A TRANSISTOR

- 6 THE S2 AND S3 MODE SWITCHES (PUSH-IN, PUSH-OUT) ON THE REAR PANEL CONTROL OPERATION OF THE 600A POWER SUPPLY AS FOLLOWS:

SWITCH POSITION	MODE OF OPERATION
BOTH OUT	LOCAL CONTROL, THE FRONT PANEL VOLTAGE AND CURRENT POTENTIOMETERS CONTROL CV/CC OPERATION
S2 (CV) IN, S3 (CC) OUT	CV CONTROL VIA HP-18, CC CONTROL VIA FRONT PANEL CURRENT POTENTIOMETER
S2 (CV) OUT, S3 (CC) IN	CC CONTROL VIA HP-18, CV CONTROL VIA FRONT PANEL VOLTAGE POTENTIOMETER
BOTH IN	OUTPUT OF SUPPLY IS HELD NEAR ZERO AND CONTROL FROM HP-18 OR FROM FRONT PANEL CONTROLS

- 7 THE LISTEN ADDRESS FOR THE 600A IS SPECIFIED BY THE PINE ADDRESS SWITCHES ON THE REAR PANEL. THE SUGGESTED LISTEN ADDRESS OF "0" IS SHOWN SELECTED, HOWEVER, ANY ONE OF 31 LISTEN ADDRESSES CAN BE SELECTED (SEE PARAGRAPH A-12)

Figure A-15.(Sheet 1). Option 001, Input Board A100, Schematic Diagram



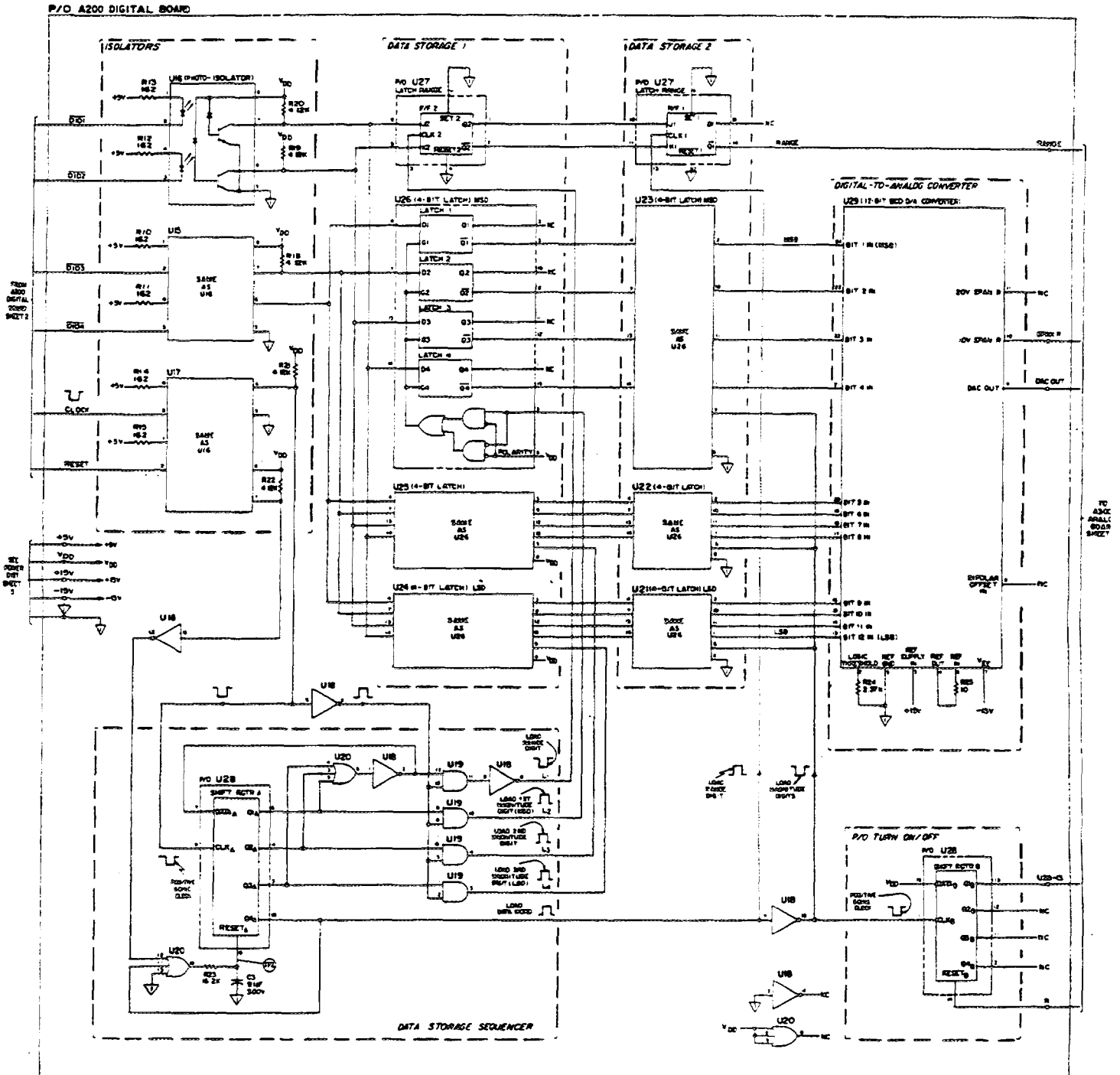

Figure A-15 (Sheet 3). Option 001, P/O Digital Board A200, Schematic Diagram

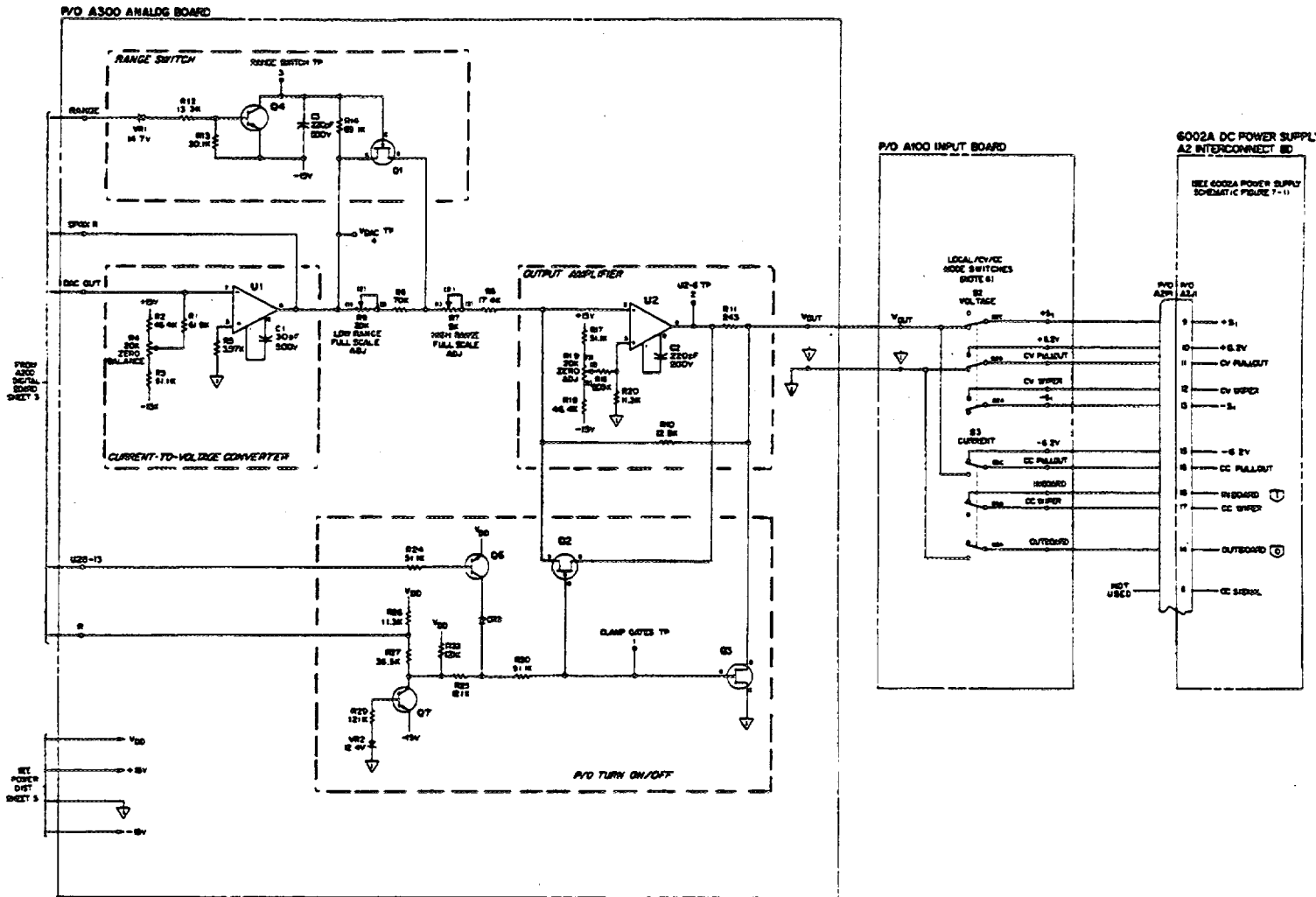

Figure A-15 (Sheet 4). Option 001, Analog Board A300 and Mode Switches, Schematic Diagram

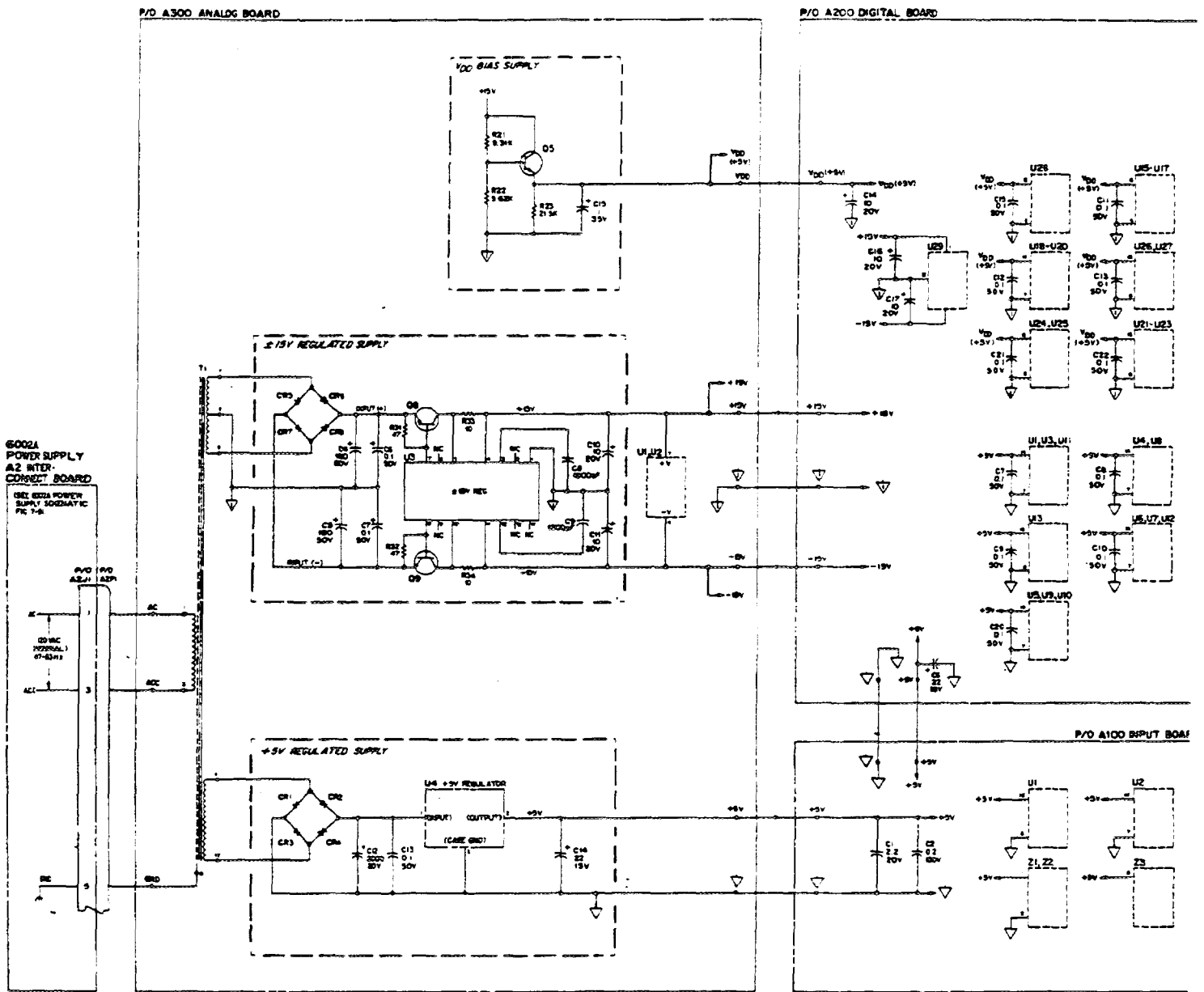

Figure A-15 (Sheet 5). Option 001, Power Distribution